

# Energy Efficient Geared Motors

## Electric Monorail Systems

Catalogue Edition 07/23 EN

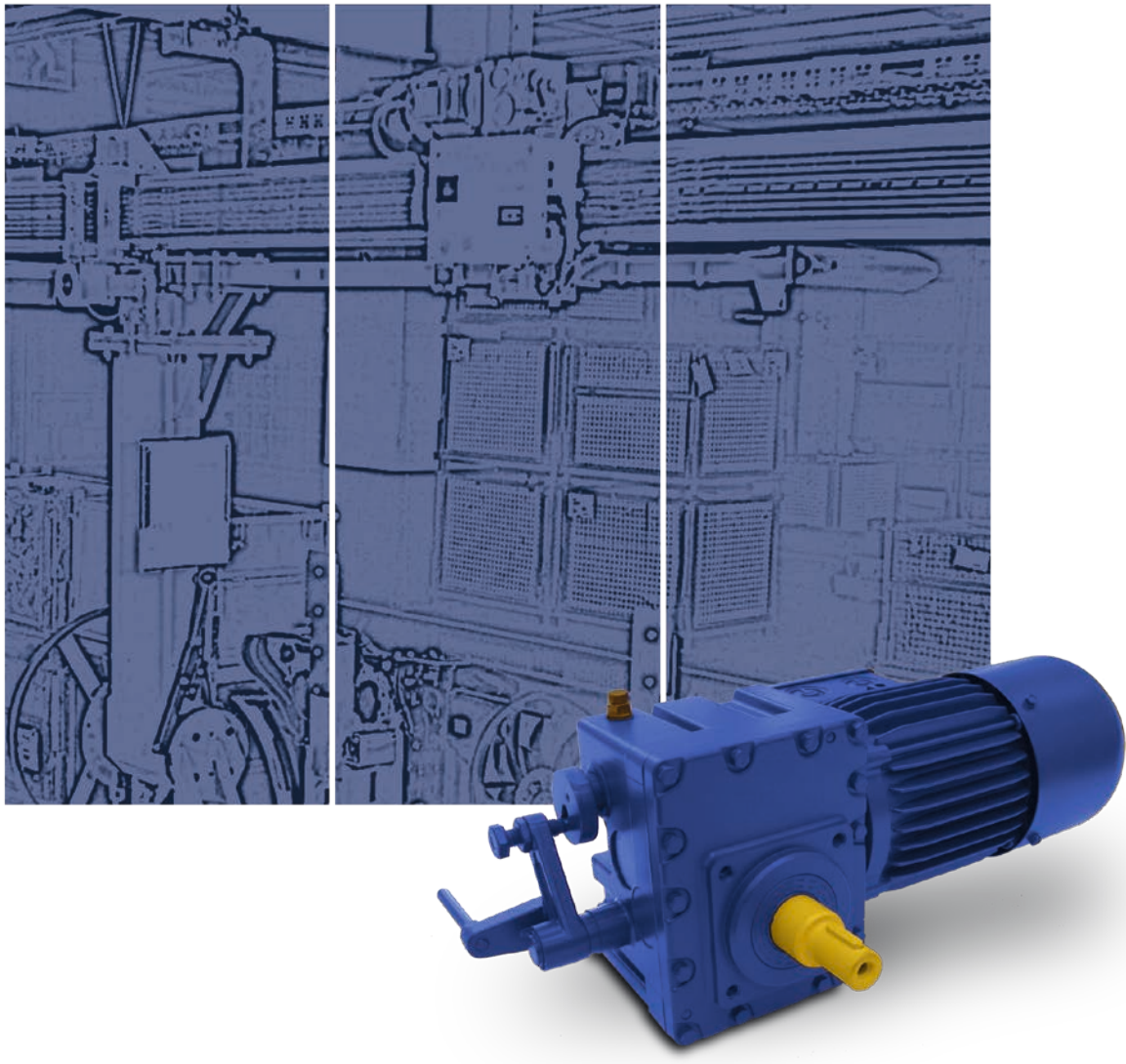

 **BAUER GEAR MOTOR**™  
A REGAL REXNORD BRAND

# Type Designations

## BM 10 - 7 1 V / D.. 09L A 4 - TF - ST - G - SL- K / ES 010 A 9 HN / C2

**B M 10 Z X - 7 1 V**

- V = Flange A or C front
- H = Flange A or C rear
- UO = Foot below and above
- 1 = Solid shaft, front
- 2 = Solid shaft, rear
- 3 = Solid shaft, front and rear
- 7 = Solid shaft front, flush with standard flange only BM30-BM40
- 0 = Gearbox housing, no machined surfaces
- 6 = Gear housing, foot-threaded bores
- 7 = Gear housing, C - flange
- = Separates gearbox type from gearbox version
- X = Reinforced bearing for higher wheel loads
- Z = Gearbox with pre-stage
- = Gear size (09,10, 20, 30, 40)
- B • = Gear type (BM)

**D .. 09 L A 4 - TF - S**

- S = Rectifier
- TF = Motor monitoring
- 4 = No. of pole for motor
- LA = Motor core length and design
- 09 = Motor size
- .. = SE Three-phase motor with increased efficiency according to IE1
- .. = HE Three-phase motor with increased efficiency according to IE2
- .. = PE Three-phase motor with increased efficiency according to IE3
- D = Three-phase motor
- S = Permanent magnet excited synchronous motor with efficiency according to IE4

**ES 010 A 9 HN**

- HA = Hand release (lockable)
- HN = Hand release (none lockable)
- 9 = Code for setting torque
- A = Design
- 010 = Brake size
- ES = Single disk brakes - HOLDING BRAKE
- ZS = Double disk brakes - HOLDING BRAKE
- ESX = Single disk brakes - WORKING BRAKE
- ZSX = Double disk brakes - WORKING BRAKE

**BM .. - 07 V / .. / S ..**

- 01 = A-flange and solid shaft pulled forward on gearbox part side V (BM30, BM40)
- 02 = A-flange and solid shaft „far“ forward on gearbox side V (BM30, BM40)
- V = Flange A
- 7 = Vollwellenfront, nur mit Standardflansch bündig BM30-40
- 0 = Gearbox housing, no machined surfaces
- = Separates gearbox type from gearbox version
- .. = Gearbox size (09, 10, 20, 30, 40)
- BM = Gear type (BM)

### Table of contents

<b>1 General</b>	<b>13</b>
<b>Advantages of Bauer-Geared Motors</b>	<b>15</b>
Bauer-electric overhead conveyors systems	15
Bauer Gearboxes	15
Bauer Motors	15
Bauer Brakes	15
<b>2 Product Description</b>	<b>17</b>
<b>Selection of geared motors</b>	<b>19</b>
Installed positions of geared motors	19
Notes on safety	19
Guards for rotating parts	19
Touch protection	19
Operating noise	19
Painting and corrosion protection	19
<b>Description of BM geared motors</b>	<b>20</b>
Five unit sizes to handle every load	20
<b>3 Type Designations</b>	<b>21</b>
<b>Significance of type designation</b>	<b>23</b>
Significance of type designation	23
<b>Electric overhead conveyors series BM</b>	<b>24</b>
<b>Versions and options</b>	<b>25</b>
Gear unit designs	25
Type designation and components of the BM-series geared motors	25
<b>Motor</b>	<b>26</b>
Three-phase motor	26
Motor protection	26
Brake rectifier in motor terminal box	26
Plug connector	26
Heavy-duty fan	26
Protective cover	26
<b>Motor Mounted Components</b>	<b>27</b>
Brake	27
Reverse rotation block	27
Encoders	27
Second shaft end	27
Forced ventilation	27
Overall design	27
<b>4 Gear Motor Selection</b>	<b>29</b>
<b>Project planning advice</b>	<b>31</b>
Procedure for selecting BM-series geared motors	31
Carriage design	34
<b>Selection of geared motors</b>	<b>36</b>
<b>5 Gearboxes &amp; Lubrication</b>	<b>39</b>
<b>Geared motor selection</b>	<b>41</b>
Standard fitting position of BM geared motors	41
Position of the terminal box and the cable glands	41
<b>Lubricants</b>	<b>42</b>
Lubricants	42
Lubricant quantities	43
Lubricant quantities, BM-series gears	44
Lubricant quantity the primary stage (Z) for installation type H1	45
Gear ventilation	45
<b>Threaded plugs</b>	<b>46</b>
Position of threaded plugs	
- BM-series gears	46
- pre-stage gears (Z)	47
- in the System Cover Design with Standard Geared Motor	48

# Energy Efficient Geared Motors

## Table of contents

<b>6 Selection tables ASM-IE1</b>	<b>49</b>
Selection table asynchronous motors ASM IE1 .....	51
<b>7 Selection tables ASM-IE2</b>	<b>63</b>
Selection table asynchronous motors ASM IE2 .....	65
<b>8 Selection tables ASM IE2</b>	<b>75</b>
Selection table asynchronous motors ASM IE2 .....	77
<b>9 Selection tables PMSM IE4</b>	<b>89</b>
Selection table asynchronous motors PMSM IE4 1500 <sup>1</sup> / <sub>min</sub> .....	91
Selection table asynchronous motors PMSM IE4 3000 <sup>1</sup> / <sub>min</sub> .....	101
<b>10 Electric overhead conveyors series BM - Dimension</b>	<b>111</b>
<b>Dimension - Standard</b> .....	<b>113</b>
BM09 .....	113
BM10-BM10X .....	114
BM20-BM20Z .....	116
BM30-BM30Z .....	118
BM40-BM40Z .....	120
<b>Additional Dimension Sheet</b> .....	<b>122</b>
Standard terminal box .....	122
Plug-connector terminal box .....	123
Standard brakes .....	124
“Heavy-Duty“- brake .....	125
Motors with back stop .....	126
Motors with second shaft end .....	127
Motors with brake and second shaft end .....	128
Motors with “heavy duty“ brake and second shaft end .....	129
Motors with protective hood .....	130
Motors with independent fan .....	131
Motors with brake and independent fan .....	132
Motors with encoder and built-on independent fan .....	133
Motors with brake and encoder with built-on independent fan .....	134
Motors with standard encoder .....	135
Motors with “heavy duty“ encoder .....	136
Motors with brake and encoder .....	137
Motors with “heavy duty“ brake and encoder .....	138
Motors in IEC design .....	139
<b>11 Motors - ASM</b>	<b>141</b>
<b>General</b> .....	<b>143</b>
ErP Directive 2009/125/EC .....	143
Regulation (EU) 2019/1781 .....	144
Torques .....	146
Line voltages .....	146
Line frequencies .....	147
Rating plate .....	147
Terminal box .....	147
Motor connections .....	148
Terminal connections for single speed motors without motor protection .....	149
Terminal connections for single speed motors with motor protection .....	150
Terminal connections for pole changing motors in Dahlander connection ( $\Delta/YY$ or $Y/YY$ ) .....	151
Terminal connections for pole changing motors with two separate windings ( $Y/Y$ or $\Delta/\Delta$ ) .....	152
Plug-and-socket connection .....	153
Motor protection .....	154
Thermistors (PTC) .....	154
Thermostatic protection .....	155
KTY sensors .....	156
PT100 sensors .....	157
Insulation .....	158
IP – Protection classes .....	158
Degrees of protection provided by enclosures for electrical equipment .....	158
Speed of output shaft .....	159



<b>Duty types as defined by EN 60034 .....</b>	<b>160</b>
General .....	160
Continuous running duty (S1) .....	160
Short-time duty (S2) .....	160
Intermittent periodic duty (S3) .....	161
Intermittent periodic duty with starting (S4) .....	162
Intermittent periodic duty with electric braking (S5) .....	163
Continuous-operation periodic duty (S6) .....	164
Continuous-operation periodic duty with electric braking (S7) .....	164
Continuous-operation periodic duty with relative load/speed changes (S8) .....	165
Duty with non-periodic load and speed variations (S9) .....	165
Duty with discreet constant loads and speeds (S10) .....	166
<b>Operation with frequency converter.....</b>	<b>167</b>
Notes on design .....	167
Increased torque with reduced duty factor .....	167
Increased torque with external fan .....	167
Energy-saving function .....	168
Regeneration .....	168
Notes on operation with other-make frequency inverters .....	168
<b>Technical data.....</b>	<b>169</b>
<b>Technical data of the 50 Hz motors.....</b>	<b>169</b>
4-pole IE1 motors for continuous operation S1, line frequency 50 Hz.....	169
4-pole IE2 motors for continuous operation S1, line frequency 50 Hz.....	170
4-pole IE2 motors for continuous operation S1, mains frequency 50 Hz.....	171
4-pole IE3 motors for continuous operation S1, line frequency 50 Hz.....	172
4-pole IE3 motors for continuous operation S1, mains frequency 50 Hz.....	173
4 pole motors for periodic duty S3/S6-75 %, Mains Frequency 50 Hz.....	174
4 pole motors for periodic duty S3/S6, Mains Frequency 50 Hz.....	175
4/2-pole $\Delta$ /YY motors for continuous running duty (S1) and 50 Hz mains frequency .....	176
8/4-pole $\Delta$ /YY motors for continuous running duty (S1) and 50 Hz mains frequency .....	177
8/2-pole Y/Y motors for intermittent periodic duty S3 25/75 % and 50 Hz mains frequency .....	178
12/2-pole Y/Y motors for intermittent periodic duty S3 25/75 % and 50 Hz mains frequency .....	179
<b>Technical data of the 60 Hz motors.....</b>	<b>180</b>
4-pole IE1 motors for continuous operation S1, mains frequency 60 Hz.....	180
4-pole IE2 motors for continuous operation S1, mains frequency 60 Hz.....	181
4-pole IE2 motors for continuous operation S1, mains frequency 60 Hz.....	182
4-pole IE3 motors for continuous operation S1, line frequency 60 Hz.....	183
4-pole IE3 motors for continuous operation S1, mains frequency 60 Hz.....	184
4-pole motors for intermittent periodic duty (S3/S6 75 %) and 60 Hz mains frequency.....	185
4-pole motors for intermittent periodic duty (S3/S6) and 60 Hz mains frequency.....	186
4/2-pole motors $\Delta$ /YY for continuous operation S1, line frequency 60 Hz.....	187
8/4-pole motors $\Delta$ /YY for continuous operation S1, line frequency 60 Hz.....	188
8/2-pole Y/Y motors for intermittent periodic duty S3 25/75 % and 60 Hz mains frequency .....	189
12/2-pole motors Y/Y for intermittent periodic duty S3-25/75 %, line frequency 60 Hz.....	190
<b>Operation with frequency converter, 50 Hz .....</b>	<b>191</b>
IE1 Motor torques for frequency-converter range 5 Hz - 70 Hz, line frequency 50 Hz .....	191
IE1 Motor torques for frequency-converter range 5 Hz - 100 Hz, line frequency 50 Hz .....	192
IE2 Motor torques for frequency-converter range 5 Hz - 70 Hz, line frequency 50 Hz .....	193
IE2 Motor torques for frequency-converter range 5 Hz - 100 Hz, line frequency 50 Hz .....	194
IE3 Motor torques for frequency-converter range 5 Hz - 70 Hz, line frequency 50 Hz .....	195
IE3 Motor torques for frequency-converter range 5 Hz - 100 Hz, line frequency 50 Hz .....	196
<b>Operation with frequency converter, 60 Hz .....</b>	<b>197</b>
IE1 Motor torques for frequency-converter range 6 Hz - 84 Hz, line frequency 60 Hz .....	197
IE1 Motor torques for frequency-converter range 6 Hz - 120 Hz, line frequency 60 Hz .....	198
IE2 Motor torques for frequency-converter range 5 Hz - 80 Hz, line frequency 60 Hz .....	199
IE2 Motor torques for frequency-converter range 5 Hz - 120 Hz, line frequency 60 Hz .....	200
IE3 Motor torques for frequency-converter range 5 Hz - 80 Hz, line frequency 60 Hz .....	201
IE3 Motor torques for frequency-converter range 5 Hz - 120 Hz, line frequency 60 Hz .....	202
<b>12 Motors - BM .....</b>	<b>203</b>
<b>Motor configuration .....</b>	<b>205</b>
Torque-speed characteristic .....	205
<b>Motor configuration .....</b>	<b>206</b>
<b>Technical data.....</b>	<b>209</b>

# Energy Efficient Geared Motors

## Table of contents

<b>Standard Motors</b> .....	<b>209</b>
Motors with rated speed 1500 1/min .....	209
Rated speed 1500 1/min .....	210
Motor-Drehmomente bei Stellbereich 150 1/min - 1800 1/min, Betriebsart S1 .....	211
Motors with rated speed 2250 1/min .....	215
Rated speed 2250 1/min .....	216
Motor-Drehmomente bei Stellbereich 150 1/min - 2600 1/min, Betriebsart S1 .....	217
Motors with rated speed 3000 1/min .....	219
Rated speed 3000 1/min .....	220
Motor torques in the adjusting range 150 1/min - 3600 1/min, duty type S1 .....	222
<b>13 Motor Mounted Components</b> .....	<b>227</b>
<b>Brake</b> .....	<b>229</b>
Functional description .....	229
Product description of type ES(X) spring-actuated brakes .....	229
Product description of type ZS(X) spring-actuated brakes .....	230
Brake selection and sizing .....	231
Electrical connection .....	234
Specifications of holding brakes with emergency stop capability .....	237
Specifications of working brakes .....	238
Connection .....	240
DC connection via terminals (K) .....	240
Standard rectifier (S) .....	241
Rectifier for electronic rapid shutdown (E) .....	242
Rectifier for overexcitation and rapid shutdown (M) .....	243
Brake connection, operation with frequency converter .....	245
Brake connection, pole-changing motors .....	245
Manual release (HA, HN) .....	245
Explosion protection .....	245
Back stop (RR, RL) .....	245
Second motor shaft extension (ZW, ZV) .....	246
Protective fan cowl (D) .....	246
Motor-independent fan (FV) .....	246
Technical Data Motor-independent fan .....	246
<b>Encoder System</b> .....	<b>247</b>
Shaft encoder (G) .....	247
<b>Incremental rotary encoder</b> .....	<b>248</b>
Functional description .....	248
Electrical specifications .....	248
Plug end view with male pin insert .....	248
Signal assignments .....	248
Functional description .....	249
Profibus DP interface .....	249
<b>Absolute rotary encoders</b> .....	<b>250</b>
SSI interface .....	250
<b>14 BAUER global</b> .....	<b>253</b>
<b>North America</b> .....	<b>255</b>
<b>Latin America</b> .....	<b>256</b>
<b>Europe</b> .....	<b>257</b>
<b>Eastern Europe</b> .....	<b>260</b>
<b>Middle East &amp; Africa</b> .....	<b>261</b>
<b>APAC</b> .....	<b>262</b>
<b>China</b> .....	<b>263</b>

# Energy Efficient Geared Motors

## Electric overhead conveyors series BM

---

# Energy Efficient Geared Motors

## Bauer Gear Motor - profile

---

### Innovation since 1927

During its 90-year history, Bauer Gear Motor has developed to become the preferred international provider of high-quality and extremely reliable geared motors. A great deal of knowledge has been accrued over the decades, and this has continually been built upon and shared. Bauer has pioneered many new geared motor solutions and will continue to do so in the future. Our engineers develop technically-advanced solutions that feature energy-efficient motors paired with optimal gearboxes so that we can offer our customers the lowest possible operating costs. It is not without reason that the Bauer brand has become world famous; this is because our geared motor solutions are the driving power in drive technology.



### Competent and customer-focused

We see ourselves as the value adding partner for individual drive technology solutions along the entire customer value chain ... **Uncomplicated ... Competent ... Enduring.** With our global sales and expertise, we are there to support you side by side- right from the design of your drive. Our employees will ensure that you have the optimum geared motor solution for your application

Our quick response time to requests ensures that you receive the required offer within 24 hours. After your order has arrived, we check your order details and you will receive a confirmation of the order within 24 hours. This means that you will have the details for your own production planning process by the following day.

As we concentrate our production in regional factories, we are also able to deliver customised solutions from the factory reliably and directly, with an extremely short delivery period.

# Energy Efficient Geared Motors

## Bauer Gear Motor - profile

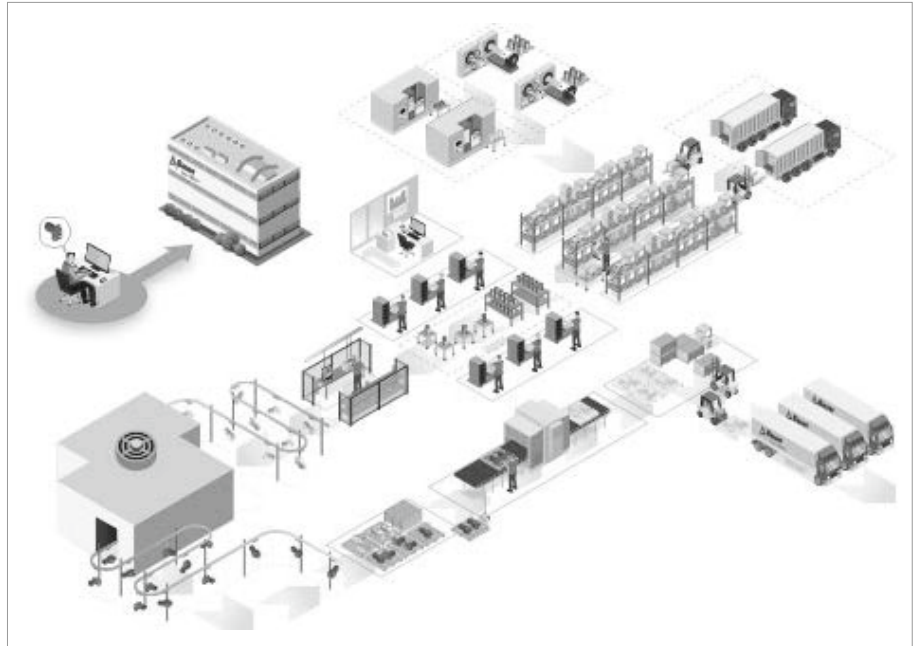

### Closer to the customer's needs thanks to greater flexibility

Orders are processed immediately and passed on to our production team. By reducing set-up times, we are able to start producing the order specific parts right away. This is synchronised with assembly, ensuring that the parts are available according to just-in-time principles.

The entire manufacturing processes starting from the production of the motor, the mechanical geared motor parts and the electrical components, are perfectly coordinated to ensure greater process reliability and availability. This means that a high delivery reliability of over 95% can be achieved, while maintaining Bauer's high quality.

### The product range



# Energy Efficient Geared Motors

## Bauer Gear Motor - profile

---

### Helical Geared Motors

- Power range from 0.03 kW to 75 kW
- 13 gear sizes for torques ranging from 20 Nm to 18500 Nm
- New attachment possibilities with low design height
- High efficiency through 2-stage base design
- High protection rating of IP65 as standard

### Shaft Mounted Geared Motors

- Power range from 0.03 kW to 75 kW
- 10 gear sizes for torques ranging from 90 Nm to 18500 Nm
- Gearbox housing with integral torque arm
- High efficiency through 2-stage base design
- High protection rating of IP65 as standard

### Bevel Geared Motors

- Power range from 0.03 kW to 75 kW
- 10 gearbox sizes for torques ranging from 80 Nm to 18500 Nm
- Right angle with universal, space-saving mounting options
- High efficiency through 2-stage base design
- High protection rating of IP65 as standard

### Worm Geared Motors

- Power range from 0.03 kW to 5.5 kW
- 8 gearbox sizes for torques ranging from 25 Nm to 1000 Nm
- Hollow shaft version available from 25 Nm
- Heavy duty worm gearing for a long service life
- High protection rating of IP65 as standard

### Monorail Geared Motor Drives

- Torque rating from 30 Nm to 680 Nm
- Radial force up to 25,000 N
- Gearboxes with a wide range of mounting options
- High protection rating of IP65 as standard
- Improved efficiency
- low energy consumption - ideal for travel drives
- Reverse motion of gearbox possible with released brake

### AsepticDRIVE

- Motor without cooling ribs and fan
- Available with helical, shaft-mounted, bevel and worm gearboxes
- Motor winding with thermistors and ISO class F as standard
- IP67 and IP69K protection ratings with alkali and acid-resistant coating as standard.
- Motor connection through standard, round stainless steel connector

### CleanDRIVE

- Motor without cooling ribs and fan
- Available with helical, shaft-mounted, bevel and worm gearboxes
- Motor winding with thermistors and ISO class F as standard
- Motor connection through a standard terminal box or stainless steel cable gland



### HiflexDRIVE

#### BK04 gearbox

- Torque 80 Nm
- Gear reductions 7.25 – 63.33

#### BK08 gearbox

- Torque 200 Nm
- Gear reductions 4.44 - 102.5

#### BK17 gearbox

- Torque 330 Nm
- Gear reductions 4.54 - 108.6

#### Motors

- Output power 0.12 kW ... 3.0 kW
- Efficiency classes no rating and IE1 to IE4
- Enclosure IP65 (standard)  
IP67 / IP69K (optional)

### Energy-efficient motor solutions

#### Mains Supply

- IE1 asynchronous technology 0.12 kW – 45 kW
- IE2 asynchronous technology 0.12 kW – 45 kW
- IE3 asynchronous technology 0.12 kW – 45 kW
- IE4 asynchronous technology 0.55 kW – 4 kW

#### Inverter Duty

- IE3 PMSM-technology 1.5 kW – 15 kW
- IE4 PMSM-technology 0.55 kW – 11 kW

### Energy-efficient motor solutions for explosion hazard areas

The S series in permanent magnet synchronous motors (PMSMs) offers variable-speed geared motors in efficiency class IE4 for use in explosion hazard areas<sup>[1]</sup>.

- Design torque  $M_N$ : 5 Nm – 48 Nm
- Rated power  $P_N$ : 0.75 kW – 15 kW
- Increased safety for zone 1 II 2 G Ex e IIC T1 - T3 Gb
- Dust explosion protection – Zone 21 II 2 D Ex tb IIIC T 160°C ... 120° Db

<sup>[1]</sup> Individual motor designs can show lower efficiency classes than IE4 at rated torque.

### EtaK2.0 Decentral Solutions

- PMSM enabled
- Integrated safety technology and field bus communication according to specific needs
- Modular structure minimises spare parts stock
- Energy savings of up to 30 % possible under partial load conditions
- Suited to extremely harsh environments thanks to IP65 enclosure rating
- 200 % overload current (3 s)
- Sensorless vector control
- CANopen, Profibus, Profinet, EtherCAT, EtherNet/IP and AS-Interface
- STO safety function

# Energy Efficient Geared Motors

## Bauer Gear Motor - profile

---

### Submersible Solutions

- **Special sealing concepts** for maximum leakage protection
- **Reinforced bearings** for higher strength and longer service life
- **Shafts** available on request in V4A steel or coating
- **Motor Connection**
  - Standard with cast terminal box
  - Optional with special plug connection
- **Additional features:**
  - Special design for continuous submersible operation
  - Electronic leakage detection available on request
  - Brakes available in IP68 design
  - Water depths of 5m (deeper on request)
- **Corrosion category Im2** based on DIN ISO 12944-5

### Customised geared motor solutions for all applications

- Special applications
- Special adaptations
- Special environments
- Series production

Based on our modular, geared motor programme, we offer specific solutions for applications in all key markets such as, for example, food & beverage, energy, wastewater, concrete, metals and material handling in applications such as washdown conveyor systems, rolling mills, monorail systems and overhead conveyors, sludge thickeners, cranes, fans and blowers and turbines. Our aim is to provide our customers with products tailored to their needs. At the same time, we take care to ensure that a geared motor solution will prove to be especially profitable throughout its entire life cycle.

We already equip our geared motors with highly efficient permanent magnet motors to achieve low life cycle costs because low energy consumption will be particularly important in the future. We are very confident that we are once again pioneers in this sector

Learn more about Bauer Gear Motor, its products and philosophy at [www.bauergears.com](http://www.bauergears.com).



### General

<b>Advantages of Bauer-Geared Motors .....</b>	<b>15</b>
Bauer-electric overhead conveyors systems .....	15
Bauer Gearboxes .....	15
Bauer Motors .....	15
Bauer Brakes .....	15

# Energy Efficient Geared Motors

## Electric overhead conveyors series BM

---

1

### Bauer-electric overhead conveyors systems

What we offer...	Your benefit...
Tried and tested technology with several thousand drives in the field	Reliability
Flexible assembly possibility	Simple engineering
Coupling lever always on the front side	Simple engineering, easy to reach
Gearboxes designed for efficiency	Energy saving
Industry standard shaft connection	Flexible choice of wheel
Long service intervals	High productivity
Finely graduated brake torques	High availability
Asynchronous and permanent magnet technology	High flexibility in engineering reduces stocking costs and increases the working capital
Permanent magnet synchronous motors	Energy saving, high power density, weight reduction
Customer specific modifications	Flexibility
Drives can be reversed without disengaging the clutch	Reduced downtime

### Bauer Gearboxes

Easy access to the fixation points reduces assembly times and installation costs

- Low servicing costs as the lubrication change results in normal duty with a lubrication temperature of approx. 80 °C first after 15.000 operating hours when using CLP oils or 25.000 operating hours when using PGLP oils
- 2-stage gearbox concept reduces the spare part stocking
- A variety of attachment possibilities (Foot, Flange, Solid and Hollow shafts, Torque arms)
- Sealed housing design reduces the risk of oil leakage and increases the oil lifetime
- The large housing volume allows usage in very harsh environments

### Bauer Motors

- Low operating costs due to high motor efficiencies (IE2, IE3 and IE4 as Standard)
- Low installation costs through CAGE CLAMP® instead of the classical terminal block connection
- A variety of additional designs (connectors, brakes, backstops, rain covers, forced cooling, encoders etc.)
- Cost reduction of connection cabling and avoidance of additional protective elements (chokes, filters etc.), through built-on inverters (ETA-K)
- Ideal for frequency inverter

### Bauer Brakes

- Low servicing costs through long lifetime of the brake discs
- Brake-Motor correlation tailor made to the application by virtue of on average three brake sizes per motor size
- A variety of designs (lockable and non-lockable hand release, microswitch, heaters)
- Robust design for heavy duty applications
- Enclosure IP65 as standard
- Very high wear resistance.

# Energy Efficient Geared Motors

## Electric overhead conveyors series BM

---





# 2

### Product Description

<b>Selection of geared motors</b> .....	<b>19</b>
Installed positions of geared motors .....	19
Notes on safety .....	19
Guards for rotating parts .....	19
Touch protection .....	19
Operating noise .....	19
Painting and corrosion protection .....	19
<b>Description of BM geared motors</b> .....	<b>20</b>
Five unit sizes to handle every load .....	20



- Installed positions of geared motors** Bauer geared motors can be supplied for any type of fitting position. Vertical installation positions (motor-down) place a particularly severe strain on the shaft seal. It is advisable to avoid this arrangement especially at high motor speeds (e.g. above 1800 r/min) and continuous operation.
- Notes on safety** See the notes on safety regarding installation in Operating Instructions.
- Guards for rotating parts** The shrink disk (SSV) guards required under the German law relating to technical materials (Law Concerning Industrial Equipment - Equipment safety law GPSG) or by the Accident Prevention Regulations (UVV) are not included in the standard scope of supply because they are fitted by the customer in most cases, or the risk of accident can be eliminated by suitable installation.
- See the Operating Instruction.
- Touch protection** The fan hoods, via the externally mounted fan wheels, of the entire B2000 motor series fulfil the protection against contact with the standard finger (Ø12 mm).
- Operating noise** The typical operating noise levels of BAUER geared motors are within the limits stipulated by VDI directive 2159 for gears and EN 60034-9, Table 2 for motors.
- For physical reasons, low-ratio, high-speed gears produce more noise than medium- and high-ratio gears operating at low speeds.
- Painting and corrosion protection** BAUER geared motors are spray-painted in RAL 7031 to DIN 1843 as standard. Other RAL colours are available at extra cost.
- The output shafts are shipped in protective sleeves or with a protective coating to prevent corrosion.
- The prerequisite for achieving a long protection period is the right choice of coating. The coating system from Bauer Gear Motor GmbH, based on DIN EN 12944-5, offers suitable and long-lasting corrosion protection for all areas of application.

Category	Loads	Examples of indoor areas	Examples of outdoor areas	Possible IP-Protection class
Standard	Insignificant	Insulated and heated buildings with neutral atmosphere	—	IP54 IP65
C1	Insignificant	Insulated and heated buildings with neutral atmosphere	—	IP54 IP65
C2	Low	Uninsulated and unheated buildings where condensation can occur, e.g. warehouses, sports halls	Atmosphere with low corrosive load, mostly rural areas	IP54 IP65
C3	Moderate	Production rooms with high relative humidity and some air pollution, e.g. facilities for food production, laundries, breweries, dairies	Urban and industrial atmosphere, moderate pollution by sulphur dioxide. Moderate coastal area with low salt pollution	IP65 IP66
C4	Strong	chemical plants, swimming pools, objects above sea water	Industrial and coastal areas with moderate salt exposure	IP65 IP66
C5-I	Very strong (industry)	areas with almost constant condensation and heavy contamination	Industrial areas with high relative humidity and aggressive atmosphere	IP66
C5-M	Very strong (sea)	areas with almost constant condensation and heavy contamination	Coastal and offshore areas with high salt pollution, buildings with almost constant condensation and heavy air pollution	IP66
IM2	Sea or brackish water	IP68 Underwater Drives	Port areas, lock gates, moles, offshore installations	IP68
Aseptics (proprietary development of Bauer)	Very strong	For indoor and outdoor use with very high environmental pollution and in hygiene-sensitive areas, in each case with high-pressure cleaning with chemical cleaning agents		IP67/IP69K

Duration of protection according to DIN EN ISO 12944-5: medium (M) 5 to 15 years

# Product Description

## Description of BM geared motors

### Five unit sizes to handle every load

The BM (Bauer Monorail) series offers five gear unit sizes which differ in their permissible torques (from 50 to 680 Nm). The gear units are also offered in heavy duty versions for increased permissible radial loads.

2

Gear unit		$F_{RN}$ in N	$d_{AW}$ in mm	Shaft height in mm	Shaft collar in mm
1	BM09	4400	20	61	30
	BM09X	6500	25	61	30
2	BM10	8000	25	62,5 (60)	34,5
	BM10X	10000	25	62,5 (60)	34,5
3	BM20	10000	30	70,5 (68)	35
	BM20X	12000	30	70,5 (68)	35
4	BM30(Z)	12000	35	94 (90)	45
	BM30(Z)X	15000	35	94 (90)	45
5	BM40(Z)	20000	55	125 (120)	60
	BM40(Z)X	25000	55	125 (120)	60

Type	Allowable torque [Nm]	Allowable wheel load at power application *ML [N]	Gear ratios	Speed (based on wheel) [m/min]	Wheel diameter [mm]	Output shaft [mm]
BM09	30 - 100	4400	11.34 - 53.85	10 - 100	125	20 x 35
BM09X	-	6500	-	12.8 - 128	160	25 x 35
BM10	140 - 160	8000	11.68 - 58.18	12 - 128	160	25 x 35
BM10X	-	10000	-	16 - 160	200	25 x 35
BM20	182 - 220	10000	7.66 - 74.76	9 - 69	160	30 x 35
BM20X	-	12000	-	12 - 87	200	30 x 35
BM30	260 - 350	12000	7.91 - 71.09	13 - 186	200	35 x 49
BM30X	-	15000	-	16 - 233	250	35 x 49
BM40	600 - 680	20000	11.17 - 104	11 - 162	250	55 x 110
BM40X	-	25000	-	13 - 194	300	55 x 110

\*ML: The position of the power application point „centre of wheel“ can be seen on the applicable dimensional drawings. Significantly higher gear ratios are optional.

The BM09 and BM10 gear units can run on “C1 profiles”. Compliance with the VDI Code of practice 3643 (C1-Standard) and the need to reduce the cost of overhead conveyor drives of this size resulted in a thoroughly tested design which uses a worm-gear set in the first stage and a spur gear set in the second stage. The worm-gear stage with its very small reduction ratios offers particularly high levels of efficiency (greater than 85 %) thanks to the high speeds. The mechanical claw clutch engages the first stage on the BM09 and the final stage on the BM10.

BM20, BM30 and BM40 are heavy-load overhead conveyor drives and have a helical-gear set in the first stage and a bevel-gear set in the final stage. The clutch is mounted in the final stage on these gear units also.

The BM10, BM20, BM30 and BM40 offer additional mounting options. The flange can be located outside on the front of the gear unit, or on the back (“H” side). A version with sturdy securing threads on the underside (“U”) and on top (“O”) of the gear unit can also be supplied. This enables new and easy - to - maintain carriage designs. The use of BM gear units as drive units for floor conveyors is simplified by the version with an output shaft on both sides. Hollow shaft design available on request.

# Energy Efficient Geared Motors

## Electric overhead conveyors series BM

# 3

<b>BAUER</b>		73734 Esslingen Made in Germany	
S-Mot.-No. e 11873812-1	A/ 188W573	40/2022	
Type <b>BM30-61UO/D08MA4-TF-ST-S/E008B6HM/</b>			
<b>TM</b>			
0,55 kW	cosφ	0,75	S1
50 Hz	400 V		1,6 A
n <sub>s</sub> 1400	n <sub>e</sub> 28,5 r/min	i	49,66
20-50-60 Hz 186-400-400 V		0,21-0,47-0,57 kW	
B34001123803	FU	100 %	
M H1	IP 65	1,2 L PGLP 460	
T <sub>amb</sub> -20...40 °C		49,4 kg	
180 V DC	0,15 A	6,5 Nm	380...420 V AC 0,11 A
CE		SCH01 EN60034	

## Type Designations

<b>Significance of type designation</b> .....	<b>23</b>
Significance of type designation .....	23
<b>Electric overhead conveyors series BM</b> .....	<b>24</b>
<b>Versions and options</b> .....	<b>25</b>
Gear unit designs .....	25
Type designation and components of the BM-series geared motors.....	25
<b>Motor</b> .....	<b>26</b>
Three-phase motor .....	26
Motor protection .....	26
Brake rectifier in motor terminal box .....	26
Plug connector .....	26
Heavy-duty fan .....	26
Protective cover .....	26
<b>Motor Mounted Components</b> .....	<b>27</b>
Brake .....	27
Reverse rotation block.....	27
Encoders .....	27
Second shaft end .....	27
Forced ventilation .....	27
Overall design .....	27

# Energy Efficient Geared Motors

## Electric overhead conveyors series BM

---

3



### Example: Monorail geared motor with brake and series options

#### Significance of type designation

The type designation of a BAUER geared motor is a code designating all the features in the drive configuration.

The type designation of a BAUER geared motor is a code designating of all the features in the drive configuration. The build-up of the type designation is explained with the help of the following example of a monorail geared motor with brake and series options.

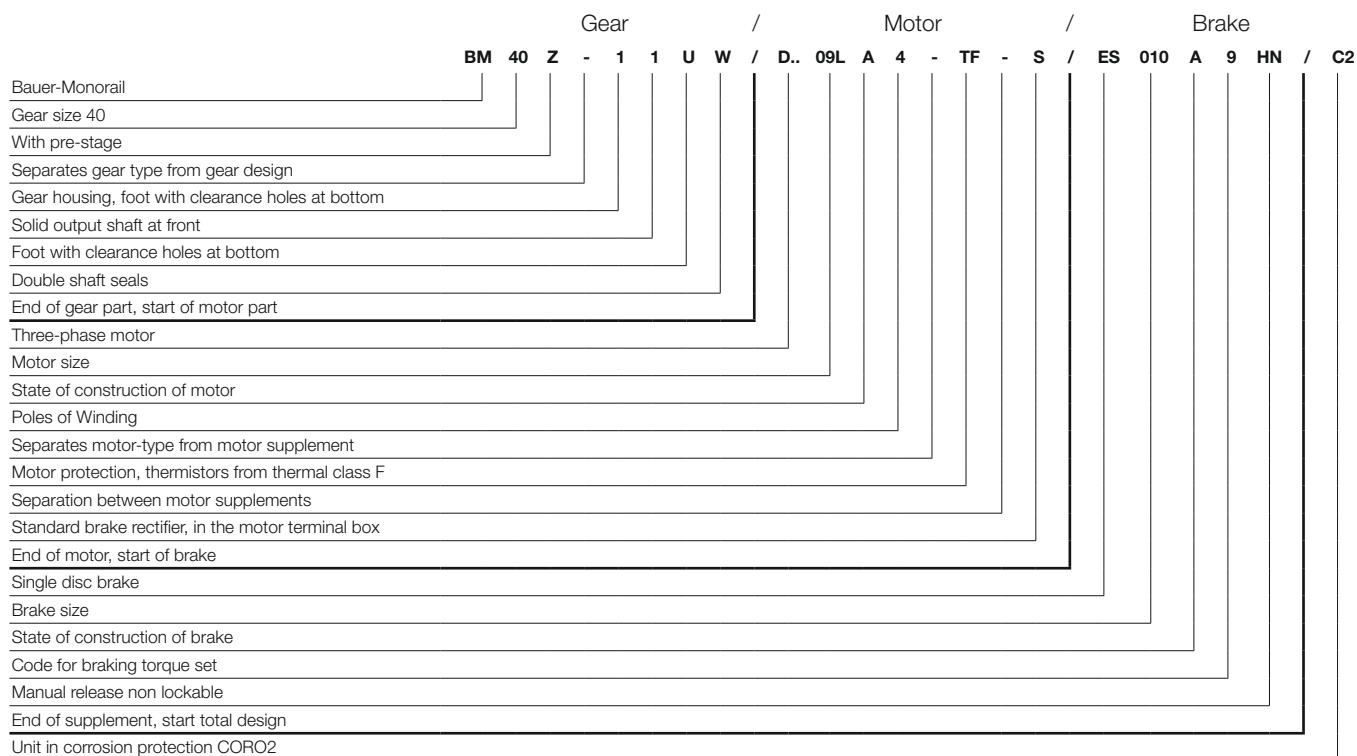

# Type Designations

## Electric overhead conveyors series BM

3

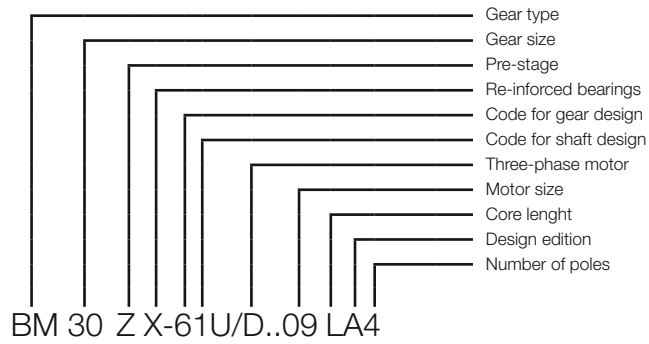

- 6 . 0 ——— Foot with threaded holes, top
- 6 . U ——— Foot with threaded holes, bottom
- 6 . UO ——— Foot with threaded holes, bottom and top

- 7 . V ——— C-flange with threaded holes, front
- 7 . H ——— C-flange with threaded holes, rear

- 8 . ——— completely machined
- 07 . V /.../ S02 ——— wide protruding front flange

- 07 . V /.../ S01 ——— Front advanced flange

- . 1 ——— Solid shaft on gear side V
- . 2 ——— Solid shaft on gear side H
- . 3 ——— Solid shaft on gear side V and H

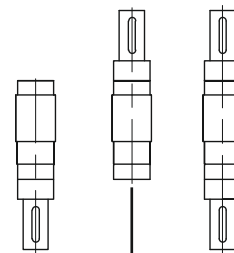
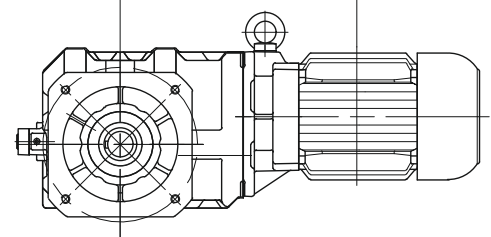
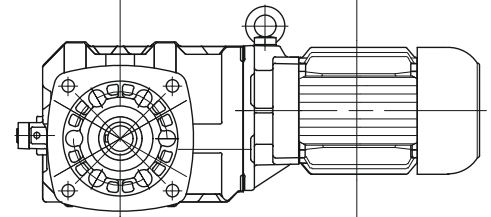
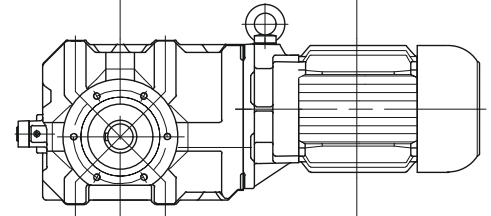
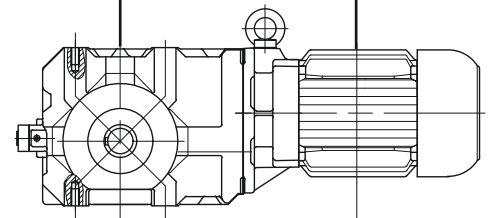
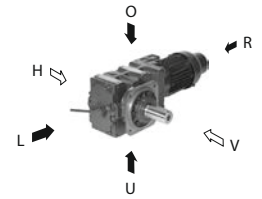

### Gear unit designs

Gear unit	1st stage	2nd stage	Flange on rear	“U”and “O” foot threads	Output shaft on both sides	Output shaft on rear	Preferred flange
BM09(X)	Worm-gear	Helical-gear	-	-	-	-	-
BM10(X)	Worm-gear	Helical-gear	Option	Option	Option	-	-
BM20(X)	Helical-gear	Bevel-gear	Option	Option	Option	-	-
BM30Z(X)	Helical-gear	Bevel-gear	Option	Option	Option	-	Option
BM40Z(X)	Helical-gear	Bevel-gear	Option	Option	Option	Option	Option

### Type designation and components of the BM-series geared motors

BM..-	Bauer Monorail geared motor Gear unit size (BM09,10, 20, 30, 40)
BM..Z-..	Gear unit with additional primary stage for very high reduction ratios
BM..G-..	Gear unit with double gearing for very high reduction ratios
BM..X-..	Reinforced gear unit for high wheel loads
BM..-7.V	C-flange with threaded holes on the “V” side of the gear unit
BM..-7.H	C-flange with threaded holes on the “H” side of the gear unit (available on request)
BM..-6.UO/	Foot thread on the “U” and “O” sides of the gear unit (not with BM09)
BM..-.1/	Solid shaft on the “V” side of the gear unit
BM..-.2/	Solid shaft on the “H” side of the gear unit (available on request)
BM..-.3/	Solid shaft on the “V” and “H” sides of the motor (available on request)
BM..-07V/..S01	A-flange and solid shaft extended on the V side of the gear unit (BM30; BM40)
BM..-07V/..S02	A-flange and solid shaft “greatly” extended on the V side of the gear unit (BM30; BM40)

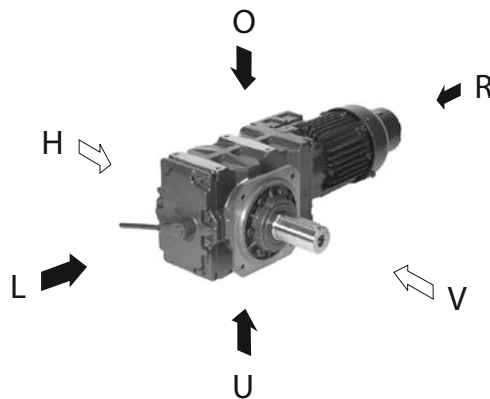

V =	Front The side of the gear unit facing toward the viewer looking toward the type H1 unit
H =	Rear The side of the gear unit facing away from the viewer looking toward the type H1 unit
L =	Left The left side of the gear unit as viewed from the output shaft side of type H1, or the torque brace oriented to the left
O =	Top The top side of the gear unit as viewed from the output shaft side of type H1, or the torque brace oriented upwards
U =	Bottom The bottom side of the gear unit as viewed from the output shaft side of type H1, or the torque brace oriented downwards

# Type Designations

## Motor

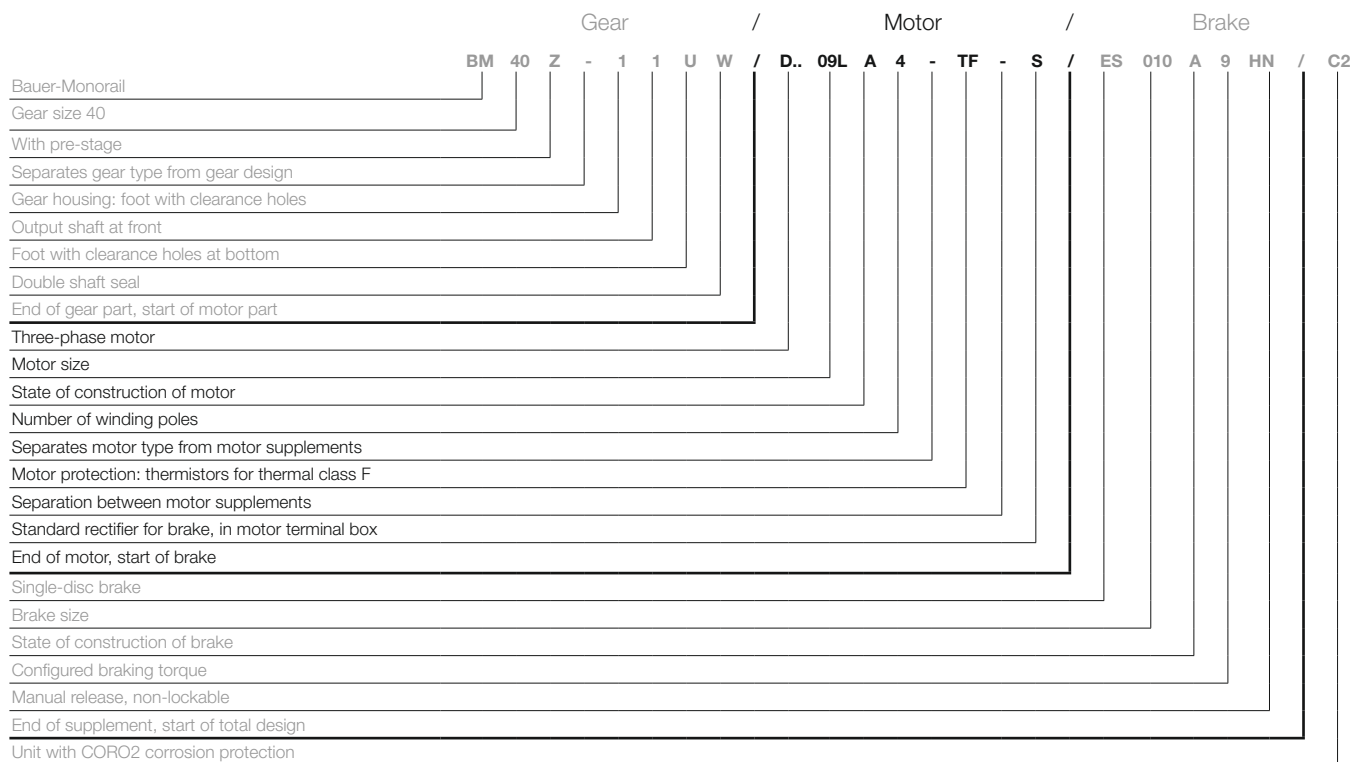

### Three-phase motor

D	=	Three-phase motor
E	=	Single-phase motor (Steinmetz circuit)
S	=	PM-Synchronous motor
.	A	Aseptic motor (germ-free drive)
.	SE	Three-phase motor with enhanced efficiency compliant with IE1
.	HE	Three-phase motor with enhanced efficiency compliant with IE2
.	PE	Three-phase motor with enhanced efficiency compliant with IE3
.	N	Motor without gear unit; foot-mount version
.	NF	Motor without gear unit; flange-mount version
.	R	Roller table motor
.	XE	Explosion-proof motor with increased safety
.	XD	Explosion-proof motors
.	W	Torque motor
.	L	Special rotor for traction and slewing gear motors
.	C	With main and auxiliary windings; only with single-phase motors (EC....)
.	V	Multiple voltage ranges (wide voltage range)
.	U	Unventilated (no forced ventilation)

### Motor protection

TB	=	Thermistor 140°
TF	=	Thermistor 160°
TH	=	Thermistor 180°
TEB	=	Thermistor warning/shutdown 120°/140°
TBF	=	Thermistor warning/shutdown 140°/160°
TFH	=	Thermistor warning/shutdown 160°/180°
TOB	=	Thermostatic switch, NC 140°
TOF	=	Thermostatic switch, NC 160°
TOH	=	Thermostatic switch, NC 180°
TSB	=	Thermostatic switch, NO 125°
TSF	=	Thermostatic switch, NO 160°
TSH	=	Thermostatic switch, NO 180°
TX	=	Other

### Brake rectifier in motor terminal box

S	=	Standard rectifier	SG
E	=	Special rectifier	ESG
M	=	Special rectifier	MSG

### Plug connector Heavy-duty fan Protective cover

ST	=	Harting (other)
SL		
D		

# Type Designations

## Motor Mounted Components

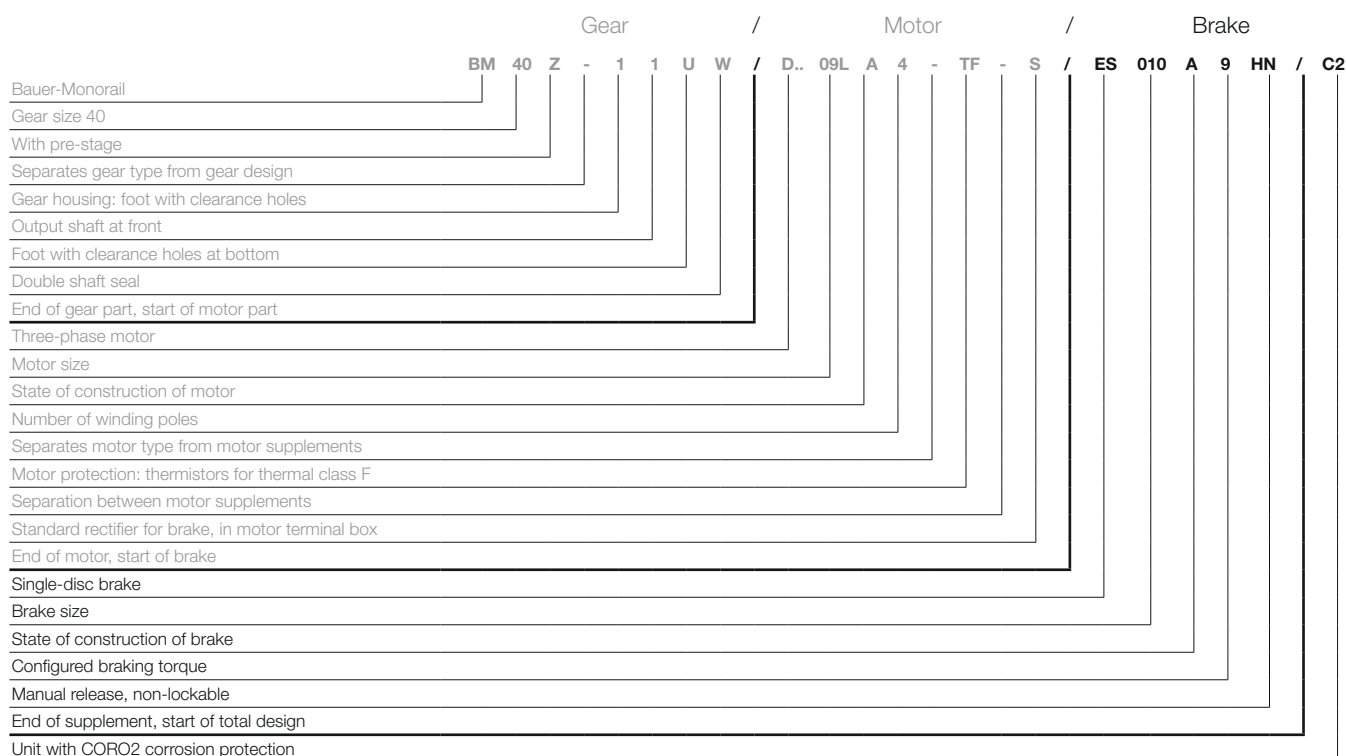

3

### Brake

- E = Single-disc brake
- ES = Single-disc holding brake
- EH = Single-disc holding brake in heavy duty
- ZS = Two-disc holding brake
- ESX = Single-disc service brake
- EHX = Single-disc service brake in heavy duty version
- ZSX = Two-disc service brake
- ... 010 = Brake size
- ... .. A = Construction state
- ... .. . 9 = Code for configured braking torque
- ... .. . . HN = Manual release (not lockable)
- ... .. . . HA = Manual release (lockable)

### Reverse rotation block

- RR = Blocking direction clockwise
- RL = Blocking direction counterclockwise

### Encoders

G

### Second shaft end

- ZW = With parallel key
- ZV = With square shaft

### Forced ventilation

FV

### Overall design

- AV = USA/Canada version with shaft dimensions in inches
- AM = USA/Canada version with metric shaft dimensions
- UL = US version
- CS = Canadian version
- C1 = Coro1 corrosion protection
- C2 = Coro2 corrosion protection
- C3 = Coro3 corrosion protection
- C4 = Coro4 corrosion protection
- C5I = Coro5 corrosion protection
- C5M = Coro5 corrosion protection
- IM2 = Protection against sea or brackish water
- SP = Non-catalogue version

# Energy Efficient Geared Motors

## Electric overhead conveyors series BM

---





# 4

## **Gear Motor Selection**

<b>Project planning advice .....</b>	<b>31</b>
Procedure for selecting BM-series geared motors .....	31
Carriage design .....	34
<b>Selection of geared motors .....</b>	<b>36</b>

# Energy Efficient Geared Motors

## Electric overhead conveyors series BM

---

4

Bauer has an experienced team of experts available for the dimensioning of EHB carriage drives.

If you give a precise description of the conditions of operation, using our questionnaire (see 14.2), a quote for the best drive for you can be processed as quickly as possible.

For frequently used applications where the drives are supplied from a frequency inverter, however, the selection tables below can be used for rough drive dimensioning.

### Procedure for selecting BM-series geared motors

#### 1) Establish the wheel load and running wheel diameter

$$F_A = m_A \cdot g$$

$F_A$	[N]	(Wheel load on running wheel)
$m_A$	[kg]	(Mass acting on the drive wheel)
$g$	[9,81 m/s <sup>2</sup> ]	Acceleration due to gravity
$F_{RN}$	[N]	(Maximum permissible radial force at the centre, of the wheel, see table „permissible radial forces“)

Selection is based on the following:  $F_A < F_{RN}$

Running wheel diameter  $d$  is determined by the plant engineer (preferred diameters: 125 mm, 160 mm, 200 mm, 300 mm). Criteria are wheel load and carriage design, for example.

#### 2) The travelling speed is a further important criterion in the selection tables.

Two setting ranges are available for selection: 1:10 and 1:20. The full range of rated torques up to these frequencies are available. At higher frequencies, the torque decreases as a result of the speed range under field control. As a rule, geared motors with the 1:10 setting range are somewhat quieter in operation and those with the 1:20 setting range have smaller, less expensive motor components. The 1:20 setting range facilitates lower positioning speeds.

$$n_2 = \frac{v}{d \cdot \pi}$$

$v$	[m/min]	(Travelling speed)
$n_2$	[1/min]	(Speed at the output shaft)
$d$	[m]	(Running wheel diameter)

#### 3) Geared motor selection in accordance with the required acceleration torque $M_{acc2}$ (specification: $M_{acc2} > M_{tot}$ ) and the permissible long-term rated torque $M_{N2}$ (specification: $M_{N2} > M_r + M_h$ ).

The values for  $M_{acc2}$  and  $M_{N2}$  are contained in the selection tables. If acceleration torque  $M_{acc2}$  is not sufficient, the table usually provides higher values for torques  $M_{acc2}$  and  $M_{N2}$  at a higher permissible radial force  $F_{RN}$ .

Torque from rolling friction [Nm]:

$$M_w = F_w \cdot \frac{d}{2} = m \cdot f_w \cdot \frac{d}{2}$$

Lift on gradient: [Nm]:

$$M_h = m \cdot g \cdot \sin \alpha \cdot \frac{d}{2}$$

Acceleration torque [Nm]:

$$M_a = m \cdot a \cdot \frac{d}{2} = m \cdot \frac{v}{t_a} \cdot \frac{d}{2}$$

### Total torque required during acceleration [Nm]:

$$M_{\text{tot}} = M_W + M_h + M_a$$

$M_{\text{acc2}}$  = Torque [Nm] available at the output shaft during acceleration

$M_{N2}$  = Torque [Nm] available at the output shaft during continuous operation.

d	[m]	(Running wheel diameter)
m	[kg]	(Moving mass)
$f_w$	[N/kg]	(Rolling resistance from rolling friction per 1000 kg , guide value approximately ca. 200 N / 1000 kg = 0.2 N/kg)
$F_w$	[N]	(Rolling resistance from rolling friction)
v	[m/s]	(Maximum travelling speed)
$t_a$	[s]	(Run-up time)
a	[m/s <sup>2</sup> ]	(Acceleration, standard values approximately 0,3 m/s <sup>2</sup> ...1 m/s <sup>2</sup> )
$\alpha$	[°]	(Angle of inclination)

### 4) Establishing the brake size in the brake selection table.

Choose a brake which can be fitted externally and then select the required braking torque.

Guide value for braking torque on the forizontal  $M_{br1} = 0,9 M_{N1}$ .

Total load and rotor at the moment of inertia at the rotor shaft [kgm<sup>2</sup>]

$$J_{\text{tot1}} = J_{\text{Last1}} + J_{\text{rot}} (+J_{\text{SL}}) \quad (J_{\text{SL}}, \text{ with heavy cast-iron fan impeller})$$

Load at the moment of inertia at the rotor shaft [kgm<sup>2</sup>]

$$J_{\text{Last1}} = m \cdot \frac{\left(\frac{d}{2}\right)^2}{i^2} \quad \text{oder} \quad J_{\text{Last1}} = 91,2 \cdot m \cdot \frac{v^2}{n_1^2}$$

Braking time [s]:

$$t_{br} = \frac{J_{\text{tot1}} \cdot n_1}{9,55 \cdot M_{br}}$$

$n_1$	[1/min]	Rotor shaft speed
$M_{br}$	[Nm]	Brake torque of the mechanical brake

$$a_{br} = \frac{v}{t_{br}}$$

Rate of deceleration [m/s<sup>2</sup>]:

v	[m/s]	Travelling speed
$a_{br}$	[m/s <sup>2</sup> ]	Rate of deceleration

The calculated rate of deceleration  $a_{br}$  is a guide value which is exceeded somewhat in practice since the rolling resistance and level of efficiency are not taken into account.

d	[m]	(Running wheel diameter)
m	[kg]	(Moving mass)
i		Gear reduction ratio
v	[m/s]	Travelling speed
$n_1$	[1/min]	Rotor shaft speed
$J_{\text{rot}}$	[kgm <sup>2</sup> ]	Moment of inertia of the rotor at the rotor shaft from the motor table
$J_{\text{SL}}$	[kgm <sup>2</sup> ]	Moment of inertia of the heavy cast-iron fan from the motor table

5) Compare the dimensional drawing of the geared motor with the carriage design, and determine the position of the terminal box.

6) Compare the electrical data of the motor (IN und Iacc) with the data of the inverter supplied.

### Permissible radial forces

$d_{\text{Wheel}}$ in mm	$F_{\text{RN}}$ in N	Gear unit type	$D_{\text{Shaft}}$ in mm
125	4400	BM09	20
125	6500	BM09X	25
125	8000	BM10	25
160	6500	BM09X	25
160	8000	BM10	25
200	8000	BM10	25
200	10000	BM10X	25
200	10000	BM20	30
200	12000	BM20X	30
200	12000	BM30(Z)	35
200	15000	BM30(Z)X	35
250	15000	BM30(Z)	35
250	20000	BM40(Z)	55
300	20000	BM40(Z)	55
300	25000	BM40(Z)X	55

Definition of force on wheel

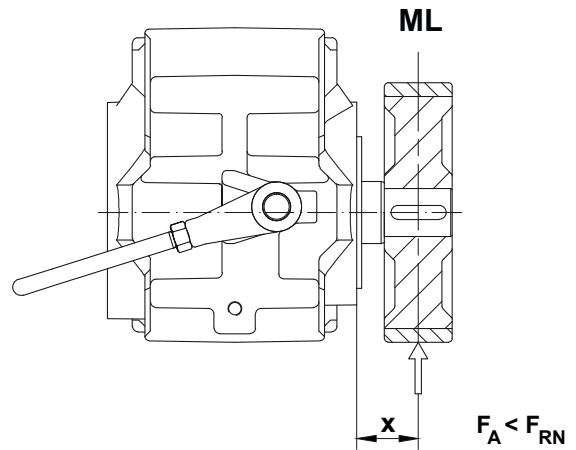

Dimension x, see related drawing

Abbreviations in the selection tables:

$v$	Travelling speed of the wheel diameter at a synchronous speed
$i$	Gear reduction ratio
$M_{\text{acc}2}$	Acceleration torque at the output shaft
$M_{N2}$	Permissible permanent load torque at the output shaft between 30 and 50 or 30 and 87 Hz in inverter duty
$I_{\text{acc}}$	Acceleration current (must be produced by the inverter)
$I_L$	Required current in inverter duty with $M_L = M_{N2}$
$P$	Rated output
$n_2$	Rated speed of the output shaft on a 50 Hz system
$F_{\text{RN}}$	Permissible radial force at the centre of the wheel (see dimension diagram)
$d_{\text{Wheel}}$	Running wheel diameter
$d_{\text{AW}}$	Output shaft diameter

# Gear Motor Selection

## Project planning advice



### Carriage design

Prinzip „X/X“ = „/“ (Please enter principle used)

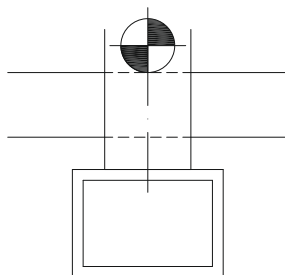
Prinzip „1/1“: One running wheel / one driven wheel



#### Legend:

- S Load centre of gravity
- Z Distance from rail to load centre of gravity
- X Distance between running wheels
- Y Distance between pivot joints
- A, A<sub>1</sub>, A<sub>2</sub> Distance from middle of running wheel to centre of gravity
-  Driven wheel
-  Non-driven wheel

Prinzip „1/2“: Two running wheels / one driven wheel

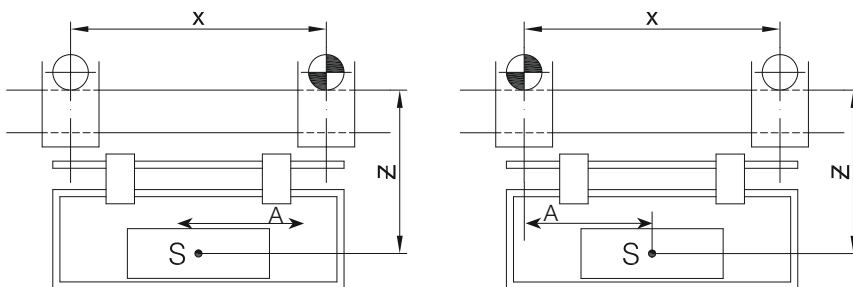

Prinzip „2/2“: Two running wheels / two driven wheels

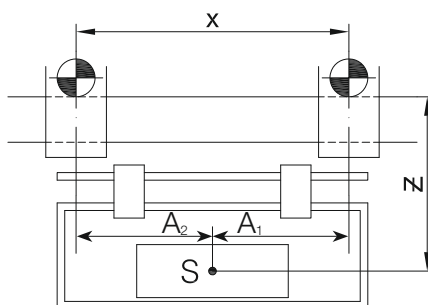

Prinzip „1/4“: four running wheels/with one driven wheel per trolley

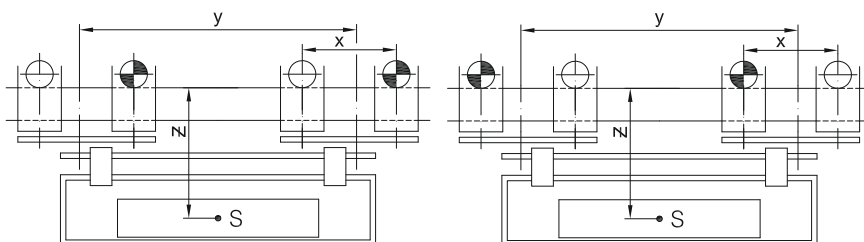

Prinzip „2/4“: four running wheels/two driven wheels per trolley

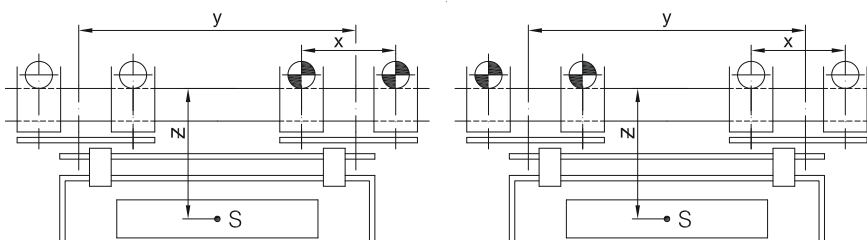

Note, „Principle 2/2“ and „Principle 2/4“ both involve carriages with two drives. Particular attention must be paid to cornering in such cases since different speeds will be present on the two drives when entering and exiting the corner; in practice this is resolved by the different motor slip on the two drives. This can cause considerable additional loading on the gear unit and motor, particularly where curves are tight and there are large distances between the drives wheels.

**Please provide a sketch of your own principle here:**

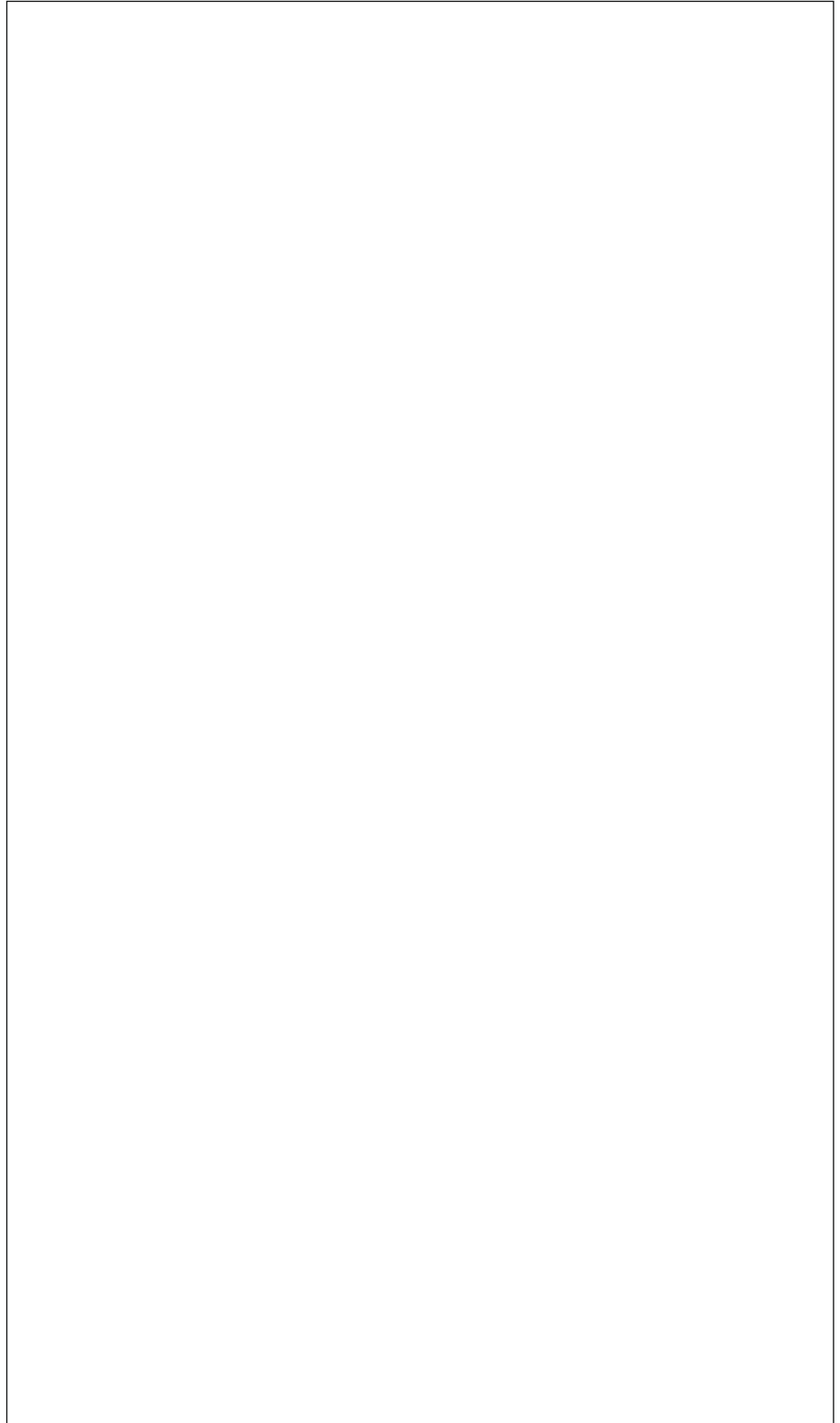

# Gear Motor Selection

## Selection of geared motors

**BAUER GEAR MOTOR**  
A REGAL REYNOLD BRAND



Bauer Gear Motor GmbH  
Eberhard-Bauer-Str. 37 73734 Esslingen  
+49 (0) 711 3518-0 www.bauergears.com

Information

Company: \_\_\_\_\_

Contact person: \_\_\_\_\_

Phone: \_\_\_\_\_

Email: \_\_\_\_\_

### Questionnaire for geared motor selection

#### Gearbox type

- BM  
Electric overhead  
conveyors



Number of items: \_\_\_\_\_

Country of operation: \_\_\_\_\_

#### Trolley construction

**Trolley construction**       1/2       2/2       1/4       2/4       Sonder

Dimensions	X	[mm]	Y	[mm]	Z	[mm]
	A	[mm]	A1	[mm]	A2	[mm]

#### Operating Conditions

Installation height (above sea level)	_____ [m]	min	_____ [°C]	max	_____ [°C]
--	-----------	-----	------------	-----	------------

Mains voltage	_____ [V]	Mains frequency	_____ [Hz]
---------------	-----------	-----------------	------------

Regulations \_\_\_\_\_

Further information \_\_\_\_\_

#### Technical data - drive

Trolley mass	_____ [kg]	Suspension gear mass	_____ [kg]
Gear motor mass	_____ [kg]	Transport load mass	_____ [kg]
Wheel load of the driving wheel	_____ [N]		
Radial force on the main shaft	_____ [N]	Distance from shaft collar of...	_____ [mm]
Axial force on the main shaft	_____ [N]	Bogie wheel diameter d	_____ [mm]
Bogie wheel material	_____ [---]	Minimum curve radius	_____ [m]
Angle of the sharpest curve	_____ [°]	Total track length	_____ [m]

#### Horizontal travel

Travel velocity	max	_____ [m/min]	Duty cycle	_____ [%]
Number of start-ups per hour		_____ [---]		
Travel velocity	min	_____ [m/min]	Duty cycle	_____ [%]
Number of start-ups per hour		_____ [---]		
Travel through curves				
Travel velocity	max	_____ [m/min]	Duty cycle	_____ [%]
Number of start-ups per hour		_____ [---]		
Travel velocity (curve)	min	_____ [m/min]	Duty cycle	_____ [%]
Number of start-ups per hour		_____ [---]		
Desired acceleration		_____ [m/s <sup>2</sup> ]	Desired deceleration	_____ [m/s <sup>2</sup> ]
Permissible braking distance during operation		_____ [mm]	Requisite stopping accuracy	_____ [mm]
Permissible braking distance for emergency stop		_____ [mm]	Number of start-ups per hour	_____ [---]
Coupling		<input type="checkbox"/> manual coupling	<input type="checkbox"/> mechanical coupling	
Coupling and uncoupling possible while loaded		<input type="checkbox"/> YES	<input type="checkbox"/> NO	

4



# Gear Motor Selection

## Selection of geared motors

◀ <b>Technical data - ascent</b>			
Ascent	[°]	Length of inclined track	[m]
Travel velocity	[m/min]	Duty cycle	[%]
Number of start-ups per hour	[-]	Desired acceleration	[m/s <sup>2</sup> ]
Desired deceleration	[m/s <sup>2</sup> ]	Permissible braking distance during operation	[mm]
Requisite stopping accuracy	[mm]	Permissible braking distance for emergency stop	[mm]
Number of start-ups per hour	[-]	Ascent assistance available	<input type="checkbox"/> YES <input type="checkbox"/> NO
Surface pressure	[N]		
<b>Technical data - descent</b>			
Descent	[°]	Length of declined track	[m]
Travel velocity	[m/min]	Duty cycle	[%]
Number of start-ups per hour	[-]	Desired acceleration	[-]
Desired deceleration	[m/s <sup>2</sup> ]	Permissible braking distance during operation	[mm]
Requisite stopping accuracy	[mm]	Permissible braking distance during emergency stop	[mm]
Number of start-ups per hour	[-]	Ascent assistance available	<input type="checkbox"/> YES <input type="checkbox"/> NO
Surface pressure	[N]		
<b>Further drive versions</b>			
Mechanical brakes	<input type="checkbox"/> YES <input type="checkbox"/> NO		
Manual release	<input type="checkbox"/> YES <input type="checkbox"/> NO		
Brake supply voltage	[V]		
Brake rectifier	<input type="checkbox"/> on trolley control panel <input type="checkbox"/> in terminal box		
Brake switching	<input type="checkbox"/> AC <input type="checkbox"/> DC	Motor protection	<input type="checkbox"/> PTC <input type="checkbox"/> thermostat
Motor connection	<input type="checkbox"/> terminal box <input type="checkbox"/> connector		
<b>Main shaft</b>			
Dimensions	dlx	[mm]	Model <input type="checkbox"/> with keyway <input type="checkbox"/> without keyway
Construction		[-]	Terminal box position    [-]
RAL tone paint (Bauer-Standard RAL 7031)		[-]	

# Energy Efficient Geared Motors

## Electric overhead conveyors series BM

---

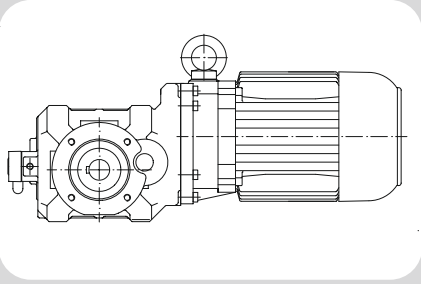

# 5

### Gearboxes & Lubrication

<b>Geared motor selection .....</b>	<b>41</b>
Standard fitting position of BM geared motors.....	41
Position of the terminal box and the cable glands.....	41
<b>Lubricants .....</b>	<b>42</b>
Lubricants .....	42
Lubricant quantities .....	43
Lubricant quantities, BM-series gears .....	44
Lubricant quantity the primary stage (Z) for installation type H1 .....	45
Gear ventilation .....	45
<b>Threaded plugs .....</b>	<b>46</b>
Position of threaded plugs	
- BM-series gears .....	46
- pre-stage gears (Z).....	47
- in the System Cover Design with Standard Geared Motor.....	48

# Energy Efficient Geared Motors

## Electric overhead conveyors series BM

---

5

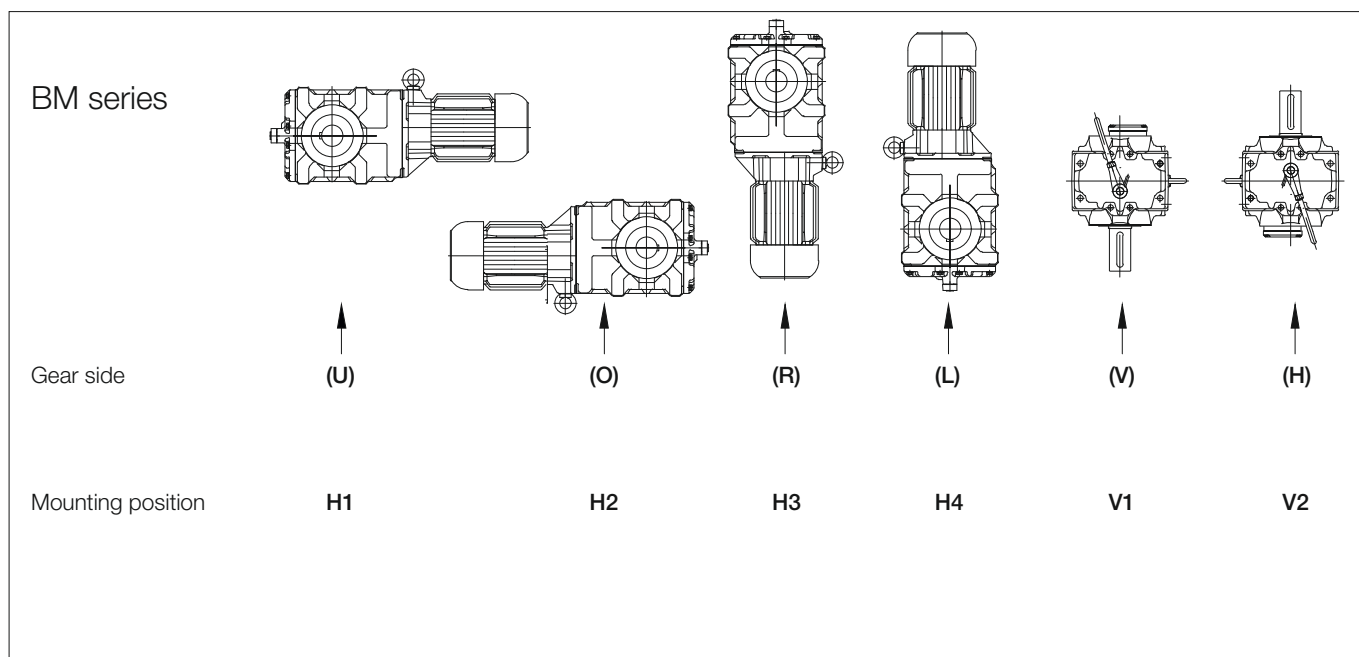

### Standard fitting position of BM geared motors

Geared motor carriages for overhead conveyors are almost always installed horizontally in installation type H1. The lubricant quantity is adapted to suit the resulting inclined positions of the gear unit where ascents and descents have to be negotiated. Please therefore specify the rise angle with your enquiries or orders. BM-series geared motors can also **be used as** point operating gears. Please indicate the mounting orientation. This usually differs from the fitting position of the carriage drives.

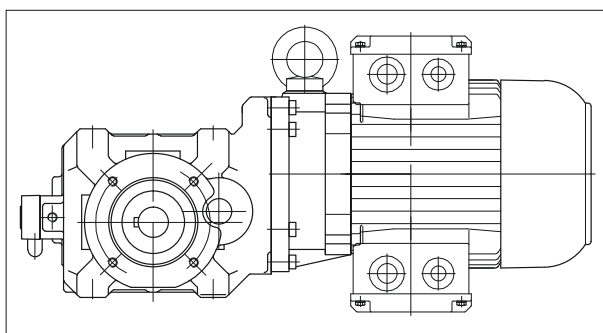

### Position of the terminal box and the cable glands

The standard position of the terminal box for BM geared motors is position III, opposite the output shaft pointing towards the "H" side of the gear unit. This position is preferred for most overhead conveyor applications. The terminal box can be supplied rotated by 90 degrees about the motor axis upon request. The standard cable entry is from side A or C. Cable entry towards the fan cowl (B) available on request.

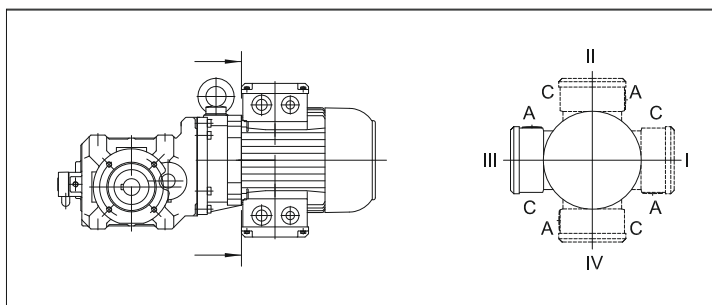

# Gearboxes & Lubrication

## Lubricants

### Lubricants

The drives are shipped ready-filled with gear lubricant. Lubricated in this way, the gear units are suitable for ambient temperatures in the range -20 °C to + 40 °C. The quantity of lubricant is optimised for the desired installed position as is stated on the nameplate. The type of lubricant is stated in the Operating Instructions. Lubricants for other temperature ranges or special applications available on request.

Wear-protective EP gear oils as indicated in the following table have proven particularly effective:

Lubricant Manufacturer	Lubricant type
	<b>Synthetic Oil</b> ISO VG 460 Standard oil for gearboxes in the series  <b>BM20-BM40</b> High temperature oil for gearboxes  <b>BM20-BM40</b>
AGIP	BLASIA S 460 [13 02 06]
BECHEM RHUS	BERUSYNTH EP 460 [13 02 06]
CASTROL	ALPHASYN PG 460 [13 02 06] OPTIGEAR 800/460 [13 02 06] OPTIGEAR 1300/460 [13 02 06] ALPHASYN GS 460 [13 02 06]
CHEVRON	Meropa Synlube WS 460 [13 02 06]
FUCHS	RENOLIN PG 460 [13 02 06]
KLÜBER	KLÜBERSYNTH GH 6-460 [13 02 06]
MOBIL	MOBIL SHC Gear 460 [13 02 06] MOBIL SHC 634*** [13 02 06]
OEST	—
SHELL	OMALA S4 WE 460 [13 02 06]
TOTAL	CARTER SY 460 [13 02 06]
WINTERSHALL	—

[...] European Waste Catalogue Code (Decision 2001/118/CE)

### Important:

Synthetic gear oils of a Polyglykol base (e.g. PGLP...) must be disposed of separately to mineral oil as **Special Waste**.

So long as the ambient temperature does not fall below  $-20\text{ °C}$  the international definition of the viscosity class at  $40\text{ °C}$  according to ISO 3448 and DIN 51519 ISO the viscosity class VG220 (SAE90) is recommended according, in North America AGMA 5EP.

For lower temperatures it is recommended to use oils of a lower nominal viscosity with a corresponding better starting characteristic, for instance a PGLP with a nominal viscosity VG68 (SAE80) or AGMA 2EP respectively. These types of oil can already be necessary at a temperature around the freezing point, if the break away torque of a drive is reduced by some smooth starting device or if the motor has a relatively low power.

### Lubricant quantities

The preferred quantity of lubricant for the planned type of installation is stated on the motor's rating plate (symbol "oil can" ). When topping up care should be taken to ensure that, depending on the fitting position, gearwheels and rolling contact bearings positioned at the top are also properly oiled. In special versions the oil level mark should be noted. Information about the quantity of lubricant required for other types of installation can be obtained from the factory.

# Gearboxes & Lubrication

## Lubricants

### Lubricant quantities, BM-series gears

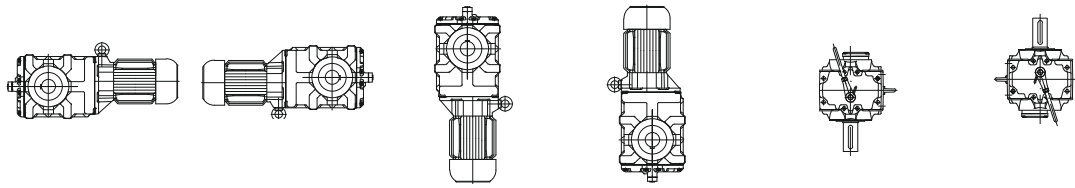

Gear type	H1	H2	H3	H4	V1	V2
BM09	0,5					
BM10	0,65					
BM20	0,7					
BM30	1,2					
	1,8*					
BM30/S1	1,2					
	1,8*					
BM30/S2	1,3					
	1,9*					
BM40	2,5					
	3,2*					
BM40/S1	2,5					
	3,2*					
BM40/S2	2,6					
	3,3*					

**on request**

\*: with BM30Z/BM40Z the prepress lubricant is filled via the main gearbox.

Lubrication quantity in litre

5



### Lubricant quantity the primary stage (Z) for installation type H1

Gear unit	Litres in the primary stage (Z)
BM09(X)	-
BM10(X)	-
BM20(X)	0,15
BM30(X)	-
BM40(X)	-
BM30Z(X)	0,2
BM40Z(X)	0,32

Lubricant quantities for other types of installation available on request.

### Gear ventilation

BM gear units are shipped ready-equipped with a vent plug. Low operating temperatures are achieved thanks to the high levels of efficiency of BM gear units and the fact that their surfaces have been designed for optimum heat dissipation. This results in oil change intervals of 2500.

# Gearboxes & Lubrication

## Threaded plugs

Position of threaded plugs  
- BM-series gears

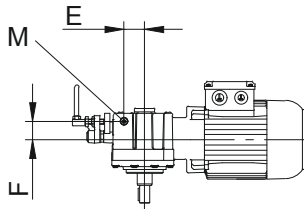
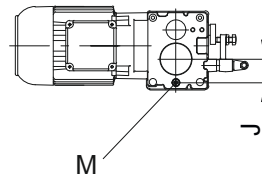
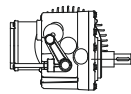
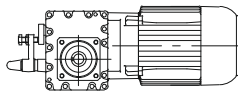

5

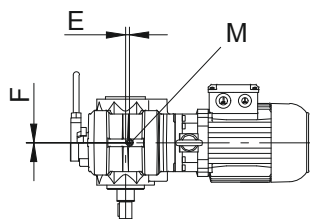
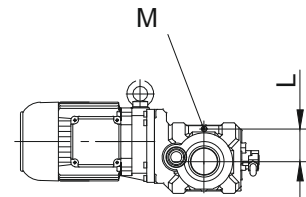
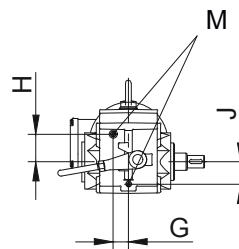
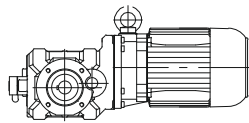
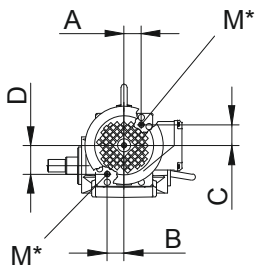

Type	A	B	C	D	E	F	G	H	J	L	M
BM09		-		B.09	41	36	-	-	46.5		M10x1
BM10		*Tab.I-Tab.III size		B.10	8	0	30	55	45	-	M10x1
BM20		*Tab.I-Tab.III size		B.20	0	49	-	-	45	62	M10x1
BM30		*Tab.I-Tab.III size		B.30	-	-	0	70	-	-	M10x1
BM40		*Tab.I-Tab.III size		B.40	-	-	0	-	-	-	-

M = Plug according to DIN 908

\* see Position of the oil drain and filler plugs on the system cover

Dimensions in millimetres (mm)

M\* =Factor and position of the drain plug see page 48.

### Position of threaded plugs - pre-stage gears (Z)

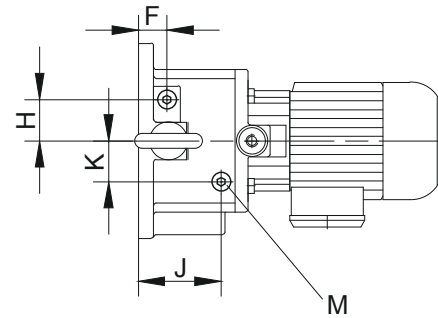
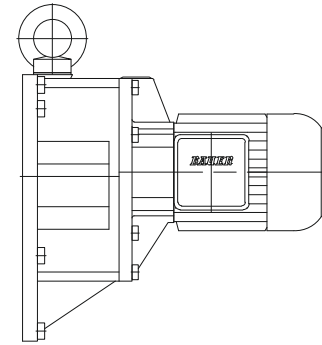
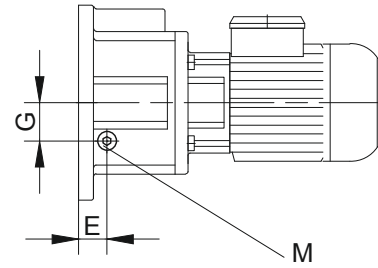
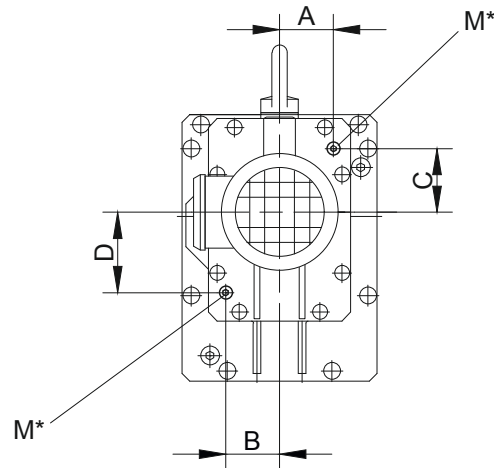

5

Type	A	B	C	D	E	F	G	H	J	K	M
BM20(Z)	-	-	-	-	49	-	28.5	-	23.5	28	M10x1
BM30(Z)	*Tab.I-Tab.III size B.10				-	24	-	30	-	-	M10x1
BM40(Z)	*Tab.I-Tab.III size B.10				-	27.5	-	36.5	-	-	M14x1.5

M = Plug according to DIN 908  
 \* see Position of the oil drain and filler plugs on the system cover  
 Dimensions in millimetres (mm)

M\* =Factor and position of the drain plug see page 48.

# Gearboxes & Lubrication

## Threaded plugs

Position of the drain plugs  
- in the System Cover Design with Standard Geared Motor

5

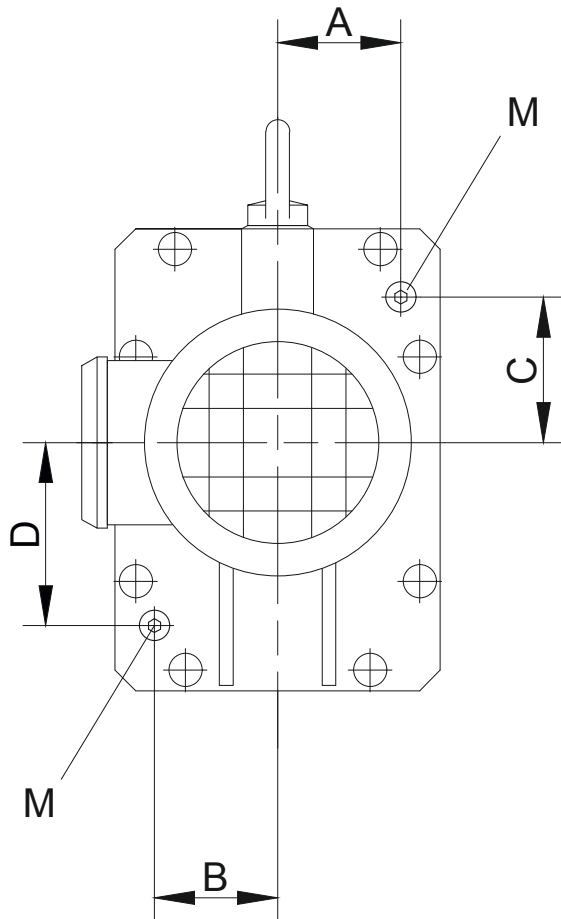
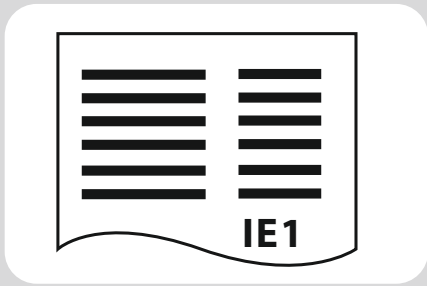

Table I: Design with Standard Geared Motor

Gear	Size	A	B	C	D	M
BM10(X)	D05-D..09	36	34	43.5	59	M10x1
BM20(X)	D05-D..09	44	44	58	72,5	M10x1
BM30(X)	D05-D..09	56.5	40	58.2	75	M10x1
BM40(X)	D08-D..11	66	71	71	94	M14x1.5

M = Plug according to DIN 908  
Dimensions in millimetres (mm)



# 6

### Selection tables ASM-IE1

Selection table asynchronous motors ASM IE1 .....	51
---	----

# Energy Efficient Geared Motors

## Electric overhead conveyors series BM

---

# Geared motors for electric overhead conveyors series BM

## Selection table asynchronous motors ASM IE1

### 0.03 kW

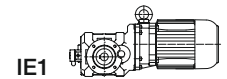

P <sub>N</sub> [kW]	50 Hz			i [:1]	Type	m [kg]	F <sub>RN</sub> [N]	F <sub>RV</sub> [N]
	n <sub>2</sub> [1/min]	M <sub>2</sub> [Nm]	f <sub>B</sub> [—]					
0.03	16.5	15.4	10	82.54	BM10G06-../D04LA4	23	8000	10000
0.03	15	17.3	8.7	90.78	BM10G06-../D04LA4	23	8000	10000
0.03	13.5	18.6	8.1	102.7	BM10G06-../D04LA4	23	8000	10000
0.03	11.5	21.5	7.0	120.5	BM10G06-../D04LA4	23	8000	10000
0.03	10.5	24	6.7	133.7	BM10G06-../D04LA4	23	8000	10000
0.03	9.0	27	5.6	150.7	BM10G06-../D04LA4	23	8000	10000
0.03	8.1	30	5.3	167.2	BM10G06-../D04LA4	23	8000	10000
0.03	7.2	35	4.3	189.8	BM10G06-../D04LA4	23	8000	10000
0.03	6.2	39.5	4.1	219.4	BM10G06-../D04LA4	23	8000	10000
0.03	5.3	46	3.5	258.1	BM10G06-../D04LA4	23	8000	10000
0.03	4.4	55	2.9	308.9	BM10G06-../D04LA4	23	8000	10000
0.03	4.0	61	2.6	345.4	BM10G06-../D04LA4	23	8000	10000
0.03	3.6	68	2.4	377.0	BM10G06-../D04LA4	23	8000	10000
0.03	3.3	74	2.2	415.3	BM10G06-../D04LA4	23	8000	10000
0.03	3.0	82	1.95	452.9	BM10G06-../D04LA4	23	8000	10000
0.03	2.5	98	1.65	544.2	BM10G06-../D04LA4	23	8000	10000
0.03	2.3	107	1.5	593.9	BM10G06-../D04LA4	23	8000	10000
0.03	2.0	123	1.3	698.8	BM10G06-../D04LA4	23	8000	10000
0.03	1.7	144	1.1	836.2	BM10G06-../D04LA4	23	8000	10000
0.03	1.5	164	0.98	938.2	BM10G06-../D04LA4	23	8000	10000
0.03	1.2	160*	1.0	1186	BM10G06-../D04LA4	23	8000	10000
0.03	0.95	160*	1.0	1482	BM10G06-../D04LA4	23	8000	10000
0.03	0.8	160*	1.0	1701	BM10G06-../D04LA4	23	8000	10000
0.03	0.7	160*	1.0	1935	BM10G06-../D04LA4	23	8000	10000
0.03	0.65	160*	1.0	2111	BM10G06-../D04LA4	23	8000	10000
0.03	0.6	160*	1.0	2254	BM10G06-../D04LA4	23	8000	10000
0.03	0.55	160*	1.0	2459	BM10G06-../D04LA4	23	8000	10000
0.03	2.1	122	2.9	663.4	BM30G06-../D04LA4	44	12000	15000
0.03	1.8	143	2.4	780.6	BM30G06-../D04LA4	44	12000	15000
0.03	1.5	171	2.0	934.1	BM30G06-../D04LA4	44	12000	15000
0.03	1.2	210	1.65	1143	BM30G06-../D04LA4	44	12000	15000
0.03	1.1	230	1.5	1325	BM30G06-../D04LA4	44	12000	15000
0.03	0.9	285	1.25	1518	BM30G06-../D04LA4	44	12000	15000
0.03	0.85	300	1.15	1656	BM30G06-../D04LA4	44	12000	15000
0.03	0.75	340	1.05	1900	BM30G06-../D04LA4	44	12000	15000
0.03	0.65	350*	1.0	2162	BM30G06-../D04LA4	44	12000	15000
0.03	0.6	350*	1.0	2358	BM30G06-../D04LA4	44	12000	15000
0.03	0.5	350*	1.0	2747	BM30G06-../D04LA4	44	12000	15000

6

### 0.04 kW

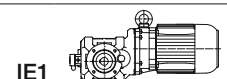

P <sub>N</sub> [kW]	50 Hz			i [:1]	Type	m [kg]	F <sub>RN</sub> [N]	F <sub>RV</sub> [N]
	n <sub>2</sub> [1/min]	M <sub>2</sub> [Nm]	f <sub>B</sub> [—]					
0.04	25.5	13.6	10	53.03	BM10G06-../D04LA4	23	8000	10000
0.04	23	15.1	9.9	58.79	BM10G06-../D04LA4	23	8000	10000
0.04	19.5	17.8	7.9	69.61	BM10G06-../D04LA4	23	8000	10000
0.04	18.5	18.3	7.9	74.41	BM10G06-../D04LA4	23	8000	10000
0.04	16.5	20.5	7.6	82.54	BM10G06-../D04LA4	23	8000	10000
0.04	15	23	6.5	90.78	BM10G06-../D04LA4	23	8000	10000
0.04	13.5	24.5	6.1	102.7	BM10G06-../D04LA4	23	8000	10000
0.04	11.5	29	5.2	120.5	BM10G06-../D04LA4	23	8000	10000
0.04	10.5	32	5.0	133.7	BM10G06-../D04LA4	23	8000	10000
0.04	9.0	36.5	4.1	150.7	BM10G06-../D04LA4	23	8000	10000
0.04	8.1	40.5	4.0	167.2	BM10G06-../D04LA4	23	8000	10000
0.04	7.2	46.5	3.2	189.8	BM10G06-../D04LA4	23	8000	10000
0.04	6.2	52	3.1	219.4	BM10G06-../D04LA4	23	8000	10000
0.04	5.3	61	2.6	258.1	BM10G06-../D04LA4	23	8000	10000
0.04	4.4	74	2.2	308.9	BM10G06-../D04LA4	23	8000	10000
0.04	4.0	82	1.95	345.4	BM10G06-../D04LA4	23	8000	10000
0.04	3.6	91	1.75	377.0	BM10G06-../D04LA4	23	8000	10000
0.04	3.3	99	1.6	415.3	BM10G06-../D04LA4	23	8000	10000
0.04	3.0	109	1.45	452.9	BM10G06-../D04LA4	23	8000	10000
0.04	2.5	131	1.2	544.2	BM10G06-../D04LA4	23	8000	10000
0.04	2.3	142	1.15	593.9	BM10G06-../D04LA4	23	8000	10000
0.04	2.0	164	0.98	698.8	BM10G06-../D04LA4	23	8000	10000
0.04	1.7	193	0.83	836.2	BM10G06-../D04LA4	23	8000	10000

# Geared motors for electric overhead conveyors series BM

## Selection table asynchronous motors ASM IE1

### 0.04 kW

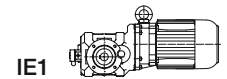

P <sub>N</sub> [kW]	50 Hz			i [:1]	Type	m [kg]	F <sub>RN</sub> [N]	F <sub>RV</sub> [N]
	n <sub>2</sub> [1/min]	M <sub>2</sub> [Nm]	f <sub>B</sub> [-]					
0.04	5.4	67	2.7	253.0	BM20Z-../D04LA4	21	12000	12000
0.04	3.0	114	3.1	463.9	BM30G06-../D04LA4	44	12000	15000
0.04	2.6	132	2.7	533.9	BM30G06-../D04LA4	44	12000	15000
0.04	2.1	163	2.1	663.4	BM30G06-../D04LA4	44	12000	15000
0.04	1.8	191	1.85	780.6	BM30G06-../D04LA4	44	12000	15000
0.04	1.5	225	1.55	934.1	BM30G06-../D04LA4	44	12000	15000
0.04	1.2	285	1.25	1143	BM30G06-../D04LA4	44	12000	15000
0.04	1.1	310	1.15	1325	BM30G06-../D04LA4	44	12000	15000

### 0.06 kW

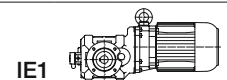

P <sub>N</sub> [kW]	50 Hz			i [:1]	Type	m [kg]	F <sub>RN</sub> [N]	F <sub>RV</sub> [N]
	n <sub>2</sub> [1/min]	M <sub>2</sub> [Nm]	f <sub>B</sub> [-]					
0.06	33.5	14.3	10	40.56	BM10-../D06LA4	21	8000	10000
0.06	30	16	10	45.00	BM10-../D06LA4	21	8000	10000
0.06	26	18	8.3	52.44	BM10-../D06LA4	21	8000	10000
0.06	23.5	19.9	8.0	58.18	BM10-../D06LA4	21	8000	10000
0.06	10.5	48	3.3	133.7	BM10G06-../D06LA4	26	8000	10000
0.06	9.0	54	2.8	150.7	BM10G06-../D06LA4	26	8000	10000
0.06	8.1	60	2.7	167.2	BM10G06-../D06LA4	26	8000	10000
0.06	7.2	70	2.1	189.8	BM10G06-../D06LA4	26	8000	10000
0.06	6.2	79	2.0	219.4	BM10G06-../D06LA4	26	8000	10000
0.06	5.3	92	1.75	258.1	BM10G06-../D06LA4	26	8000	10000
0.06	4.4	111	1.45	308.9	BM10G06-../D06LA4	26	8000	10000
0.06	4.0	123	1.3	345.4	BM10G06-../D06LA4	26	8000	10000
0.06	3.6	136	1.2	377.0	BM10G06-../D06LA4	26	8000	10000
0.06	3.3	149	1.05	415.3	BM10G06-../D06LA4	26	8000	10000
0.06	3.0	164	0.98	452.9	BM10G06-../D06LA4	26	8000	10000
0.06	2.5	197	0.81	544.2	BM10G06-../D06LA4	26	8000	10000
0.06	7.6	71	2.9	178.9	BM20Z-../D06LA4	24	12000	12000
0.06	6.6	82	2.4	205.3	BM20Z-../D06LA4	24	12000	12000
0.06	5.4	100	1.8	253.0	BM20Z-../D06LA4	24	12000	12000
0.06	4.7	109	3.2	288.3	BM30G06-../D06LA4	47	12000	15000
0.06	4.0	128	2.7	345.1	BM30G06-../D06LA4	47	12000	15000
0.06	3.5	147	2.4	385.8	BM30G06-../D06LA4	47	12000	15000
0.06	3.0	171	2.0	463.9	BM30G06-../D06LA4	47	12000	15000
0.06	2.6	198	1.75	533.9	BM30G06-../D06LA4	47	12000	15000
0.06	2.1	245	1.45	663.4	BM30G06-../D06LA4	47	12000	15000
0.06	1.8	285	1.25	780.6	BM30G06-../D06LA4	47	12000	15000
0.06	1.5	340	1.05	934.1	BM30G06-../D06LA4	47	12000	15000
0.06	1.2	425	0.82	1143	BM30G06-../D06LA4	47	12000	15000
0.06	2.5	205	3.3	540.0	BM40G10-../D06LA4	68	20000	25000
0.06	2.1	245	2.8	660.2	BM40G10-../D06LA4	68	20000	25000
0.06	1.8	285	2.4	756.7	BM40G10-../D06LA4	68	20000	25000
0.06	1.7	300	2.3	838.4	BM40G10-../D06LA4	68	20000	25000
0.06	1.4	365	1.85	998.3	BM40G10-../D06LA4	68	20000	25000
0.06	1.2	425	1.6	1189	BM40G10-../D06LA4	68	20000	25000
0.06	0.95	540	1.25	1428	BM40G10-../D06LA4	68	20000	25000
0.06	0.8	640	1.05	1798	BM40G10-../D06LA4	68	20000	25000

### 0.09 kW

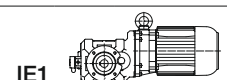

P <sub>N</sub> [kW]	50 Hz			i [:1]	Type	m [kg]	F <sub>RN</sub> [N]	F <sub>RV</sub> [N]
	n <sub>2</sub> [1/min]	M <sub>2</sub> [Nm]	f <sub>B</sub> [-]					
0.09	51	14.8	10	26.55	BM10-../D06LA4	21	8000	10000
0.09	46	16.4	9.8	29.45	BM10-../D06LA4	21	8000	10000
0.09	41	18	8.3	33.19	BM10-../D06LA4	21	8000	10000
0.09	37	19.9	8.0	36.82	BM10-../D06LA4	21	8000	10000
0.09	33.5	21.5	7.0	40.56	BM10-../D06LA4	21	8000	10000



# Geared motors for electric overhead conveyors series BM

## Selection table asynchronous motors ASM IE1

### 0.09 kW

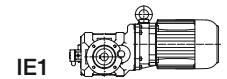

P <sub>N</sub> [kW]	50 Hz			i [:1]	Type	m [kg]	F <sub>RN</sub> [N]	F <sub>RV</sub> [N]
	n <sub>2</sub> [1/min]	M <sub>2</sub> [Nm]	f <sub>B</sub> [—]					
0.09	30	24	6.7	45.00	BM10-../D06LA4	21	8000	10000
0.09	26	27	5.6	52.44	BM10-../D06LA4	21	8000	10000
0.09	23.5	29.5	5.4	58.18	BM10-../D06LA4	21	8000	10000
0.09	15	52	2.9	90.78	BM10G06-../D06LA4	26	8000	10000
0.09	13.5	56	2.7	102.7	BM10G06-../D06LA4	26	8000	10000
0.09	11.5	65	2.3	120.5	BM10G06-../D06LA4	26	8000	10000
0.09	10.5	72	2.2	133.7	BM10G06-../D06LA4	26	8000	10000
0.09	9.0	82	1.85	150.7	BM10G06-../D06LA4	26	8000	10000
0.09	8.1	91	1.75	167.2	BM10G06-../D06LA4	26	8000	10000
0.09	7.2	105	1.45	189.8	BM10G06-../D06LA4	26	8000	10000
0.09	6.2	119	1.35	219.4	BM10G06-../D06LA4	26	8000	10000
0.09	5.3	139	1.15	258.1	BM10G06-../D06LA4	26	8000	10000
0.09	4.4	167	0.96	308.9	BM10G06-../D06LA4	26	8000	10000
0.09	4.0	184	0.87	345.4	BM10G06-../D06LA4	26	8000	10000
0.09	11.5	71	3.1	117.9	BM20Z-../D06LA4	24	12000	12000
0.09	9.5	85	2.6	142.8	BM20Z-../D06LA4	24	12000	12000
0.09	7.6	107	1.95	178.9	BM20Z-../D06LA4	24	12000	12000
0.09	6.6	123	1.55	205.3	BM20Z-../D06LA4	24	12000	12000
0.09	5.4	151	1.2	253.0	BM20Z-../D06LA4	24	12000	12000
0.09	7.3	105	3.3	186.7	BM30G06-../D06LA4	47	12000	15000
0.09	6.5	120	2.9	208.6	BM30G06-../D06LA4	47	12000	15000
0.09	5.6	138	2.5	245.1	BM30G06-../D06LA4	47	12000	15000
0.09	4.7	164	2.1	288.3	BM30G06-../D06LA4	47	12000	15000
0.09	4.0	193	1.8	345.1	BM30G06-../D06LA4	47	12000	15000
0.09	3.5	220	1.6	385.8	BM30G06-../D06LA4	47	12000	15000
0.09	3.0	255	1.35	463.9	BM30G06-../D06LA4	47	12000	15000
0.09	2.6	295	1.2	533.9	BM30G06-../D06LA4	47	12000	15000
0.09	2.1	365	0.96	663.4	BM30G06-../D06LA4	47	12000	15000
0.09	1.8	425	0.82	780.6	BM30G06-../D06LA4	47	12000	15000
0.09	3.9	178	2.8	348.7	BM40Z-../D06LA4	64	20000	25000
0.09	3.2	210	2.4	430.0	BM40Z-../D06LA4	64	20000	25000
0.09	2.8	275	2.5	487.3	BM40G10-../D06LA4	68	20000	25000
0.09	2.5	305	2.2	540.0	BM40G10-../D06LA4	68	20000	25000
0.09	2.1	365	1.85	660.2	BM40G10-../D06LA4	68	20000	25000
0.09	1.8	425	1.6	756.7	BM40G10-../D06LA4	68	20000	25000
0.09	1.7	455	1.5	838.4	BM40G10-../D06LA4	68	20000	25000
0.09	1.4	550	1.25	998.3	BM40G10-../D06LA4	68	20000	25000
0.09	1.2	640	1.05	1189	BM40G10-../D06LA4	68	20000	25000

6

### 0.11 kW

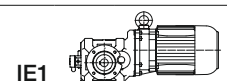

P <sub>N</sub> [kW]	50 Hz			i [:1]	Type	m [kg]	F <sub>RN</sub> [N]	F <sub>RV</sub> [N]
	n <sub>2</sub> [1/min]	M <sub>2</sub> [Nm]	f <sub>B</sub> [—]					
0.11	31	30.5	4.6	44.15	BM10G06-../D04LA4	23	8000	10000
0.11	25.5	37	3.8	53.03	BM10G06-../D04LA4	23	8000	10000
0.11	23	41.5	3.6	58.79	BM10G06-../D04LA4	23	8000	10000
0.11	19.5	49	2.9	69.61	BM10G06-../D04LA4	23	8000	10000
0.11	18.5	50	2.9	74.41	BM10G06-../D04LA4	23	8000	10000
0.11	16.5	56	2.8	82.54	BM10G06-../D04LA4	23	8000	10000
0.11	15	63	2.4	90.78	BM10G06-../D04LA4	23	8000	10000
0.11	13.5	68	2.2	102.7	BM10G06-../D04LA4	23	8000	10000
0.11	11.5	80	1.9	120.5	BM10G06-../D04LA4	23	8000	10000
0.11	10.5	88	1.8	133.7	BM10G06-../D04LA4	23	8000	10000
0.11	9.0	100	1.5	150.7	BM10G06-../D04LA4	23	8000	10000
0.11	8.1	111	1.45	167.2	BM10G06-../D04LA4	23	8000	10000
0.11	7.2	128	1.15	189.8	BM10G06-../D04LA4	23	8000	10000
0.11	6.2	145	1.1	219.4	BM10G06-../D04LA4	23	8000	10000
0.11	5.3	170	0.94	258.1	BM10G06-../D04LA4	23	8000	10000
0.11	4.4	160*	1.0	308.9	BM10G06-../D04LA4	23	8000	10000
0.11	4.0	160*	1.0	345.4	BM10G06-../D04LA4	23	8000	10000
0.11	3.6	160*	1.0	377.0	BM10G06-../D04LA4	23	8000	10000
0.11	3.3	160*	1.0	415.3	BM10G06-../D04LA4	23	8000	10000
0.11	3.0	160*	1.0	452.9	BM10G06-../D04LA4	23	8000	10000
0.11	2.5	160*	1.0	544.2	BM10G06-../D04LA4	23	8000	10000

# Geared motors for electric overhead conveyors series BM

## Selection table asynchronous motors ASM IE1

### 0.11 kW

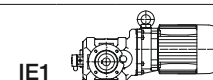

P <sub>N</sub> [kW]	50 Hz			i [:1]	Type	m [kg]	F <sub>RN</sub> [N]	F <sub>RV</sub> [N]
	n <sub>2</sub> [1/min]	M <sub>2</sub> [Nm]	f <sub>B</sub> [—]					
0.11	2.3	160*	1.0	593.9	BM10G06-../D04LA4	23	8000	10000
0.11	2.0	160*	1.0	698.8	BM10G06-../D04LA4	23	8000	10000
0.11	1.7	160*	1.0	836.2	BM10G06-../D04LA4	23	8000	10000
0.11	1.5	160*	1.0	938.2	BM10G06-../D04LA4	23	8000	10000
0.11	1.2	160*	1.0	1186	BM10G06-../D04LA4	23	8000	10000
0.11	0.95	160*	1.0	1482	BM10G06-../D04LA4	23	8000	10000
0.11	0.8	160*	1.0	1701	BM10G06-../D04LA4	23	8000	10000
0.11	0.7	160*	1.0	1935	BM10G06-../D04LA4	23	8000	10000
0.11	0.65	160*	1.0	2111	BM10G06-../D04LA4	23	8000	10000
0.11	0.6	160*	1.0	2254	BM10G06-../D04LA4	23	8000	10000
0.11	0.55	160*	1.0	2459	BM10G06-../D04LA4	23	8000	10000
0.11	14	71	3.1	99.47	BM20Z-../D04LA4	21	12000	12000
0.11	11.5	86	2.6	117.9	BM20Z-../D04LA4	21	12000	12000
0.11	9.5	105	2.1	142.8	BM20Z-../D04LA4	21	12000	12000
0.11	7.6	131	1.6	178.9	BM20Z-../D04LA4	21	12000	12000
0.11	6.6	151	1.3	205.3	BM20Z-../D04LA4	21	12000	12000
0.11	5.4	184	0.99	253.0	BM20Z-../D04LA4	21	12000	12000
0.11	7.3	129	2.7	186.7	BM30G06-../D04LA4	44	12000	15000
0.11	6.5	147	2.4	208.6	BM30G06-../D04LA4	44	12000	15000
0.11	5.6	168	2.1	245.1	BM30G06-../D04LA4	44	12000	15000
0.11	4.7	200	1.75	288.3	BM30G06-../D04LA4	44	12000	15000
0.11	4.0	235	1.5	345.1	BM30G06-../D04LA4	44	12000	15000
0.11	3.5	270	1.3	385.8	BM30G06-../D04LA4	44	12000	15000
0.11	3.0	315	1.1	463.9	BM30G06-../D04LA4	44	12000	15000
0.11	2.6	360	0.97	533.9	BM30G06-../D04LA4	44	12000	15000
0.11	2.1	350*	1.0	663.4	BM30G06-../D04LA4	44	12000	15000
0.11	1.8	350*	1.0	780.6	BM30G06-../D04LA4	44	12000	15000
0.11	1.5	350*	1.0	934.1	BM30G06-../D04LA4	44	12000	15000
0.11	1.2	350*	1.0	1143	BM30G06-../D04LA4	44	12000	15000
0.11	1.1	350*	1.0	1325	BM30G06-../D04LA4	44	12000	15000
0.11	0.9	350*	1.0	1518	BM30G06-../D04LA4	44	12000	15000
0.11	0.85	350*	1.0	1656	BM30G06-../D04LA4	44	12000	15000
0.11	0.75	350*	1.0	1900	BM30G06-../D04LA4	44	12000	15000
0.11	0.65	350*	1.0	2162	BM30G06-../D04LA4	44	12000	15000
0.11	0.6	350*	1.0	2358	BM30G06-../D04LA4	44	12000	15000
0.11	0.5	350*	1.0	2747	BM30G06-../D04LA4	44	12000	15000

### 0.12 kW

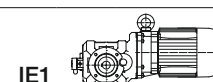

P <sub>N</sub> [kW]	50 Hz			i [:1]	Type	m [kg]	F <sub>RN</sub> [N]	F <sub>RV</sub> [N]
	n <sub>2</sub> [1/min]	M <sub>2</sub> [Nm]	f <sub>B</sub> [—]					
0.12	31	33.5	4.2	44.15	BM10G06-../DSE04LA4	23	8000	10000
0.12	25.5	40.5	3.5	53.03	BM10G06-../DSE04LA4	23	8000	10000
0.12	23	45	3.3	58.79	BM10G06-../DSE04LA4	23	8000	10000
0.12	19.5	53	2.6	69.61	BM10G06-../DSE04LA4	23	8000	10000
0.12	18.5	55	2.6	74.41	BM10G06-../DSE04LA4	23	8000	10000
0.12	16.5	61	2.5	82.54	BM10G06-../DSE04LA4	23	8000	10000
0.12	15	69	2.2	90.78	BM10G06-../DSE04LA4	23	8000	10000
0.12	13.5	74	2.0	102.7	BM10G06-../DSE04LA4	23	8000	10000
0.12	11.5	87	1.7	120.5	BM10G06-../DSE04LA4	23	8000	10000
0.12	10.5	96	1.65	133.7	BM10G06-../DSE04LA4	23	8000	10000
0.12	9.0	109	1.4	150.7	BM10G06-../DSE04LA4	23	8000	10000
0.12	8.1	121	1.3	167.2	BM10G06-../DSE04LA4	23	8000	10000
0.12	7.2	140	1.05	189.8	BM10G06-../DSE04LA4	23	8000	10000
0.12	6.2	158	1.0	219.4	BM10G06-../DSE04LA4	23	8000	10000
0.12	5.3	185	0.86	258.1	BM10G06-../DSE04LA4	23	8000	10000
0.12	4.4	160*	1.0	308.9	BM10G06-../DSE04LA4	23	8000	10000
0.12	4.0	160*	1.0	345.4	BM10G06-../DSE04LA4	23	8000	10000
0.12	3.6	160*	1.0	377.0	BM10G06-../DSE04LA4	23	8000	10000
0.12	3.3	160*	1.0	415.3	BM10G06-../DSE04LA4	23	8000	10000
0.12	3.0	160*	1.0	452.9	BM10G06-../DSE04LA4	23	8000	10000
0.12	2.5	160*	1.0	544.2	BM10G06-../DSE04LA4	23	8000	10000
0.12	2.3	160*	1.0	593.9	BM10G06-../DSE04LA4	23	8000	10000
0.12	2.0	160*	1.0	698.8	BM10G06-../DSE04LA4	23	8000	10000
0.12	1.7	160*	1.0	836.2	BM10G06-../DSE04LA4	23	8000	10000

# Geared motors for electric overhead conveyors series BM

## Selection table asynchronous motors ASM IE1

0.12 kW

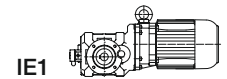

P <sub>N</sub> [kW]	50 Hz			i [·:1]	Type	m [kg]	F <sub>RN</sub> [N]	F <sub>RV</sub> [N]
	n <sub>2</sub> [1/min]	M <sub>2</sub> [Nm]	f <sub>B</sub> [—]					
0.12	1.5	160*	1.0	938.2	BM10G06-../DSE04LA4	23	8000	10000
0.12	1.2	160*	1.0	1186	BM10G06-../DSE04LA4	23	8000	10000
0.12	0.95	160*	1.0	1482	BM10G06-../DSE04LA4	23	8000	10000
0.12	0.8	160*	1.0	1701	BM10G06-../DSE04LA4	23	8000	10000
0.12	0.7	160*	1.0	1935	BM10G06-../DSE04LA4	23	8000	10000
0.12	0.65	160*	1.0	2111	BM10G06-../DSE04LA4	23	8000	10000
0.12	0.6	160*	1.0	2254	BM10G06-../DSE04LA4	23	8000	10000
0.12	0.55	160*	1.0	2459	BM10G06-../DSE04LA4	23	8000	10000
0.12	16	68	3.2	85.45	BM20Z-../DSE04LA4	21	12000	12000
0.12	14	77	2.9	99.47	BM20Z-../DSE04LA4	21	12000	12000
0.12	11.5	94	2.3	117.9	BM20Z-../DSE04LA4	21	12000	12000
0.12	9.5	114	1.95	142.8	BM20Z-../DSE04LA4	21	12000	12000
0.12	7.6	143	1.45	178.9	BM20Z-../DSE04LA4	21	12000	12000
0.12	6.6	164	1.2	205.3	BM20Z-../DSE04LA4	21	12000	12000
0.12	5.4	200	0.91	253.0	BM20Z-../DSE04LA4	21	12000	12000
0.12	7.3	141	2.5	186.7	BM30G06-../DSE04LA4	44	12000	15000
0.12	6.5	160	2.2	208.6	BM30G06-../DSE04LA4	44	12000	15000
0.12	5.6	184	1.9	245.1	BM30G06-../DSE04LA4	44	12000	15000
0.12	4.7	215	1.65	288.3	BM30G06-../DSE04LA4	44	12000	15000
0.12	4.0	255	1.35	345.1	BM30G06-../DSE04LA4	44	12000	15000
0.12	3.5	290	1.2	385.8	BM30G06-../DSE04LA4	44	12000	15000
0.12	3.0	340	1.05	463.9	BM30G06-../DSE04LA4	44	12000	15000
0.12	2.6	395	0.89	533.9	BM30G06-../DSE04LA4	44	12000	15000
0.12	2.1	350*	1.0	663.4	BM30G06-../DSE04LA4	44	12000	15000
0.12	1.8	350*	1.0	780.6	BM30G06-../DSE04LA4	44	12000	15000
0.12	1.5	350*	1.0	934.1	BM30G06-../DSE04LA4	44	12000	15000
0.12	1.2	350*	1.0	1143	BM30G06-../DSE04LA4	44	12000	15000
0.12	1.1	350*	1.0	1325	BM30G06-../DSE04LA4	44	12000	15000
0.12	0.9	350*	1.0	1518	BM30G06-../DSE04LA4	44	12000	15000
0.12	0.85	350*	1.0	1656	BM30G06-../DSE04LA4	44	12000	15000
0.12	0.75	350*	1.0	1900	BM30G06-../DSE04LA4	44	12000	15000
0.12	0.65	350*	1.0	2162	BM30G06-../DSE04LA4	44	12000	15000
0.12	0.6	350*	1.0	2358	BM30G06-../DSE04LA4	44	12000	15000
0.12	0.5	350*	1.0	2747	BM30G06-../DSE04LA4	44	12000	15000
0.12	120	12.6	2.4	11.34	BM09-../DSE05LA4	13	4400	6500
0.12	103	14.6	2.2	13.23	BM09-../DSE05LA4	13	4400	6500
0.12	77	19.6	2.4	17.73	BM09-../DSE05LA4	13	4400	6500
0.12	64	23.5	2.4	21.20	BM09-../DSE05LA4	13	4400	6500
0.12	55	27.5	2.1	24.74	BM09-../DSE05LA4	13	4400	6500
0.12	52	29	2.4	25.98	BM09-../DSE05LA4	13	4400	6500
0.12	45	33.5	2.1	30.31	BM09-../DSE05LA4	13	4400	6500
0.12	41	36.5	2.4	32.97	BM09-../DSE05LA4	13	4400	6500
0.12	35.5	42.5	2.2	38.46	BM09-../DSE05LA4	13	4400	6500
0.12	32	46.5	1.85	42.44	BM09-../DSE05LA4	13	4400	6500
0.12	25.5	58	1.85	53.85	BM09-../DSE05LA4	13	4400	6500
0.12	30	48	3.3	45.00	BM10-../DSE06LA4	21	8000	10000
0.12	26	54	2.8	52.44	BM10-../DSE06LA4	21	8000	10000
0.12	23.5	59	2.7	58.18	BM10-../DSE06LA4	21	8000	10000
0.12	23	68	2.2	58.79	BM10G06-../DSE06LA4	26	8000	10000
0.12	19.5	80	1.75	69.61	BM10G06-../DSE06LA4	26	8000	10000
0.12	18.5	82	1.75	74.41	BM10G06-../DSE06LA4	26	8000	10000
0.12	16.5	92	1.7	82.54	BM10G06-../DSE06LA4	26	8000	10000
0.12	15	104	1.45	90.78	BM10G06-../DSE06LA4	26	8000	10000
0.12	13.5	112	1.35	102.7	BM10G06-../DSE06LA4	26	8000	10000
0.12	11.5	131	1.15	120.5	BM10G06-../DSE06LA4	26	8000	10000
0.12	10.5	144	1.1	133.7	BM10G06-../DSE06LA4	26	8000	10000
0.12	9.0	164	0.91	150.7	BM10G06-../DSE06LA4	26	8000	10000
0.12	8.1	182	0.88	167.2	BM10G06-../DSE06LA4	26	8000	10000
0.12	22.5	72	2.7	60.64	BM20-../DSE06LA4	23	12000	12000
0.12	18.5	88	2.1	74.76	BM20-../DSE06LA4	23	12000	12000
0.12	16	102	2.2	85.45	BM20Z-../DSE06LA4	24	12000	12000
0.12	14	116	1.9	99.47	BM20Z-../DSE06LA4	24	12000	12000
0.12	11.5	142	1.55	117.9	BM20Z-../DSE06LA4	24	12000	12000
0.12	9.5	171	1.3	142.8	BM20Z-../DSE06LA4	24	12000	12000
0.12	7.6	210	1.0	178.9	BM20Z-../DSE06LA4	24	12000	12000

6

# Geared motors for electric overhead conveyors series BM

## Selection table asynchronous motors ASM IE1

0.12 kW

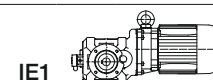

P <sub>N</sub> [kW]	50 Hz			i [:1]	Type	m [kg]	F <sub>RN</sub> [N]	F <sub>RV</sub> [N]
	n <sub>2</sub> [1/min]	M <sub>2</sub> [Nm]	f <sub>B</sub> [-]					
0.12	19	79	3.3	71.09	BM30-../DSE06LA4	39	12000	15000
0.12	13.5	109	3.2	100.7	BM30Z-../DSE06LA4	41	12000	15000
0.12	11	134	2.6	128.2	BM30Z-../DSE06LA4	41	12000	15000
0.12	9.0	162	2.2	150.3	BM30Z-../DSE06LA4	41	12000	15000
0.12	7.7	189	1.85	177.2	BM30Z-../DSE06LA4	41	12000	15000
0.12	7.3	210	1.65	186.7	BM30G06-../DSE06LA4	47	12000	15000
0.12	6.5	240	1.45	208.6	BM30G06-../DSE06LA4	47	12000	15000
0.12	5.6	275	1.25	245.1	BM30G06-../DSE06LA4	47	12000	15000
0.12	4.7	325	1.1	288.3	BM30G06-../DSE06LA4	47	12000	15000
0.12	4.0	385	0.91	345.1	BM30G06-../DSE06LA4	47	12000	15000
0.12	3.5	440	0.8	385.8	BM30G06-../DSE06LA4	47	12000	15000
0.12	6.4	220	3.1	211.5	BM40Z-../DSE06LA4	64	20000	25000
0.12	5.5	250	2.7	246.6	BM40Z-../DSE06LA4	64	20000	25000
0.12	4.7	295	2.0	289.8	BM40Z-../DSE06LA4	64	20000	25000
0.12	3.9	355	1.45	348.7	BM40Z-../DSE06LA4	64	20000	25000
0.12	3.2	425	1.2	430.0	BM40Z-../DSE06LA4	64	20000	25000
0.12	2.8	550	1.25	487.3	BM40G10-../DSE06LA4	68	20000	25000
0.12	2.5	610	1.1	540.0	BM40G10-../DSE06LA4	68	20000	25000
0.12	2.1	730	0.93	660.2	BM40G10-../DSE06LA4	68	20000	25000
0.12	1.8	850	0.8	756.7	BM40G10-../DSE06LA4	68	20000	25000
0.12	120	17.5	1.7	11.34	BM09-../DSE05LA4	13	4400	6500
0.12	103	20	1.6	13.23	BM09-../DSE05LA4	13	4400	6500
0.12	77	27	1.75	17.73	BM09-../DSE05LA4	13	4400	6500
0.12	64	32.5	1.7	21.20	BM09-../DSE05LA4	13	4400	6500
0.12	55	38	1.55	24.74	BM09-../DSE05LA4	13	4400	6500
0.12	52	40	1.75	25.98	BM09-../DSE05LA4	13	4400	6500
0.12	45	46.5	1.55	30.31	BM09-../DSE05LA4	13	4400	6500
0.12	41	51	1.7	32.97	BM09-../DSE05LA4	13	4400	6500
0.12	35.5	59	1.55	38.46	BM09-../DSE05LA4	13	4400	6500
0.12	32	64	1.35	42.44	BM09-../DSE05LA4	13	4400	6500
0.12	25.5	81	1.35	53.85	BM09-../DSE05LA4	13	4400	6500
0.12	41	50	3.0	33.19	BM10-../DSE06LA4	21	8000	10000
0.12	37	55	2.9	36.82	BM10-../DSE06LA4	21	8000	10000
0.12	33.5	59	2.5	40.56	BM10-../DSE06LA4	21	8000	10000
0.12	30	66	2.4	45.00	BM10-../DSE06LA4	21	8000	10000
0.12	26	75	2.0	52.44	BM10-../DSE06LA4	21	8000	10000
0.12	23.5	83	1.95	58.18	BM10-../DSE06LA4	21	8000	10000
0.12	23	94	1.6	58.79	BM10G06-../DSE06LA4	26	8000	10000
0.12	19.5	111	1.25	69.61	BM10G06-../DSE06LA4	26	8000	10000
0.12	18.5	114	1.25	74.41	BM10G06-../DSE06LA4	26	8000	10000
0.12	16.5	128	1.2	82.54	BM10G06-../DSE06LA4	26	8000	10000
0.12	15	144	1.05	90.78	BM10G06-../DSE06LA4	26	8000	10000
0.12	13.5	155	0.97	102.7	BM10G06-../DSE06LA4	26	8000	10000
0.12	11.5	182	0.82	120.5	BM10G06-../DSE06LA4	26	8000	10000
0.12	10.5	200	0.8	133.7	BM10G06-../DSE06LA4	26	8000	10000
0.12	32.5	69	3.2	42.18	BM20-../DSE06LA4	23	12000	12000
0.12	26	87	2.4	52.84	BM20-../DSE06LA4	23	12000	12000
0.12	22.5	100	1.95	60.64	BM20-../DSE06LA4	23	12000	12000
0.12	18.5	122	1.5	74.76	BM20-../DSE06LA4	23	12000	12000
0.12	16	141	1.55	85.45	BM20Z-../DSE06LA4	24	12000	12000
0.12	14	162	1.35	99.47	BM20Z-../DSE06LA4	24	12000	12000
0.12	11.5	197	1.1	117.9	BM20Z-../DSE06LA4	24	12000	12000
0.12	9.5	235	0.94	142.8	BM20Z-../DSE06LA4	24	12000	12000
0.12	22.5	93	2.9	61.33	BM30-../DSE06LA4	39	12000	15000
0.12	19	110	2.3	71.09	BM30-../DSE06LA4	39	12000	15000
0.12	16	129	2.7	85.96	BM30Z-../DSE06LA4	41	12000	15000
0.12	13.5	152	2.3	100.7	BM30Z-../DSE06LA4	41	12000	15000
0.12	11	186	1.9	128.2	BM30Z-../DSE06LA4	41	12000	15000
0.12	9.0	225	1.55	150.3	BM30Z-../DSE06LA4	41	12000	15000
0.12	7.7	260	1.35	177.2	BM30Z-../DSE06LA4	41	12000	15000
0.12	7.3	290	1.2	186.7	BM30G06-../DSE06LA4	47	12000	15000
0.12	6.5	330	1.05	208.6	BM30G06-../DSE06LA4	47	12000	15000
0.12	5.6	380	0.92	245.1	BM30G06-../DSE06LA4	47	12000	15000
0.12	9.5	210	3.2	143.0	BM40Z-../DSE06LA4	64	20000	25000
0.12	8.0	245	2.8	169.0	BM40Z-../DSE06LA4	64	20000	25000

# Geared motors for electric overhead conveyors series BM

## Selection table asynchronous motors ASM IE1

### 0.12 kW

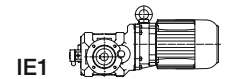

P <sub>N</sub> [kW]	n <sub>2</sub> [1/min]	50 Hz		i [:1]	Type	m [kg]	F <sub>RN</sub> [N]	F <sub>RV</sub> [N]
		M <sub>2</sub> [Nm]	f <sub>B</sub> [-]					
0.12	6.4	305	2.2	211.5	BM40Z-../DSE06LA4	64	20000	25000
0.12	5.5	350	1.95	246.6	BM40Z-../DSE06LA4	64	20000	25000
0.12	4.7	410	1.45	289.8	BM40Z-../DSE06LA4	64	20000	25000
0.12	3.9	495	1.0	348.7	BM40Z-../DSE06LA4	64	20000	25000
0.12	3.2	590	0.85	430.0	BM40Z-../DSE06LA4	64	20000	25000
0.12	2.8	760	0.89	487.3	BM40G10-../DSE06LA4	68	20000	25000
0.12	2.5	850	0.8	540.0	BM40G10-../DSE06LA4	68	20000	25000

### 0.37 kW

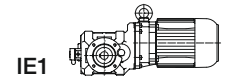

P <sub>N</sub> [kW]	n <sub>2</sub> [1/min]	50 Hz		i [:1]	Type	m [kg]	F <sub>RN</sub> [N]	F <sub>RV</sub> [N]
		M <sub>2</sub> [Nm]	f <sub>B</sub> [-]					
0.37	120	25.5	1.2	11.34	BM09-../DSE07LA4	17	4400	6500
0.37	103	30	1.05	13.23	BM09-../DSE07LA4	17	4400	6500
0.37	77	40	1.2	17.73	BM09-../DSE07LA4	17	4400	6500
0.37	64	48.5	1.15	21.20	BM09-../DSE07LA4	17	4400	6500
0.37	55	56	1.05	24.74	BM09-../DSE07LA4	17	4400	6500
0.37	52	59	1.15	25.98	BM09-../DSE07LA4	17	4400	6500
0.37	45	69	1.05	30.31	BM09-../DSE07LA4	17	4400	6500
0.37	41	75	1.15	32.97	BM09-../DSE07LA4	17	4400	6500
0.37	35.5	87	1.05	38.46	BM09-../DSE07LA4	17	4400	6500
0.37	32	96	0.89	42.44	BM09-../DSE07LA4	17	4400	6500
0.37	25.5	120	0.9	53.85	BM09-../DSE07LA4	17	4400	6500
0.37	60	51	2.9	22.62	BM10-../DSE07LA4	23	8000	10000
0.37	54	57	2.8	25.09	BM10-../DSE07LA4	23	8000	10000
0.37	51	60	2.5	26.55	BM10-../DSE07LA4	23	8000	10000
0.37	46	67	2.4	29.45	BM10-../DSE07LA4	23	8000	10000
0.37	41	74	2.0	33.19	BM10-../DSE07LA4	23	8000	10000
0.37	37	82	1.95	36.82	BM10-../DSE07LA4	23	8000	10000
0.37	33.5	88	1.7	40.56	BM10-../DSE07LA4	23	8000	10000
0.37	30	98	1.65	45.00	BM10-../DSE07LA4	23	8000	10000
0.37	26	111	1.35	52.44	BM10-../DSE07LA4	23	8000	10000
0.37	23.5	123	1.3	58.18	BM10-../DSE07LA4	23	8000	10000
0.37	23	139	1.1	58.79	BM10G06-../DSE07LA4	28	8000	10000
0.37	19.5	164	0.85	69.61	BM10G06-../DSE07LA4	28	8000	10000
0.37	18.5	169	0.86	74.41	BM10G06-../DSE07LA4	28	8000	10000
0.37	16.5	190	0.82	82.54	BM10G06-../DSE07LA4	28	8000	10000
0.37	46	72	3.1	29.39	BM20-../DSE07LA4	26	12000	12000
0.37	38.5	87	2.5	35.25	BM20-../DSE07LA4	26	12000	12000
0.37	32.5	103	2.1	42.18	BM20-../DSE07LA4	26	12000	12000
0.37	26	129	1.6	52.84	BM20-../DSE07LA4	26	12000	12000
0.37	22.5	149	1.3	60.64	BM20-../DSE07LA4	26	12000	12000
0.37	18.5	181	1.0	74.76	BM20-../DSE07LA4	26	12000	12000
0.37	16	205	1.05	85.45	BM20Z-../DSE07LA4	27	12000	12000
0.37	14	235	0.94	99.47	BM20Z-../DSE07LA4	27	12000	12000
0.37	27.5	114	2.8	49.66	BM30-../DSE07LA4	41	12000	15000
0.37	22.5	138	1.95	61.33	BM30-../DSE07LA4	41	12000	15000
0.37	19	163	1.6	71.09	BM30-../DSE07LA4	41	12000	15000
0.37	16	192	1.8	85.96	BM30Z-../DSE07LA4	44	12000	15000
0.37	13.5	225	1.55	100.7	BM30Z-../DSE07LA4	44	12000	15000
0.37	11	275	1.25	128.2	BM30Z-../DSE07LA4	44	12000	15000
0.37	9.0	330	1.05	150.3	BM30Z-../DSE07LA4	44	12000	15000
0.37	7.7	390	0.9	177.2	BM30Z-../DSE07LA4	44	12000	15000
0.37	7.3	435	0.8	186.7	BM30G06-../DSE07LA4	50	12000	15000
0.37	11.5	260	2.6	118.2	BM40Z-../DSE07LA4	66	20000	25000
0.37	9.5	310	2.2	143.0	BM40Z-../DSE07LA4	66	20000	25000
0.37	8.0	365	1.85	169.0	BM40Z-../DSE07LA4	66	20000	25000
0.37	6.4	450	1.5	211.5	BM40Z-../DSE07LA4	66	20000	25000
0.37	5.5	520	1.3	246.6	BM40Z-../DSE07LA4	66	20000	25000
0.37	4.7	600	1.0	289.8	BM40Z-../DSE07LA4	66	20000	25000



# Geared motors for electric overhead conveyors series BM

## Selection table asynchronous motors ASM IE1

### 0.55 kW

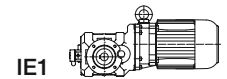

P <sub>N</sub> [kW]	50 Hz			i [:1]	Type	m [kg]	F <sub>RN</sub> [N]	F <sub>RV</sub> [N]
	n <sub>2</sub> [1/min]	M <sub>2</sub> [Nm]	f <sub>B</sub> [-]					
0.55	124	37	0.81	11.34	BM09-../DSE08MA4	18	4400	6500
0.55	79	58	0.81	17.73	BM09-../DSE08MA4	18	4400	6500
0.55	67	68	0.82	21.20	BM09-../DSE08MA4	18	4400	6500
0.55	54	85	0.81	25.98	BM09-../DSE08MA4	18	4400	6500
0.55	42.5	108	0.81	32.97	BM09-../DSE08MA4	18	4400	6500
0.55	86	54	2.7	16.39	BM10-../DSE08MA4	24	8000	10000
0.55	78	59	2.6	18.18	BM10-../DSE08MA4	24	8000	10000
0.55	62	74	2.0	22.62	BM10-../DSE08MA4	24	8000	10000
0.55	56	82	1.95	25.09	BM10-../DSE08MA4	24	8000	10000
0.55	53	87	1.7	26.55	BM10-../DSE08MA4	24	8000	10000
0.55	48	96	1.65	29.45	BM10-../DSE08MA4	24	8000	10000
0.55	42.5	106	1.4	33.19	BM10-../DSE08MA4	24	8000	10000
0.55	38.5	117	1.35	36.82	BM10-../DSE08MA4	24	8000	10000
0.55	35	126	1.2	40.56	BM10-../DSE08MA4	24	8000	10000
0.55	31.5	140	1.15	45.00	BM10-../DSE08MA4	24	8000	10000
0.55	27	159	0.94	52.44	BM10-../DSE08MA4	24	8000	10000
0.55	24.5	175	0.91	58.18	BM10-../DSE08MA4	24	8000	10000
0.55	71	70	3.1	19.72	BM20-../DSE08MA4	26	12000	12000
0.55	56	89	2.5	25.25	BM20-../DSE08MA4	26	12000	12000
0.55	48	103	2.1	29.39	BM20-../DSE08MA4	26	12000	12000
0.55	40	124	1.75	35.25	BM20-../DSE08MA4	26	12000	12000
0.55	33.5	148	1.5	42.18	BM20-../DSE08MA4	26	12000	12000
0.55	26.5	188	1.1	52.84	BM20-../DSE08MA4	26	12000	12000
0.55	23.5	210	0.92	60.64	BM20-../DSE08MA4	26	12000	12000
0.55	21	235	0.94	66.74	BM20Z-../DSE08MA4	28	12000	12000
0.55	40.5	118	3.0	34.88	BM30-../DSE08MA4	42	12000	15000
0.55	34.5	137	2.6	41.13	BM30-../DSE08MA4	42	12000	15000
0.55	28.5	164	1.95	49.66	BM30-../DSE08MA4	42	12000	15000
0.55	23	200	1.35	61.33	BM30-../DSE08MA4	42	12000	15000
0.55	20	230	1.1	71.09	BM30-../DSE08MA4	42	12000	15000
0.55	16.5	275	1.25	85.96	BM30Z-../DSE08MA4	45	12000	15000
0.55	14	320	1.1	100.7	BM30Z-../DSE08MA4	45	12000	15000
0.55	11	410	0.85	128.2	BM30Z-../DSE08MA4	45	12000	15000
0.55	20	225	3.0	70.11	BM40-../DSE08MA4	63	20000	25000
0.55	17	265	2.3	84.36	BM40-../DSE08MA4	63	20000	25000
0.55	13.5	330	1.8	104.0	BM40-../DSE08MA4	63	20000	25000
0.55	12	370	1.85	118.2	BM40Z-../DSE08MA4	67	20000	25000
0.55	9.8	450	1.5	143.0	BM40Z-../DSE08MA4	67	20000	25000
0.55	8.3	520	1.3	169.0	BM40Z-../DSE08MA4	67	20000	25000
0.55	6.7	640	1.05	211.5	BM40Z-../DSE08MA4	67	20000	25000
0.55	5.7	740	0.92	246.6	BM40Z-../DSE08MA4	67	20000	25000

### 0.75 kW

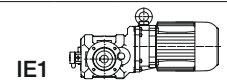

P <sub>N</sub> [kW]	50 Hz			i [:1]	Type	m [kg]	F <sub>RN</sub> [N]	F <sub>RV</sub> [N]
	n <sub>2</sub> [1/min]	M <sub>2</sub> [Nm]	f <sub>B</sub> [-]					
0.75	120	54	2.6	11.68	BM10-../DSE08LA4	26	8000	10000
0.75	109	59	2.5	12.95	BM10-../DSE08LA4	26	8000	10000
0.75	86	74	1.95	16.39	BM10-../DSE08LA4	26	8000	10000
0.75	78	81	1.9	18.18	BM10-../DSE08LA4	26	8000	10000
0.75	62	101	1.5	22.62	BM10-../DSE08LA4	26	8000	10000
0.75	56	112	1.45	25.09	BM10-../DSE08LA4	26	8000	10000
0.75	53	118	1.25	26.55	BM10-../DSE08LA4	26	8000	10000
0.75	48	131	1.2	29.45	BM10-../DSE08LA4	26	8000	10000
0.75	42.5	144	1.05	33.19	BM10-../DSE08LA4	26	8000	10000
0.75	38.5	159	1.0	36.82	BM10-../DSE08LA4	26	8000	10000
0.75	35	171	0.88	40.56	BM10-../DSE08LA4	26	8000	10000
0.75	31.5	191	0.84	45.00	BM10-../DSE08LA4	26	8000	10000
0.75	84	81	2.7	16.72	BM20-../DSE08LA4	28	12000	12000
0.75	71	95	2.3	19.72	BM20-../DSE08LA4	28	12000	12000
0.75	56	121	1.8	25.25	BM20-../DSE08LA4	28	12000	12000
0.75	48	141	1.55	29.39	BM20-../DSE08LA4	28	12000	12000

# Geared motors for electric overhead conveyors series BM

## Selection table asynchronous motors ASM IE1

### 0.75 kW

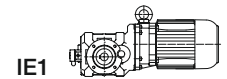

P <sub>N</sub> [kW]	50 Hz			i [:1]	Type	m [kg]	F <sub>RN</sub> [N]	F <sub>RV</sub> [N]
	n <sub>2</sub> [1/min]	M <sub>2</sub> [Nm]	f <sub>B</sub> [-]					
0.75	40	170	1.3	35.25	BM20-../DSE08LA4	28	12000	12000
0.75	33.5	200	1.1	42.18	BM20-../DSE08LA4	28	12000	12000
0.75	26.5	255	0.82	52.84	BM20-../DSE08LA4	28	12000	12000
0.75	25	270	0.81	56.58	BM20Z-../DSE08LA4	30	12000	12000
0.75	60	108	3.2	23.38	BM30-../DSE08LA4	44	12000	15000
0.75	47.5	137	2.6	29.76	BM30-../DSE08LA4	44	12000	15000
0.75	40.5	160	2.2	34.88	BM30-../DSE08LA4	44	12000	15000
0.75	34.5	186	1.9	41.13	BM30-../DSE08LA4	44	12000	15000
0.75	28.5	220	1.45	49.66	BM30-../DSE08LA4	44	12000	15000
0.75	23	270	1.0	61.33	BM30-../DSE08LA4	44	12000	15000
0.75	20	315	0.82	71.09	BM30-../DSE08LA4	44	12000	15000
0.75	16.5	375	0.93	85.96	BM30Z-../DSE08LA4	46	12000	15000
0.75	14	435	0.8	100.7	BM30Z-../DSE08LA4	46	12000	15000
0.75	27.5	225	3.0	51.18	BM40-../DSE08LA4	64	20000	25000
0.75	23.5	265	2.6	59.66	BM40-../DSE08LA4	64	20000	25000
0.75	20	310	2.2	70.11	BM40-../DSE08LA4	64	20000	25000
0.75	17	365	1.65	84.36	BM40-../DSE08LA4	64	20000	25000
0.75	13.5	450	1.35	104.0	BM40-../DSE08LA4	64	20000	25000
0.75	12	500	1.35	118.2	BM40Z-../DSE08LA4	69	20000	25000
0.75	9.8	610	1.1	143.0	BM40Z-../DSE08LA4	69	20000	25000
0.75	8.3	710	0.96	169.0	BM40Z-../DSE08LA4	69	20000	25000

6

### 1.1 kW

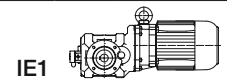

P <sub>N</sub> [kW]	50 Hz			i [:1]	Type	m [kg]	F <sub>RN</sub> [N]	F <sub>RV</sub> [N]
	n <sub>2</sub> [1/min]	M <sub>2</sub> [Nm]	f <sub>B</sub> [-]					
1.1	120	79	1.75	11.68	BM10-../DSE08XA4	27	8000	10000
1.1	109	87	1.7	12.95	BM10-../DSE08XA4	27	8000	10000
1.1	86	108	1.35	16.39	BM10-../DSE08XA4	27	8000	10000
1.1	78	119	1.3	18.18	BM10-../DSE08XA4	27	8000	10000
1.1	62	149	1.0	22.62	BM10-../DSE08XA4	27	8000	10000
1.1	56	165	0.97	25.09	BM10-../DSE08XA4	27	8000	10000
1.1	53	174	0.86	26.55	BM10-../DSE08XA4	27	8000	10000
1.1	48	192	0.83	29.45	BM10-../DSE08XA4	27	8000	10000
1.1	138	72	3.1	10.15	BM20-../DSE08XA4	29	12000	12000
1.1	105	95	2.3	13.34	BM20-../DSE08XA4	29	12000	12000
1.1	84	118	1.85	16.72	BM20-../DSE08XA4	29	12000	12000
1.1	71	140	1.55	19.72	BM20-../DSE08XA4	29	12000	12000
1.1	56	178	1.25	25.25	BM20-../DSE08XA4	29	12000	12000
1.1	48	205	1.05	29.39	BM20-../DSE08XA4	29	12000	12000
1.1	40	245	0.9	35.25	BM20-../DSE08XA4	29	12000	12000
1.1	87	111	3.2	16.10	BM30-../DSE08XA4	45	12000	15000
1.1	71	136	2.6	19.96	BM30-../DSE08XA4	45	12000	15000
1.1	60	159	2.2	23.38	BM30-../DSE08XA4	45	12000	15000
1.1	47.5	200	1.75	29.76	BM30-../DSE08XA4	45	12000	15000
1.1	40.5	235	1.5	34.88	BM30-../DSE08XA4	45	12000	15000
1.1	34.5	270	1.3	41.13	BM30-../DSE08XA4	45	12000	15000
1.1	28.5	325	0.97	49.66	BM30-../DSE08XA4	45	12000	15000
1.1	26.5	340	0.82	53.67	BM30Z-../DSE08XA4	48	12000	15000
1.1	40.5	230	3.0	34.61	BM40-../DSE08XA4	65	20000	25000
1.1	34.5	270	2.5	40.88	BM40-../DSE08XA4	65	20000	25000
1.1	27.5	335	2.0	51.18	BM40-../DSE08XA4	65	20000	25000
1.1	23.5	390	1.75	59.66	BM40-../DSE08XA4	65	20000	25000
1.1	20	455	1.5	70.11	BM40-../DSE08XA4	65	20000	25000
1.1	17	530	1.15	84.36	BM40-../DSE08XA4	65	20000	25000
1.1	13.5	660	0.91	104.0	BM40-../DSE08XA4	65	20000	25000
1.1	12	740	0.92	118.2	BM40Z-../DSE08XA4	70	20000	25000

# Geared motors for electric overhead conveyors series BM

## Selection table asynchronous motors ASM IE1

### 1.5 kW

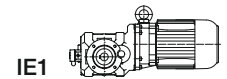

P <sub>N</sub> [kW]	50 Hz			i [:1]	Type	m [kg]	F <sub>RN</sub> [N]	F <sub>RV</sub> [N]
	n <sub>2</sub> [1/min]	M <sub>2</sub> [Nm]	f <sub>B</sub> [—]					
1.5	122	106	1.3	11.68	BM10-../DSE09LA4	34	8000	10000
1.5	110	118	1.25	12.95	BM10-../DSE09LA4	34	8000	10000
1.5	87	146	0.99	16.39	BM10-../DSE09LA4	34	8000	10000
1.5	79	161	0.96	18.18	BM10-../DSE09LA4	34	8000	10000
1.5	186	73	2.7	7.66	BM20-../DSE09LA4	36	9100	10900
1.5	140	97	2.3	10.15	BM20-../DSE09LA4	36	12000	12000
1.5	107	127	1.75	13.34	BM20-../DSE09LA4	36	12000	12000
1.5	85	160	1.4	16.72	BM20-../DSE09LA4	36	12000	12000
1.5	73	186	1.2	19.72	BM20-../DSE09LA4	36	12000	12000
1.5	57	235	0.94	25.25	BM20-../DSE09LA4	36	12000	12000
1.5	114	115	3.0	12.46	BM30-../DSE09LA4	52	12000	15000
1.5	89	148	2.4	16.10	BM30-../DSE09LA4	52	12000	15000
1.5	72	183	1.9	19.96	BM30-../DSE09LA4	52	12000	15000
1.5	61	210	1.65	23.38	BM30-../DSE09LA4	52	12000	15000
1.5	48	270	1.3	29.76	BM30-../DSE09LA4	52	12000	15000
1.5	41	315	1.1	34.88	BM30-../DSE09LA4	52	12000	15000
1.5	35	365	0.96	41.13	BM30-../DSE09LA4	52	12000	15000
1.5	50	255	2.7	28.59	BM40-../DSE09LA4	72	20000	25000
1.5	41.5	310	2.2	34.61	BM40-../DSE09LA4	72	20000	25000
1.5	35	365	1.85	40.88	BM40-../DSE09LA4	72	20000	25000
1.5	28	450	1.5	51.18	BM40-../DSE09LA4	72	20000	25000
1.5	24	520	1.3	59.66	BM40-../DSE09LA4	72	20000	25000
1.5	20.5	600	1.15	70.11	BM40-../DSE09LA4	72	20000	25000
1.5	17	730	0.82	84.36	BM40-../DSE09LA4	72	20000	25000

### 2.2 kW

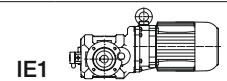

P <sub>N</sub> [kW]	50 Hz			i [:1]	Type	m [kg]	F <sub>RN</sub> [N]	F <sub>RV</sub> [N]
	n <sub>2</sub> [1/min]	M <sub>2</sub> [Nm]	f <sub>B</sub> [—]					
2.2	122	156	0.9	11.68	BM10-../DSE09XA4	38	8000	10000
2.2	110	173	0.87	12.95	BM10-../DSE09XA4	38	8000	10000
2.2	186	107	1.85	7.66	BM20-../DSE09XA4	40	9100	10900
2.2	140	142	1.55	10.15	BM20-../DSE09XA4	40	12000	12000
2.2	107	186	1.2	13.34	BM20-../DSE09XA4	40	12000	12000
2.2	85	230	0.96	16.72	BM20-../DSE09XA4	40	12000	12000
2.2	73	270	0.81	19.72	BM20-../DSE09XA4	40	12000	12000
2.2	180	107	3.0	7.91	BM30-../DSE09XA4	56	11000	13800
2.2	142	136	2.6	10.06	BM30-../DSE09XA4	56	12000	15000
2.2	114	169	2.1	12.46	BM30-../DSE09XA4	56	12000	15000
2.2	89	215	1.65	16.10	BM30-../DSE09XA4	56	12000	15000
2.2	72	265	1.3	19.96	BM30-../DSE09XA4	56	12000	15000
2.2	61	310	1.15	23.38	BM30-../DSE09XA4	56	12000	15000
2.2	48	395	0.89	29.76	BM30-../DSE09XA4	56	12000	15000
2.2	79	235	2.9	18.05	BM40-../DSE09XA4	76	20000	25000
2.2	64	295	2.3	22.44	BM40-../DSE09XA4	76	20000	25000
2.2	50	375	1.8	28.59	BM40-../DSE09XA4	76	20000	25000
2.2	41.5	455	1.5	34.61	BM40-../DSE09XA4	76	20000	25000
2.2	35	540	1.25	40.88	BM40-../DSE09XA4	76	20000	25000
2.2	28	660	1.05	51.18	BM40-../DSE09XA4	76	20000	25000
2.2	24	770	0.88	59.66	BM40-../DSE09XA4	76	20000	25000

### 3 kW

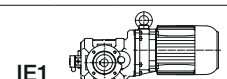

P <sub>N</sub> [kW]	50 Hz			i [:1]	Type	m [kg]	F <sub>RN</sub> [N]	F <sub>RV</sub> [N]
	n <sub>2</sub> [1/min]	M <sub>2</sub> [Nm]	f <sub>B</sub> [—]					
3	180	146	2.2	7.91	BM30-../DSE11SA4	65	11000	13800
3	142	185	1.9	10.06	BM30-../DSE11SA4	65	12000	15000



# Geared motors for electric overhead conveyors series BM

## Selection table asynchronous motors ASM IE1

### 3 kW

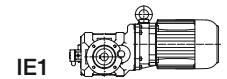

P <sub>N</sub> [kW]	n <sub>2</sub> [1/min]	50 Hz		i [:1]	Type	m [kg]	F <sub>RN</sub> [N]	F <sub>RV</sub> [N]
		M <sub>2</sub> [Nm]	f <sub>B</sub> [—]					
3	114	230	1.5	12.46	BM30-../DSE11SA4	65	12000	15000
3	89	295	1.2	16.10	BM30-../DSE11SA4	65	12000	15000
3	72	365	0.96	19.96	BM30-../DSE11SA4	65	12000	15000
3	61	425	0.82	23.38	BM30-../DSE11SA4	65	12000	15000
3	128	200	3.1	11.17	BM40-../DSE11SA4	90	18300	22900
3	98	260	2.6	14.50	BM40-../DSE11SA4	90	20000	25000
3	79	325	2.1	18.05	BM40-../DSE11SA4	90	20000	25000
3	64	400	1.7	22.44	BM40-../DSE11SA4	90	20000	25000
3	50	510	1.35	28.59	BM40-../DSE11SA4	90	20000	25000
3	41.5	620	1.1	34.61	BM40-../DSE11SA4	90	20000	25000
3	35	730	0.93	40.88	BM40-../DSE11SA4	90	20000	25000

### 4 kW

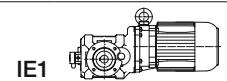

P <sub>N</sub> [kW]	n <sub>2</sub> [1/min]	50 Hz		i [:1]	Type	m [kg]	F <sub>RN</sub> [N]	F <sub>RV</sub> [N]
		M <sub>2</sub> [Nm]	f <sub>B</sub> [—]					
4	180	195	1.65	7.91	BM30-../DSE11MA4	65	11000	13800
4	142	245	1.45	10.06	BM30-../DSE11MA4	65	12000	15000
4	114	305	1.15	12.46	BM30-../DSE11MA4	65	12000	15000
4	89	390	0.9	16.10	BM30-../DSE11MA4	65	12000	15000
4	128	265	2.4	11.17	BM40-../DSE11MA4	90	18300	22900
4	98	350	1.95	14.50	BM40-../DSE11MA4	90	20000	25000
4	79	435	1.55	18.05	BM40-../DSE11MA4	90	20000	25000
4	64	530	1.3	22.44	BM40-../DSE11MA4	90	20000	25000
4	50	680	1.0	28.59	BM40-../DSE11MA4	90	20000	25000
4	41.5	820	0.83	34.61	BM40-../DSE11MA4	90	20000	25000

### 5.5 kW

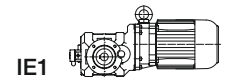

P <sub>N</sub> [kW]	n <sub>2</sub> [1/min]	50 Hz		i [:1]	Type	m [kg]	F <sub>RN</sub> [N]	F <sub>RV</sub> [N]
		M <sub>2</sub> [Nm]	f <sub>B</sub> [—]					
5.5	180	265	1.2	7.91	BM30-../DSE11LA4	76	11000	13800
5.5	142	340	1.05	10.06	BM30-../DSE11LA4	76	12000	15000
5.5	114	420	0.83	12.46	BM30-../DSE11LA4	76	12000	15000
5.5	128	365	1.7	11.17	BM40-../DSE11LA4	102	18300	22900
5.5	98	480	1.4	14.50	BM40-../DSE11LA4	102	20000	25000
5.5	79	590	1.15	18.05	BM40-../DSE11LA4	102	20000	25000
5.5	64	730	0.93	22.44	BM40-../DSE11LA4	102	20000	25000

# Geared motors for electric overhead conveyors series BM

## Selection table asynchronous motors ASM IE1

---

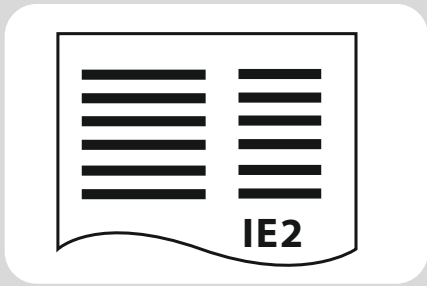

### Selection tables ASM-IE2

Selection table asynchronous motors ASM IE2 .....65

# Energy Efficient Geared Motors

## Electric overhead conveyors series BM

---

# Geared motors for electric overhead conveyors series BM

## Selection table asynchronous motors ASM IE2

0.12 kW

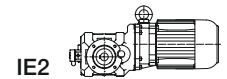

P <sub>N</sub>	50 Hz			i	Typ	m	F <sub>RN</sub>	F <sub>RV</sub>
	n <sub>2</sub>	M <sub>2</sub>	f <sub>B</sub>					
[kW]	[1/min]	[Nm]	[—]	[:1]		[kg]	[N]	[N]
0.12	123	8.1	3.7	11.34	BM09-../DHE05LA4	13	4400	6500
0.12	106	9.5	3.4	13.23	BM09-../DHE05LA4	13	4400	6500
0.12	79	12.7	3.7	17.73	BM09-../DHE05LA4	13	4400	6500
0.12	66	15.2	3.7	21.20	BM09-../DHE05LA4	13	4400	6500
0.12	57	17.6	3.4	24.74	BM09-../DHE05LA4	13	4400	6500
0.12	54	18.6	3.7	25.98	BM09-../DHE05LA4	13	4400	6500
0.12	46	21.5	3.3	30.31	BM09-../DHE05LA4	13	4400	6500
0.12	42.5	23.5	3.7	32.97	BM09-../DHE05LA4	13	4400	6500
0.12	36.5	27.5	3.3	38.46	BM09-../DHE05LA4	13	4400	6500
0.12	33	30	2.8	42.44	BM09-../DHE05LA4	13	4400	6500
0.12	26	38	2.8	53.85	BM09-../DHE05LA4	13	4400	6500
0.12	20	52	2.7	69.61	BM10G06-../DHE06LA4	26	8000	10000
0.12	19	53	2.7	74.41	BM10G06-../DHE06LA4	26	8000	10000
0.12	17	59	2.6	82.54	BM10G06-../DHE06LA4	26	8000	10000
0.12	15.5	67	2.2	90.78	BM10G06-../DHE06LA4	26	8000	10000
0.12	13.5	74	2.0	102.7	BM10G06-../DHE06LA4	26	8000	10000
0.12	11.5	87	1.7	120.5	BM10G06-../DHE06LA4	26	8000	10000
0.12	10.5	96	1.65	133.7	BM10G06-../DHE06LA4	26	8000	10000
0.12	9.2	107	1.4	150.7	BM10G06-../DHE06LA4	26	8000	10000
0.12	8.3	118	1.35	167.2	BM10G06-../DHE06LA4	26	8000	10000
0.12	7.3	138	1.1	189.8	BM10G06-../DHE06LA4	26	8000	10000
0.12	6.4	153	1.05	219.4	BM10G06-../DHE06LA4	26	8000	10000
0.12	5.4	182	0.88	258.1	BM10G06-../DHE06LA4	26	8000	10000
0.12	4.5	160*	1.0	308.9	BM10G06-../DHE06LA4	26	8000	10000
0.12	4.1	160*	1.0	345.4	BM10G06-../DHE06LA4	26	8000	10000
0.12	3.7	160*	1.0	377.0	BM10G06-../DHE06LA4	26	8000	10000
0.12	3.4	160*	1.0	415.3	BM10G06-../DHE06LA4	26	8000	10000
0.12	3.1	160*	1.0	452.9	BM10G06-../DHE06LA4	26	8000	10000
0.12	2.6	160*	1.0	544.2	BM10G06-../DHE06LA4	26	8000	10000
0.12	2.4	160*	1.0	593.9	BM10G06-../DHE06LA4	26	8000	10000
0.12	2.0	160*	1.0	698.8	BM10G06-../DHE06LA4	26	8000	10000
0.12	1.7	160*	1.0	836.2	BM10G06-../DHE06LA4	26	8000	10000
0.12	1.5	160*	1.0	938.2	BM10G06-../DHE06LA4	26	8000	10000
0.12	1.2	160*	1.0	1186	BM10G06-../DHE06LA4	26	8000	10000
0.12	0.95	160*	1.0	1482	BM10G06-../DHE06LA4	26	8000	10000
0.12	0.85	160*	1.0	1701	BM10G06-../DHE06LA4	26	8000	10000
0.12	0.75	160*	1.0	1935	BM10G06-../DHE06LA4	26	8000	10000
0.12	0.7	160*	1.0	2111	BM10G06-../DHE06LA4	26	8000	10000
0.12	0.65	160*	1.0	2254	BM10G06-../DHE06LA4	26	8000	10000
0.12	0.6	160*	1.0	2459	BM10G06-../DHE06LA4	26	8000	10000
0.12	19	57	3.2	74.76	BM20-../DHE06LA4	23	12000	12000
0.12	14	77	2.9	99.47	BM20Z-../DHE06LA4	24	12000	12000
0.12	12	90	2.4	117.9	BM20Z-../DHE06LA4	24	12000	12000
0.12	9.7	112	1.95	142.8	BM20Z-../DHE06LA4	24	12000	12000
0.12	7.8	139	1.5	178.9	BM20Z-../DHE06LA4	24	12000	12000
0.12	6.8	160	1.2	205.3	BM20Z-../DHE06LA4	24	12000	12000
0.12	5.5	197	0.92	253.0	BM20Z-../DHE06LA4	24	12000	12000
0.12	7.9	123	2.8	177.2	BM30Z-../DHE06LA4	41	12000	15000
0.12	7.5	137	2.6	186.7	BM30G06-../DHE06LA4	47	12000	15000
0.12	6.7	155	2.3	208.6	BM30G06-../DHE06LA4	47	12000	15000
0.12	5.7	180	1.95	245.1	BM30G06-../DHE06LA4	47	12000	15000
0.12	4.9	210	1.65	288.3	BM30G06-../DHE06LA4	47	12000	15000
0.12	4.1	250	1.4	345.1	BM30G06-../DHE06LA4	47	12000	15000
0.12	3.6	285	1.25	385.8	BM30G06-../DHE06LA4	47	12000	15000
0.12	3.0	340	1.05	463.9	BM30G06-../DHE06LA4	47	12000	15000
0.12	2.6	395	0.89	533.9	BM30G06-../DHE06LA4	47	12000	15000
0.12	2.1	350*	1.0	663.4	BM30G06-../DHE06LA4	47	12000	15000
0.12	1.8	350*	1.0	780.6	BM30G06-../DHE06LA4	47	12000	15000
0.12	1.5	350*	1.0	934.1	BM30G06-../DHE06LA4	47	12000	15000
0.12	1.3	350*	1.0	1143	BM30G06-../DHE06LA4	47	12000	15000
0.12	1.1	350*	1.0	1325	BM30G06-../DHE06LA4	47	12000	15000
0.12	0.95	350*	1.0	1518	BM30G06-../DHE06LA4	47	12000	15000
0.12	0.85	350*	1.0	1656	BM30G06-../DHE06LA4	47	12000	15000
0.12	0.75	350*	1.0	1900	BM30G06-../DHE06LA4	47	12000	15000
0.12	0.65	350*	1.0	2162	BM30G06-../DHE06LA4	47	12000	15000
0.12	0.6	350*	1.0	2358	BM30G06-../DHE06LA4	47	12000	15000
0.12	0.55	350*	1.0	2747	BM30G06-../DHE06LA4	47	12000	15000

7

# Geared motors for electric overhead conveyors series BM

## Selection table asynchronous motors ASM IE2

### 0.12 kW

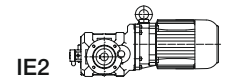

P <sub>N</sub> [kW]	50 Hz			i [:1]	Typ	m [kg]	F <sub>RN</sub> [N]	F <sub>RV</sub> [N]
	n <sub>2</sub> [1/min]	M <sub>2</sub> [Nm]	f <sub>B</sub> [-]					
0.12	4.8	193	3.1	289.8	BM40Z-../DHE06LA4	64	20000	25000
0.12	4.0	230	2.2	348.7	BM40Z-../DHE06LA4	64	20000	25000
0.12	3.3	275	1.8	430.0	BM40Z-../DHE06LA4	64	20000	25000
0.12	2.9	355	1.9	487.3	BM40G10-../DHE06LA4	68	20000	25000
0.12	2.6	395	1.7	540.0	BM40G10-../DHE06LA4	68	20000	25000
0.12	2.1	490	1.4	660.2	BM40G10-../DHE06LA4	68	20000	25000
0.12	1.9	540	1.25	756.7	BM40G10-../DHE06LA4	68	20000	25000
0.12	1.7	600	1.15	838.4	BM40G10-../DHE06LA4	68	20000	25000
0.12	1.4	730	0.93	998.3	BM40G10-../DHE06LA4	68	20000	25000
0.12	1.2	850	0.8	1189	BM40G10-../DHE06LA4	68	20000	25000
0.12	1.0	680*	1.0	1428	BM40G10-../DHE06LA4	68	20000	25000
0.12	0.8	680*	1.0	1798	BM40G10-../DHE06LA4	68	20000	25000
0.12	0.7	680*	1.0	2108	BM40G10-../DHE06LA4	68	20000	25000
0.12	0.6	680*	1.0	2350	BM40G10-../DHE06LA4	68	20000	25000
0.12	0.55	680*	1.0	2604	BM40G10-../DHE06LA4	68	20000	25000
0.12	0.46	680*	1.0	3077	BM40G10-../DHE06LA4	68	20000	25000
0.12	0.41	680*	1.0	3429	BM40G10-../DHE06LA4	68	20000	25000
0.12	0.37	680*	1.0	3800	BM40G10-../DHE06LA4	68	20000	25000
0.12	0.32	680*	1.0	4363	BM40G10-../DHE06LA4	68	20000	25000

7

### 0.18 kW

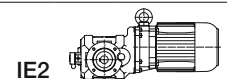

P <sub>N</sub> [kW]	50 Hz			i [:1]	Typ	m [kg]	F <sub>RN</sub> [N]	F <sub>RV</sub> [N]
	n <sub>2</sub> [1/min]	M <sub>2</sub> [Nm]	f <sub>B</sub> [-]					
0.18	122	12.3	2.4	11.34	BM09-../DHE05LA4	13	4400	6500
0.18	104	14.5	2.2	13.23	BM09-../DHE05LA4	13	4400	6500
0.18	78	19.3	2.4	17.73	BM09-../DHE05LA4	13	4400	6500
0.18	65	23	2.4	21.20	BM09-../DHE05LA4	13	4400	6500
0.18	56	27	2.2	24.74	BM09-../DHE05LA4	13	4400	6500
0.18	53	28.5	2.4	25.98	BM09-../DHE05LA4	13	4400	6500
0.18	45.5	33	2.2	30.31	BM09-../DHE05LA4	13	4400	6500
0.18	42	36	2.4	32.97	BM09-../DHE05LA4	13	4400	6500
0.18	36	42	2.2	38.46	BM09-../DHE05LA4	13	4400	6500
0.18	32.5	46	1.85	42.44	BM09-../DHE05LA4	13	4400	6500
0.18	26	57	1.9	53.85	BM09-../DHE05LA4	13	4400	6500
0.18	26.5	53	2.8	52.44	BM10-../DHE06LA4	21	8000	10000
0.18	24	58	2.8	58.18	BM10-../DHE06LA4	21	8000	10000
0.18	23.5	66	2.3	58.79	BM10G06-../DHE06LA4	26	8000	10000
0.18	20	78	1.8	69.61	BM10G06-../DHE06LA4	26	8000	10000
0.18	18.5	82	1.75	74.41	BM10G06-../DHE06LA4	26	8000	10000
0.18	17	89	1.75	82.54	BM10G06-../DHE06LA4	26	8000	10000
0.18	15.5	100	1.5	90.78	BM10G06-../DHE06LA4	26	8000	10000
0.18	13.5	112	1.35	102.7	BM10G06-../DHE06LA4	26	8000	10000
0.18	11.5	131	1.15	120.5	BM10G06-../DHE06LA4	26	8000	10000
0.18	10.5	144	1.1	133.7	BM10G06-../DHE06LA4	26	8000	10000
0.18	9.1	162	0.93	150.7	BM10G06-../DHE06LA4	26	8000	10000
0.18	8.2	180	0.89	167.2	BM10G06-../DHE06LA4	26	8000	10000
0.18	23	71	2.7	60.64	BM20-../DHE06LA4	23	12000	12000
0.18	18.5	88	2.1	74.76	BM20-../DHE06LA4	23	12000	12000
0.18	16.5	98	2.2	85.45	BM20Z-../DHE06LA4	24	12000	12000
0.18	14	116	1.9	99.47	BM20Z-../DHE06LA4	24	12000	12000
0.18	12	136	1.6	117.9	BM20Z-../DHE06LA4	24	12000	12000
0.18	9.6	170	1.3	142.8	BM20Z-../DHE06LA4	24	12000	12000
0.18	7.7	210	1.0	178.9	BM20Z-../DHE06LA4	24	12000	12000
0.18	6.7	240	0.8	205.3	BM20Z-../DHE06LA4	24	12000	12000
0.18	14	105	3.3	100.7	BM30Z-../DHE06LA4	41	12000	15000
0.18	11	134	2.6	128.2	BM30Z-../DHE06LA4	41	12000	15000
0.18	9.2	158	2.2	150.3	BM30Z-../DHE06LA4	41	12000	15000
0.18	7.8	187	1.85	177.2	BM30Z-../DHE06LA4	41	12000	15000
0.18	7.4	205	1.7	186.7	BM30G06-../DHE06LA4	47	12000	15000
0.18	6.6	235	1.5	208.6	BM30G06-../DHE06LA4	47	12000	15000
0.18	5.6	275	1.25	245.1	BM30G06-../DHE06LA4	47	12000	15000
0.18	4.8	320	1.1	288.3	BM30G06-../DHE06LA4	47	12000	15000
0.18	4.0	385	0.91	345.1	BM30G06-../DHE06LA4	47	12000	15000

# Geared motors for electric overhead conveyors series BM

## Selection table asynchronous motors ASM IE2

### 0.18 kW

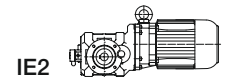

P <sub>N</sub> [kW]	50 Hz			i [:1]	Typ	m [kg]	F <sub>RN</sub> [N]	F <sub>RV</sub> [N]
	n <sub>2</sub> [1/min]	M <sub>2</sub> [Nm]	f <sub>B</sub> [-]					
0.18	3.6	425	0.82	385.8	BM30G06-../DHE06LA4	47	12000	15000
0.18	6.5	215	3.2	211.5	BM40Z-../DHE06LA4	64	20000	25000
0.18	5.6	245	2.8	246.6	BM40Z-../DHE06LA4	64	20000	25000
0.18	4.8	290	2.1	289.8	BM40Z-../DHE06LA4	64	20000	25000
0.18	4.0	345	1.45	348.7	BM40Z-../DHE06LA4	64	20000	25000
0.18	3.2	425	1.2	430.0	BM40Z-../DHE06LA4	64	20000	25000
0.18	2.9	530	1.3	487.3	BM40G10-../DHE06LA4	68	20000	25000
0.18	2.6	590	1.15	540.0	BM40G10-../DHE06LA4	68	20000	25000
0.18	2.1	730	0.93	660.2	BM40G10-../DHE06LA4	68	20000	25000
0.18	1.9	810	0.84	756.7	BM40G10-../DHE06LA4	68	20000	25000

### 0.25 kW

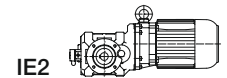

P <sub>N</sub> [kW]	50 Hz			i [:1]	Typ	m [kg]	F <sub>RN</sub> [N]	F <sub>RV</sub> [N]
	n <sub>2</sub> [1/min]	M <sub>2</sub> [Nm]	f <sub>B</sub> [-]					
0.25	122	17.2	1.75	11.34	BM09-../DHE07LA4	17	4400	6500
0.25	104	20	1.6	13.23	BM09-../DHE07LA4	17	4400	6500
0.25	78	26.5	1.75	17.73	BM09-../DHE07LA4	17	4400	6500
0.25	65	32	1.75	21.20	BM09-../DHE07LA4	17	4400	6500
0.25	56	37.5	1.55	24.74	BM09-../DHE07LA4	17	4400	6500
0.25	53	39.5	1.75	25.98	BM09-../DHE07LA4	17	4400	6500
0.25	45.5	46	1.55	30.31	BM09-../DHE07LA4	17	4400	6500
0.25	42	50	1.75	32.97	BM09-../DHE07LA4	17	4400	6500
0.25	36	58	1.6	38.46	BM09-../DHE07LA4	17	4400	6500
0.25	32.5	63	1.35	42.44	BM09-../DHE07LA4	17	4400	6500
0.25	26	79	1.35	53.85	BM09-../DHE07LA4	17	4400	6500
0.25	41.5	49	3.1	33.19	BM10-../DHE07LA4	23	8000	10000
0.25	37.5	54	3.0	36.82	BM10-../DHE07LA4	23	8000	10000
0.25	34	58	2.6	40.56	BM10-../DHE07LA4	23	8000	10000
0.25	31	64	2.5	45.00	BM10-../DHE07LA4	23	8000	10000
0.25	26.5	73	2.1	52.44	BM10-../DHE07LA4	23	8000	10000
0.25	24	81	2.0	58.18	BM10-../DHE07LA4	23	8000	10000
0.25	23.5	92	1.65	58.79	BM10G06-../DHE07LA4	28	8000	10000
0.25	20	108	1.3	69.61	BM10G06-../DHE07LA4	28	8000	10000
0.25	18.5	114	1.25	74.41	BM10G06-../DHE07LA4	28	8000	10000
0.25	17	124	1.25	82.54	BM10G06-../DHE07LA4	28	8000	10000
0.25	15.5	140	1.05	90.78	BM10G06-../DHE07LA4	28	8000	10000
0.25	13.5	155	0.97	102.7	BM10G06-../DHE07LA4	28	8000	10000
0.25	11.5	182	0.82	120.5	BM10G06-../DHE07LA4	28	8000	10000
0.25	10.5	200	0.8	133.7	BM10G06-../DHE07LA4	28	8000	10000
0.25	33	68	3.2	42.18	BM20-../DHE07LA4	26	12000	12000
0.25	26.5	85	2.5	52.84	BM20-../DHE07LA4	26	12000	12000
0.25	23	98	1.95	60.64	BM20-../DHE07LA4	26	12000	12000
0.25	18.5	122	1.5	74.76	BM20-../DHE07LA4	26	12000	12000
0.25	16.5	137	1.6	85.45	BM20Z-../DHE07LA4	27	12000	12000
0.25	14	162	1.35	99.47	BM20Z-../DHE07LA4	27	12000	12000
0.25	12	189	1.15	117.9	BM20Z-../DHE07LA4	27	12000	12000
0.25	9.7	230	0.96	142.8	BM20Z-../DHE07LA4	27	12000	12000
0.25	22.5	93	2.9	61.33	BM30-../DHE07LA4	41	12000	15000
0.25	19.5	107	2.4	71.09	BM30-../DHE07LA4	41	12000	15000
0.25	16	129	2.7	85.96	BM30Z-../DHE07LA4	44	12000	15000
0.25	14	146	2.4	100.7	BM30Z-../DHE07LA4	44	12000	15000
0.25	11	186	1.9	128.2	BM30Z-../DHE07LA4	44	12000	15000
0.25	9.2	220	1.6	150.3	BM30Z-../DHE07LA4	44	12000	15000
0.25	7.8	260	1.35	177.2	BM30Z-../DHE07LA4	44	12000	15000
0.25	7.4	290	1.2	186.7	BM30G06-../DHE07LA4	50	12000	15000
0.25	6.6	325	1.1	208.6	BM30G06-../DHE07LA4	50	12000	15000
0.25	5.7	375	0.93	245.1	BM30G06-../DHE07LA4	50	12000	15000
0.25	9.7	205	3.3	143.0	BM40Z-../DHE07LA4	66	20000	25000
0.25	8.2	240	2.8	169.0	BM40Z-../DHE07LA4	66	20000	25000
0.25	6.6	295	2.3	211.5	BM40Z-../DHE07LA4	66	20000	25000
0.25	5.6	345	1.95	246.6	BM40Z-../DHE07LA4	66	20000	25000

# Geared motors for electric overhead conveyors series BM

## Selection table asynchronous motors ASM IE2

### 0.25 kW

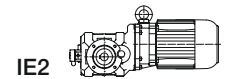

P <sub>N</sub> [kW]	50 Hz			i [:1]	Typ	m [kg]	F <sub>RN</sub> [N]	F <sub>RV</sub> [N]
	n <sub>2</sub> [1/min]	M <sub>2</sub> [Nm]	f <sub>B</sub> [-]					
0.25	4.8	400	1.5	289.8	BM40Z-../DHE07LA4	66	20000	25000
0.25	4.0	480	1.05	348.7	BM40Z-../DHE07LA4	66	20000	25000
0.25	3.2	590	0.85	430.0	BM40Z-../DHE07LA4	66	20000	25000
0.25	2.9	740	0.92	487.3	BM40G10-../DHE07LA4	71	20000	25000
0.25	2.6	820	0.83	540.0	BM40G10-../DHE07LA4	71	20000	25000

### 0.3 kW

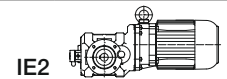

P <sub>N</sub> [kW]	50 Hz			i [:1]	Typ	m [kg]	F <sub>RN</sub> [N]	F <sub>RV</sub> [N]
	n <sub>2</sub> [1/min]	M <sub>2</sub> [Nm]	f <sub>B</sub> [-]					
0.3	120	21	1.45	11.34	BM09-../DHE07LA4	17	4400	6500
0.3	103	24	1.35	13.23	BM09-../DHE07LA4	17	4400	6500
0.3	77	32.5	1.45	17.73	BM09-../DHE07LA4	17	4400	6500
0.3	65	38.5	1.45	21.20	BM09-../DHE07LA4	17	4400	6500
0.3	55	45.5	1.3	24.74	BM09-../DHE07LA4	17	4400	6500
0.3	53	47.5	1.45	25.98	BM09-../DHE07LA4	17	4400	6500
0.3	45	56	1.3	30.31	BM09-../DHE07LA4	17	4400	6500
0.3	41.5	60	1.45	32.97	BM09-../DHE07LA4	17	4400	6500
0.3	35.5	71	1.3	38.46	BM09-../DHE07LA4	17	4400	6500
0.3	32.5	76	1.1	42.44	BM09-../DHE07LA4	17	4400	6500
0.3	25.5	97	1.1	53.85	BM09-../DHE07LA4	17	4400	6500
0.3	52	48	3.1	26.55	BM10-../DHE07LA4	23	8000	10000
0.3	46.5	54	3.0	29.45	BM10-../DHE07LA4	23	8000	10000
0.3	41	60	2.5	33.19	BM10-../DHE07LA4	23	8000	10000
0.3	37	66	2.4	36.82	BM10-../DHE07LA4	23	8000	10000
0.3	34	70	2.1	40.56	BM10-../DHE07LA4	23	8000	10000
0.3	30.5	78	2.1	45.00	BM10-../DHE07LA4	23	8000	10000
0.3	26	90	1.65	52.44	BM10-../DHE07LA4	23	8000	10000
0.3	23.5	99	1.6	58.18	BM10-../DHE07LA4	23	8000	10000
0.3	23.5	110	1.35	58.79	BM10G06-../DHE07LA4	28	8000	10000
0.3	20	130	1.1	69.61	BM10G06-../DHE07LA4	28	8000	10000
0.3	18.5	137	1.05	74.41	BM10G06-../DHE07LA4	28	8000	10000
0.3	16.5	154	1.0	82.54	BM10G06-../DHE07LA4	28	8000	10000
0.3	15	173	0.87	90.78	BM10G06-../DHE07LA4	28	8000	10000
0.3	13.5	186	0.81	102.7	BM10G06-../DHE07LA4	28	8000	10000
0.3	39	69	3.2	35.25	BM20-../DHE07LA4	26	12000	12000
0.3	32.5	83	2.7	42.18	BM20-../DHE07LA4	26	12000	12000
0.3	26	104	2.0	52.84	BM20-../DHE07LA4	26	12000	12000
0.3	22.5	120	1.6	60.64	BM20-../DHE07LA4	26	12000	12000
0.3	18.5	147	1.25	74.76	BM20-../DHE07LA4	26	12000	12000
0.3	16	170	1.3	85.45	BM20Z-../DHE07LA4	27	12000	12000
0.3	14	194	1.15	99.47	BM20Z-../DHE07LA4	27	12000	12000
0.3	12	225	0.98	117.9	BM20Z-../DHE07LA4	27	12000	12000
0.3	22.5	112	2.4	61.33	BM30-../DHE07LA4	41	12000	15000
0.3	19.5	129	2.0	71.09	BM30-../DHE07LA4	41	12000	15000
0.3	16	155	2.3	85.96	BM30Z-../DHE07LA4	44	12000	15000
0.3	14	175	2.0	100.7	BM30Z-../DHE07LA4	44	12000	15000
0.3	11	220	1.6	128.2	BM30Z-../DHE07LA4	44	12000	15000
0.3	9.1	265	1.3	150.3	BM30Z-../DHE07LA4	44	12000	15000
0.3	7.7	315	1.1	177.2	BM30Z-../DHE07LA4	44	12000	15000
0.3	7.3	350	1.0	186.7	BM30G06-../DHE07LA4	50	12000	15000
0.3	6.6	395	0.89	208.6	BM30G06-../DHE07LA4	50	12000	15000
0.3	9.6	250	2.7	143.0	BM40Z-../DHE07LA4	66	20000	25000
0.3	8.1	290	2.3	169.0	BM40Z-../DHE07LA4	66	20000	25000
0.3	6.5	360	1.9	211.5	BM40Z-../DHE07LA4	66	20000	25000
0.3	5.6	410	1.65	246.6	BM40Z-../DHE07LA4	66	20000	25000
0.3	4.7	490	1.2	289.8	BM40Z-../DHE07LA4	66	20000	25000
0.3	4.0	580	0.87	348.7	BM40Z-../DHE07LA4	66	20000	25000



# Geared motors for electric overhead conveyors series BM

## Selection table asynchronous motors ASM IE2

### 0.37 kW

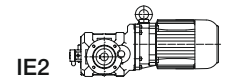

P <sub>N</sub> [kW]	50 Hz			i [:1]	Typ	m [kg]	F <sub>RN</sub> [N]	F <sub>RV</sub> [N]
	n <sub>2</sub> [1/min]	M <sub>2</sub> [Nm]	f <sub>B</sub> [-]					
0.37	127	24	1.25	11.34	BM09-../DHE08MA4	18	4400	6500
0.37	109	28.5	1.1	13.23	BM09-../DHE08MA4	18	4400	6500
0.37	81	38	1.25	17.73	BM09-../DHE08MA4	18	4400	6500
0.37	68	45.5	1.25	21.20	BM09-../DHE08MA4	18	4400	6500
0.37	58	53	1.1	24.74	BM09-../DHE08MA4	18	4400	6500
0.37	56	55	1.25	25.98	BM09-../DHE08MA4	18	4400	6500
0.37	47.5	65	1.1	30.31	BM09-../DHE08MA4	18	4400	6500
0.37	43.5	71	1.25	32.97	BM09-../DHE08MA4	18	4400	6500
0.37	37.5	82	1.1	38.46	BM09-../DHE08MA4	18	4400	6500
0.37	34	90	0.94	42.44	BM09-../DHE08MA4	18	4400	6500
0.37	27	113	0.96	53.85	BM09-../DHE08MA4	18	4400	6500
0.37	64	48.5	3.1	22.62	BM10-../DHE08MA4	24	8000	10000
0.37	57	54	3.0	25.09	BM10-../DHE08MA4	24	8000	10000
0.37	54	57	2.6	26.55	BM10-../DHE08MA4	24	8000	10000
0.37	49	63	2.5	29.45	BM10-../DHE08MA4	24	8000	10000
0.37	43.5	69	2.2	33.19	BM10-../DHE08MA4	24	8000	10000
0.37	39	77	2.1	36.82	BM10-../DHE08MA4	24	8000	10000
0.37	35.5	83	1.8	40.56	BM10-../DHE08MA4	24	8000	10000
0.37	32	92	1.75	45.00	BM10-../DHE08MA4	24	8000	10000
0.37	27.5	105	1.45	52.44	BM10-../DHE08MA4	24	8000	10000
0.37	25	115	1.4	58.18	BM10-../DHE08MA4	24	8000	10000
0.37	24.5	131	1.15	58.79	BM10G06-../DHE08MA4	33	8000	10000
0.37	21	153	0.92	69.61	BM10G06-../DHE08MA4	33	8000	10000
0.37	19.5	161	0.9	74.41	BM10G06-../DHE08MA4	33	8000	10000
0.37	17.5	179	0.87	82.54	BM10G06-../DHE08MA4	33	8000	10000
0.37	49	68	3.2	29.39	BM20-../DHE08MA4	26	12000	12000
0.37	41	81	2.7	35.25	BM20-../DHE08MA4	26	12000	12000
0.37	34	98	2.2	42.18	BM20-../DHE08MA4	26	12000	12000
0.37	27.5	122	1.7	52.84	BM20-../DHE08MA4	26	12000	12000
0.37	24	139	1.4	60.64	BM20-../DHE08MA4	26	12000	12000
0.37	19.5	172	1.05	74.76	BM20-../DHE08MA4	26	12000	12000
0.37	17	197	1.1	85.45	BM20Z-../DHE08MA4	28	12000	12000
0.37	14.5	230	0.96	99.47	BM20Z-../DHE08MA4	28	12000	12000
0.37	12.5	265	0.83	117.9	BM20Z-../DHE08MA4	28	12000	12000
0.37	29	108	2.9	49.66	BM30-../DHE08MA4	42	12000	15000
0.37	23.5	132	2.0	61.33	BM30-../DHE08MA4	42	12000	15000
0.37	20.5	151	1.7	71.09	BM30-../DHE08MA4	42	12000	15000
0.37	17	180	1.95	85.96	BM30Z-../DHE08MA4	45	12000	15000
0.37	14.5	205	1.7	100.7	BM30Z-../DHE08MA4	45	12000	15000
0.37	11.5	260	1.35	128.2	BM30Z-../DHE08MA4	45	12000	15000
0.37	9.6	310	1.15	150.3	BM30Z-../DHE08MA4	45	12000	15000
0.37	8.1	370	0.95	177.2	BM30Z-../DHE08MA4	45	12000	15000
0.37	7.7	410	0.85	186.7	BM30G06-../DHE08MA4	54	12000	15000
0.37	17	180	3.3	84.36	BM40-../DHE08MA4	63	20000	25000
0.37	14	210	2.9	104.0	BM40-../DHE08MA4	63	20000	25000
0.37	12.5	240	2.8	118.2	BM40Z-../DHE08MA4	67	20000	25000
0.37	10	295	2.3	143.0	BM40Z-../DHE08MA4	67	20000	25000
0.37	8.5	345	1.95	169.0	BM40Z-../DHE08MA4	67	20000	25000
0.37	6.8	425	1.6	211.5	BM40Z-../DHE08MA4	67	20000	25000
0.37	5.8	490	1.4	246.6	BM40Z-../DHE08MA4	67	20000	25000
0.37	5.0	570	1.05	289.8	BM40Z-../DHE08MA4	67	20000	25000

### 0.55 kW

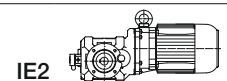

P <sub>N</sub> [kW]	50 Hz			i [:1]	Typ	m [kg]	F <sub>RN</sub> [N]	F <sub>RV</sub> [N]
	n <sub>2</sub> [1/min]	M <sub>2</sub> [Nm]	f <sub>B</sub> [-]					
0.55	125	36.5	0.82	11.34	BM09-../DHE08LA4	20	4400	6500
0.55	80	57	0.82	17.73	BM09-../DHE08LA4	20	4400	6500
0.55	67	68	0.82	21.20	BM09-../DHE08LA4	20	4400	6500
0.55	55	84	0.82	25.98	BM09-../DHE08LA4	20	4400	6500
0.55	43	107	0.81	32.97	BM09-../DHE08LA4	20	4400	6500
0.55	87	53	2.7	16.39	BM10-../DHE08LA4	26	8000	10000

# Geared motors for electric overhead conveyors series BM

## Selection table asynchronous motors ASM IE2

### 0.55 kW

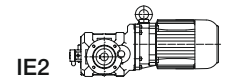

P <sub>N</sub> [kW]	50 Hz			i [:1]	Typ	m [kg]	F <sub>RN</sub> [N]	F <sub>RV</sub> [N]
	n <sub>2</sub> [1/min]	M <sub>2</sub> [Nm]	f <sub>B</sub> [-]					
0.55	78	59	2.6	18.18	BM10-../DHE08LA4	26	8000	10000
0.55	63	73	2.1	22.62	BM10-../DHE08LA4	26	8000	10000
0.55	57	81	2.0	25.09	BM10-../DHE08LA4	26	8000	10000
0.55	54	85	1.75	26.55	BM10-../DHE08LA4	26	8000	10000
0.55	48.5	95	1.7	29.45	BM10-../DHE08LA4	26	8000	10000
0.55	43	105	1.45	33.19	BM10-../DHE08LA4	26	8000	10000
0.55	38.5	117	1.35	36.82	BM10-../DHE08LA4	26	8000	10000
0.55	35	126	1.2	40.56	BM10-../DHE08LA4	26	8000	10000
0.55	31.5	140	1.15	45.00	BM10-../DHE08LA4	26	8000	10000
0.55	27	159	0.94	52.44	BM10-../DHE08LA4	26	8000	10000
0.55	24.5	175	0.91	58.18	BM10-../DHE08LA4	26	8000	10000
0.55	72	69	3.2	19.72	BM20-../DHE08LA4	28	12000	12000
0.55	57	87	2.5	25.25	BM20-../DHE08LA4	28	12000	12000
0.55	48.5	102	2.2	29.39	BM20-../DHE08LA4	28	12000	12000
0.55	40.5	123	1.8	35.25	BM20-../DHE08LA4	28	12000	12000
0.55	34	146	1.5	42.18	BM20-../DHE08LA4	28	12000	12000
0.55	27	184	1.15	52.84	BM20-../DHE08LA4	28	12000	12000
0.55	23.5	210	0.92	60.64	BM20-../DHE08LA4	28	12000	12000
0.55	21.5	230	0.96	66.74	BM20Z-../DHE08LA4	30	12000	12000
0.55	41	116	3.0	34.88	BM30-../DHE08LA4	44	12000	15000
0.55	34.5	137	2.6	41.13	BM30-../DHE08LA4	44	12000	15000
0.55	28.5	164	1.95	49.66	BM30-../DHE08LA4	44	12000	15000
0.55	23.5	196	1.4	61.33	BM30-../DHE08LA4	44	12000	15000
0.55	20	230	1.1	71.09	BM30-../DHE08LA4	44	12000	15000
0.55	16.5	275	1.25	85.96	BM30Z-../DHE08LA4	46	12000	15000
0.55	14.5	310	1.15	100.7	BM30Z-../DHE08LA4	46	12000	15000
0.55	11.5	390	0.9	128.2	BM30Z-../DHE08LA4	46	12000	15000
0.55	20.5	220	3.1	70.11	BM40-../DHE08LA4	64	20000	25000
0.55	17	265	2.3	84.36	BM40-../DHE08LA4	64	20000	25000
0.55	14	315	1.9	104.0	BM40-../DHE08LA4	64	20000	25000
0.55	12	370	1.85	118.2	BM40Z-../DHE08LA4	69	20000	25000
0.55	9.9	445	1.55	143.0	BM40Z-../DHE08LA4	69	20000	25000
0.55	8.4	510	1.35	169.0	BM40Z-../DHE08LA4	69	20000	25000
0.55	6.7	640	1.05	211.5	BM40Z-../DHE08LA4	69	20000	25000
0.55	5.8	730	0.93	246.6	BM40Z-../DHE08LA4	69	20000	25000

### 0.75 kW

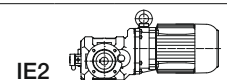

P <sub>N</sub> [kW]	50 Hz			i [:1]	Typ	m [kg]	F <sub>RN</sub> [N]	F <sub>RV</sub> [N]
	n <sub>2</sub> [1/min]	M <sub>2</sub> [Nm]	f <sub>B</sub> [-]					
0.75	122	53	2.6	11.68	BM10-../DHE08XA4	27	8000	10000
0.75	110	59	2.5	12.95	BM10-../DHE08XA4	27	8000	10000
0.75	87	73	2.0	16.39	BM10-../DHE08XA4	27	8000	10000
0.75	79	80	1.95	18.18	BM10-../DHE08XA4	27	8000	10000
0.75	63	100	1.5	22.62	BM10-../DHE08XA4	27	8000	10000
0.75	57	110	1.45	25.09	BM10-../DHE08XA4	27	8000	10000
0.75	54	116	1.3	26.55	BM10-../DHE08XA4	27	8000	10000
0.75	48.5	129	1.25	29.45	BM10-../DHE08XA4	27	8000	10000
0.75	43	143	1.05	33.19	BM10-../DHE08XA4	27	8000	10000
0.75	39	157	1.0	36.82	BM10-../DHE08XA4	27	8000	10000
0.75	35.5	169	0.89	40.56	BM10-../DHE08XA4	27	8000	10000
0.75	32	188	0.85	45.00	BM10-../DHE08XA4	27	8000	10000
0.75	85	80	2.8	16.72	BM20-../DHE08XA4	29	12000	12000
0.75	73	93	2.4	19.72	BM20-../DHE08XA4	29	12000	12000
0.75	57	119	1.85	25.25	BM20-../DHE08XA4	29	12000	12000
0.75	48.5	140	1.55	29.39	BM20-../DHE08XA4	29	12000	12000
0.75	40.5	168	1.3	35.25	BM20-../DHE08XA4	29	12000	12000
0.75	34	200	1.1	42.18	BM20-../DHE08XA4	29	12000	12000
0.75	27	250	0.84	52.84	BM20-../DHE08XA4	29	12000	12000
0.75	25.5	265	0.83	56.58	BM20Z-../DHE08XA4	31	12000	12000
0.75	61	106	3.3	23.38	BM30-../DHE08XA4	45	12000	15000
0.75	48	135	2.6	29.76	BM30-../DHE08XA4	45	12000	15000

# Geared motors for electric overhead conveyors series BM

## Selection table asynchronous motors ASM IE2

### 0.75 kW

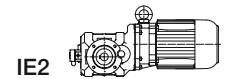

P <sub>N</sub> [kW]	n <sub>2</sub> [1/min]	50 Hz		i [:1]	Typ	m [kg]	F <sub>RN</sub> [N]	F <sub>RV</sub> [N]
		M <sub>2</sub> [Nm]	f <sub>B</sub> [—]					
0.75	41	158	2.2	34.88	BM30-../DHE08XA4	45	12000	15000
0.75	35	184	1.9	41.13	BM30-../DHE08XA4	45	12000	15000
0.75	29	215	1.45	49.66	BM30-../DHE08XA4	45	12000	15000
0.75	23.5	265	1.0	61.33	BM30-../DHE08XA4	45	12000	15000
0.75	20	315	0.82	71.09	BM30-../DHE08XA4	45	12000	15000
0.75	17	365	0.96	85.96	BM30Z-../DHE08XA4	48	12000	15000
0.75	14.5	420	0.83	100.7	BM30Z-../DHE08XA4	48	12000	15000
0.75	28	225	3.0	51.18	BM40-../DHE08XA4	65	20000	25000
0.75	24	260	2.6	59.66	BM40-../DHE08XA4	65	20000	25000
0.75	20.5	300	2.3	70.11	BM40-../DHE08XA4	65	20000	25000
0.75	17	365	1.65	84.36	BM40-../DHE08XA4	65	20000	25000
0.75	14	430	1.4	104.0	BM40-../DHE08XA4	65	20000	25000
0.75	12.5	485	1.4	118.2	BM40Z-../DHE08XA4	70	20000	25000
0.75	10	600	1.15	143.0	BM40Z-../DHE08XA4	70	20000	25000
0.75	8.5	690	0.99	169.0	BM40Z-../DHE08XA4	70	20000	25000

### 1.1 kW

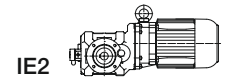

P <sub>N</sub> [kW]	n <sub>2</sub> [1/min]	50 Hz		i [:1]	Typ	m [kg]	F <sub>RN</sub> [N]	F <sub>RV</sub> [N]
		M <sub>2</sub> [Nm]	f <sub>B</sub> [—]					
1.1	124	77	1.8	11.68	BM10-../DHE09LA4	34	8000	10000
1.1	112	85	1.75	12.95	BM10-../DHE09LA4	34	8000	10000
1.1	88	106	1.35	16.39	BM10-../DHE09LA4	34	8000	10000
1.1	80	116	1.35	18.18	BM10-../DHE09LA4	34	8000	10000
1.1	64	144	1.05	22.62	BM10-../DHE09LA4	34	8000	10000
1.1	58	159	1.0	25.09	BM10-../DHE09LA4	34	8000	10000
1.1	55	168	0.89	26.55	BM10-../DHE09LA4	34	8000	10000
1.1	49	188	0.85	29.45	BM10-../DHE09LA4	34	8000	10000
1.1	142	70	3.1	10.15	BM20-../DHE09LA4	36	12000	12000
1.1	108	92	2.4	13.34	BM20-../DHE09LA4	36	12000	12000
1.1	87	114	1.95	16.72	BM20-../DHE09LA4	36	12000	12000
1.1	74	134	1.65	19.72	BM20-../DHE09LA4	36	12000	12000
1.1	58	172	1.3	25.25	BM20-../DHE09LA4	36	12000	12000
1.1	49	200	1.1	29.39	BM20-../DHE09LA4	36	12000	12000
1.1	41	240	0.92	35.25	BM20-../DHE09LA4	36	12000	12000
1.1	90	107	3.3	16.10	BM30-../DHE09LA4	52	12000	15000
1.1	73	132	2.7	19.96	BM30-../DHE09LA4	52	12000	15000
1.1	62	154	2.3	23.38	BM30-../DHE09LA4	52	12000	15000
1.1	48.5	197	1.8	29.76	BM30-../DHE09LA4	52	12000	15000
1.1	41.5	230	1.5	34.88	BM30-../DHE09LA4	52	12000	15000
1.1	35.5	265	1.3	41.13	BM30-../DHE09LA4	52	12000	15000
1.1	29	320	0.99	49.66	BM30-../DHE09LA4	52	12000	15000
1.1	27	335	0.84	53.67	BM30Z-../DHE09LA4	54	12000	15000
1.1	21	435	0.8	69.35	BM30Z-../DHE09LA4	54	12000	15000
1.1	42	225	3.0	34.61	BM40-../DHE09LA4	72	20000	25000
1.1	35.5	265	2.6	40.88	BM40-../DHE09LA4	72	20000	25000
1.1	28.5	320	2.1	51.18	BM40-../DHE09LA4	72	20000	25000
1.1	24.5	375	1.8	59.66	BM40-../DHE09LA4	72	20000	25000
1.1	21	435	1.55	70.11	BM40-../DHE09LA4	72	20000	25000
1.1	17.5	520	1.15	84.36	BM40-../DHE09LA4	72	20000	25000
1.1	14	630	0.95	104.0	BM40-../DHE09LA4	72	20000	25000
1.1	12.5	710	0.96	118.2	BM40Z-../DHE09LA4	76	20000	25000
1.1	10.5	840	0.81	143.0	BM40Z-../DHE09LA4	76	20000	25000

7

# Geared motors for electric overhead conveyors series BM

## Selection table asynchronous motors ASM IE2

### 1.5 kW

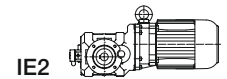

P <sub>N</sub> [kW]	50 Hz			i [:1]	Typ	m [kg]	F <sub>RN</sub> [N]	F <sub>RV</sub> [N]
	n <sub>2</sub> [1/min]	M <sub>2</sub> [Nm]	f <sub>B</sub> [—]					
1.5	124	105	1.35	11.68	BM10-../DHE09XA4	38	8000	10000
1.5	112	116	1.3	12.95	BM10-../DHE09XA4	38	8000	10000
1.5	88	144	1.0	16.39	BM10-../DHE09XA4	38	8000	10000
1.5	80	159	0.97	18.18	BM10-../DHE09XA4	38	8000	10000
1.5	188	72	2.8	7.66	BM20-../DHE09XA4	40	9100	10900
1.5	142	95	2.3	10.15	BM20-../DHE09XA4	40	12000	12000
1.5	108	126	1.75	13.34	BM20-../DHE09XA4	40	12000	12000
1.5	87	156	1.4	16.72	BM20-../DHE09XA4	40	12000	12000
1.5	74	183	1.2	19.72	BM20-../DHE09XA4	40	12000	12000
1.5	58	230	0.96	25.25	BM20-../DHE09XA4	40	12000	12000
1.5	49	275	0.8	29.39	BM20-../DHE09XA4	40	12000	12000
1.5	116	113	3.1	12.46	BM30-../DHE09XA4	56	12000	15000
1.5	90	146	2.4	16.10	BM30-../DHE09XA4	56	12000	15000
1.5	73	180	1.95	19.96	BM30-../DHE09XA4	56	12000	15000
1.5	62	210	1.65	23.38	BM30-../DHE09XA4	56	12000	15000
1.5	48.5	265	1.3	29.76	BM30-../DHE09XA4	56	12000	15000
1.5	41.5	310	1.15	34.88	BM30-../DHE09XA4	56	12000	15000
1.5	35.5	360	0.97	41.13	BM30-../DHE09XA4	56	12000	15000
1.5	51	250	2.7	28.59	BM40-../DHE09XA4	76	20000	25000
1.5	42	305	2.2	34.61	BM40-../DHE09XA4	76	20000	25000
1.5	35.5	360	1.9	40.88	BM40-../DHE09XA4	76	20000	25000
1.5	28.5	440	1.55	51.18	BM40-../DHE09XA4	76	20000	25000
1.5	24.5	510	1.35	59.66	BM40-../DHE09XA4	76	20000	25000
1.5	21	590	1.15	70.11	BM40-../DHE09XA4	76	20000	25000
1.5	17.5	710	0.85	84.36	BM40-../DHE09XA4	76	20000	25000

### 2.2 kW

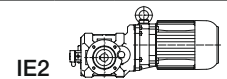

P <sub>N</sub> [kW]	50 Hz			i [:1]	Typ	m [kg]	F <sub>RN</sub> [N]	F <sub>RV</sub> [N]
	n <sub>2</sub> [1/min]	M <sub>2</sub> [Nm]	f <sub>B</sub> [—]					
2.2	122	156	0.9	11.68	BM10-../DHE09XB4	38	8000	10000
2.2	110	173	0.87	12.95	BM10-../DHE09XB4	38	8000	10000
2.2	186	107	1.85	7.66	BM20-../DHE09XB4	40	9100	10900
2.2	140	142	1.55	10.15	BM20-../DHE09XB4	40	12000	12000
2.2	107	186	1.2	13.34	BM20-../DHE09XB4	40	12000	12000
2.2	85	230	0.96	16.72	BM20-../DHE09XB4	40	12000	12000
2.2	73	270	0.81	19.72	BM20-../DHE09XB4	40	12000	12000
2.2	180	107	3.0	7.91	BM30-../DHE09XB4	56	11000	13800
2.2	142	136	2.6	10.06	BM30-../DHE09XB4	56	12000	15000
2.2	114	169	2.1	12.46	BM30-../DHE09XB4	56	12000	15000
2.2	89	215	1.65	16.10	BM30-../DHE09XB4	56	12000	15000
2.2	72	265	1.3	19.96	BM30-../DHE09XB4	56	12000	15000
2.2	61	310	1.15	23.38	BM30-../DHE09XB4	56	12000	15000
2.2	48	395	0.89	29.76	BM30-../DHE09XB4	56	12000	15000
2.2	79	235	2.9	18.05	BM40-../DHE09XB4	76	20000	25000
2.2	64	295	2.3	22.44	BM40-../DHE09XB4	76	20000	25000
2.2	50	375	1.8	28.59	BM40-../DHE09XB4	76	20000	25000
2.2	41.5	455	1.5	34.61	BM40-../DHE09XB4	76	20000	25000
2.2	35	540	1.25	40.88	BM40-../DHE09XB4	76	20000	25000
2.2	28	660	1.05	51.18	BM40-../DHE09XB4	76	20000	25000
2.2	24	770	0.88	59.66	BM40-../DHE09XB4	76	20000	25000

# Geared motors for electric overhead conveyors series BM

## Selection table asynchronous motors ASM IE2

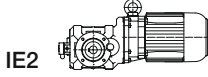
**3 kW** 

P <sub>N</sub> [kW]	n <sub>2</sub> [1/min]	50 Hz		i [:1]	Typ	m [kg]	F <sub>RN</sub> [N]	F <sub>RV</sub> [N]
		M <sub>2</sub> [Nm]	f <sub>B</sub> [—]					
3	183	144	2.2	7.91	BM30-../DHE11MA4	65	11000	13800
3	144	183	1.9	10.06	BM30-../DHE11MA4	65	12000	15000
3	116	225	1.55	12.46	BM30-../DHE11MA4	65	12000	15000
3	90	290	1.2	16.10	BM30-../DHE11MA4	65	12000	15000
3	73	360	0.97	19.96	BM30-../DHE11MA4	65	12000	15000
3	62	420	0.83	23.38	BM30-../DHE11MA4	65	12000	15000
3	129	199	3.1	11.17	BM40-../DHE11MA4	90	18300	22900
3	100	255	2.7	14.50	BM40-../DHE11MA4	90	20000	25000
3	80	320	2.1	18.05	BM40-../DHE11MA4	90	20000	25000
3	65	395	1.7	22.44	BM40-../DHE11MA4	90	20000	25000
3	51	500	1.35	28.59	BM40-../DHE11MA4	90	20000	25000
3	42	610	1.1	34.61	BM40-../DHE11MA4	90	20000	25000
3	35.5	720	0.94	40.88	BM40-../DHE11MA4	90	20000	25000

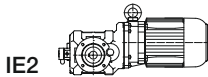
**4 kW** 

P <sub>N</sub> [kW]	n <sub>2</sub> [1/min]	50 Hz		i [:1]	Typ	m [kg]	F <sub>RN</sub> [N]	F <sub>RV</sub> [N]
		M <sub>2</sub> [Nm]	f <sub>B</sub> [—]					
4	183	192	1.7	7.91	BM30-../DHE11LA4	76	11000	13800
4	144	240	1.45	10.06	BM30-../DHE11LA4	76	12000	15000
4	116	300	1.15	12.46	BM30-../DHE11LA4	76	12000	15000
4	90	390	0.9	16.10	BM30-../DHE11LA4	76	12000	15000
4	129	265	2.4	11.17	BM40-../DHE11LA4	102	18300	22900
4	100	340	2.0	14.50	BM40-../DHE11LA4	102	20000	25000
4	80	425	1.6	18.05	BM40-../DHE11LA4	102	20000	25000
4	65	520	1.3	22.44	BM40-../DHE11LA4	102	20000	25000
4	51	670	1.0	28.59	BM40-../DHE11LA4	102	20000	25000
4	42	810	0.84	34.61	BM40-../DHE11LA4	102	20000	25000

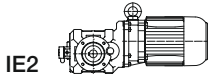
**5.5 kW** 

P <sub>N</sub> [kW]	n <sub>2</sub> [1/min]	50 Hz		i [:1]	Typ	m [kg]	F <sub>RN</sub> [N]	F <sub>RV</sub> [N]
		M <sub>2</sub> [Nm]	f <sub>B</sub> [—]					
5.5	184	260	1.25	7.91	BM30-../DHE11LB4	76	11000	13800
5.5	145	330	1.05	10.06	BM30-../DHE11LB4	76	12000	15000
5.5	117	410	0.85	12.46	BM30-../DHE11LB4	76	12000	15000
5.5	130	360	1.75	11.17	BM40-../DHE11LB4	102	18300	22900
5.5	100	470	1.45	14.50	BM40-../DHE11LB4	102	20000	25000
5.5	81	580	1.15	18.05	BM40-../DHE11LB4	102	20000	25000
5.5	65	720	0.94	22.44	BM40-../DHE11LB4	102	20000	25000

# Energy Efficient Geared Motors

## Electric overhead conveyors series BM

---

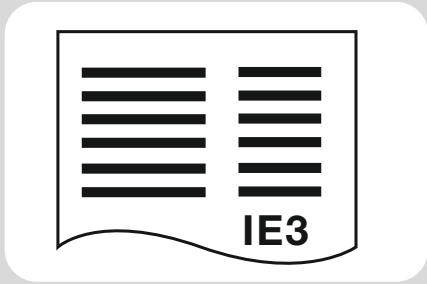

### Selection tables ASM IE2

Selection table asynchronous motors ASM IE2 .....77

# Energy Efficient Geared Motors

## Electric overhead conveyors series BM

---



# Geared motors for electric overhead conveyors series BM

## Selection table asynchronous motors ASM IE2

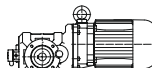
**0.03 kW** IE3 

P <sub>N</sub> [kW]	50 Hz			i [:1]	Typ	m [kg]	F <sub>RN</sub> [N]	F <sub>RV</sub> [N]
	n <sub>2</sub> [1/min]	M <sub>2</sub> [Nm]	f <sub>B</sub> [—]					
0.03	16.5	15.4	10	82.54	BM10G06-../D04LA4	23	8000	10000
0.03	15	17.3	8.7	90.78	BM10G06-../D04LA4	23	8000	10000
0.03	13.5	18.6	8.1	102.7	BM10G06-../D04LA4	23	8000	10000
0.03	11.5	21.5	7.0	120.5	BM10G06-../D04LA4	23	8000	10000
0.03	10.5	24	6.7	133.7	BM10G06-../D04LA4	23	8000	10000
0.03	9.0	27	5.6	150.7	BM10G06-../D04LA4	23	8000	10000
0.03	8.1	30	5.3	167.2	BM10G06-../D04LA4	23	8000	10000
0.03	7.2	35	4.3	189.8	BM10G06-../D04LA4	23	8000	10000
0.03	6.2	39.5	4.1	219.4	BM10G06-../D04LA4	23	8000	10000
0.03	5.3	46	3.5	258.1	BM10G06-../D04LA4	23	8000	10000
0.03	4.4	55	2.9	308.9	BM10G06-../D04LA4	23	8000	10000
0.03	4.0	61	2.6	345.4	BM10G06-../D04LA4	23	8000	10000
0.03	3.6	68	2.4	377.0	BM10G06-../D04LA4	23	8000	10000
0.03	3.3	74	2.2	415.3	BM10G06-../D04LA4	23	8000	10000
0.03	3.0	82	1.95	452.9	BM10G06-../D04LA4	23	8000	10000
0.03	2.5	98	1.65	544.2	BM10G06-../D04LA4	23	8000	10000
0.03	2.3	107	1.5	593.9	BM10G06-../D04LA4	23	8000	10000
0.03	2.0	123	1.3	698.8	BM10G06-../D04LA4	23	8000	10000
0.03	1.7	144	1.1	836.2	BM10G06-../D04LA4	23	8000	10000
0.03	1.5	164	0.98	938.2	BM10G06-../D04LA4	23	8000	10000
0.03	1.2	160*	1.0	1186	BM10G06-../D04LA4	23	8000	10000
0.03	0.95	160*	1.0	1482	BM10G06-../D04LA4	23	8000	10000
0.03	0.8	160*	1.0	1701	BM10G06-../D04LA4	23	8000	10000
0.03	0.7	160*	1.0	1935	BM10G06-../D04LA4	23	8000	10000
0.03	0.65	160*	1.0	2111	BM10G06-../D04LA4	23	8000	10000
0.03	0.6	160*	1.0	2254	BM10G06-../D04LA4	23	8000	10000
0.03	0.55	160*	1.0	2459	BM10G06-../D04LA4	23	8000	10000
0.03	2.1	122	2.9	663.4	BM30G06-../D04LA4	44	12000	15000
0.03	1.8	143	2.4	780.6	BM30G06-../D04LA4	44	12000	15000
0.03	1.5	171	2.0	934.1	BM30G06-../D04LA4	44	12000	15000
0.03	1.2	210	1.65	1143	BM30G06-../D04LA4	44	12000	15000
0.03	1.1	230	1.5	1325	BM30G06-../D04LA4	44	12000	15000
0.03	0.9	285	1.25	1518	BM30G06-../D04LA4	44	12000	15000
0.03	0.85	300	1.15	1656	BM30G06-../D04LA4	44	12000	15000
0.03	0.75	340	1.05	1900	BM30G06-../D04LA4	44	12000	15000
0.03	0.65	350*	1.0	2162	BM30G06-../D04LA4	44	12000	15000
0.03	0.6	350*	1.0	2358	BM30G06-../D04LA4	44	12000	15000
0.03	0.5	350*	1.0	2747	BM30G06-../D04LA4	44	12000	15000

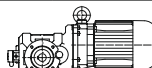
**0.04 kW** IE3 

P <sub>N</sub> [kW]	50 Hz			i [:1]	Typ	m [kg]	F <sub>RN</sub> [N]	F <sub>RV</sub> [N]
	n <sub>2</sub> [1/min]	M <sub>2</sub> [Nm]	f <sub>B</sub> [—]					
0.04	25.5	13.6	10	53.03	BM10G06-../D04LA4	23	8000	10000
0.04	23	15.1	9.9	58.79	BM10G06-../D04LA4	23	8000	10000
0.04	19.5	17.8	7.9	69.61	BM10G06-../D04LA4	23	8000	10000
0.04	18.5	18.3	7.9	74.41	BM10G06-../D04LA4	23	8000	10000
0.04	16.5	20.5	7.6	82.54	BM10G06-../D04LA4	23	8000	10000
0.04	15	23	6.5	90.78	BM10G06-../D04LA4	23	8000	10000
0.04	13.5	24.5	6.1	102.7	BM10G06-../D04LA4	23	8000	10000
0.04	11.5	29	5.2	120.5	BM10G06-../D04LA4	23	8000	10000
0.04	10.5	32	5.0	133.7	BM10G06-../D04LA4	23	8000	10000
0.04	9.0	36.5	4.1	150.7	BM10G06-../D04LA4	23	8000	10000
0.04	8.1	40.5	4.0	167.2	BM10G06-../D04LA4	23	8000	10000
0.04	7.2	46.5	3.2	189.8	BM10G06-../D04LA4	23	8000	10000
0.04	6.2	52	3.1	219.4	BM10G06-../D04LA4	23	8000	10000
0.04	5.3	61	2.6	258.1	BM10G06-../D04LA4	23	8000	10000
0.04	4.4	74	2.2	308.9	BM10G06-../D04LA4	23	8000	10000
0.04	4.0	82	1.95	345.4	BM10G06-../D04LA4	23	8000	10000
0.04	3.6	91	1.75	377.0	BM10G06-../D04LA4	23	8000	10000
0.04	3.3	99	1.6	415.3	BM10G06-../D04LA4	23	8000	10000
0.04	3.0	109	1.45	452.9	BM10G06-../D04LA4	23	8000	10000
0.04	2.5	131	1.2	544.2	BM10G06-../D04LA4	23	8000	10000
0.04	2.3	142	1.15	593.9	BM10G06-../D04LA4	23	8000	10000
0.04	2.0	164	0.98	698.8	BM10G06-../D04LA4	23	8000	10000
0.04	1.7	193	0.83	836.2	BM10G06-../D04LA4	23	8000	10000

# Geared motors for electric overhead conveyors series BM

## Selection table asynchronous motors ASM IE2

0.04 kW								
P <sub>N</sub>	50 Hz			i	Typ	m	F <sub>RN</sub>	F <sub>RV</sub>
	n <sub>2</sub>	M <sub>2</sub>	f <sub>B</sub>					
[kW]	[1/min]	[Nm]	[-]	[:1]		[kg]	[N]	[N]
0.04	5.4	67	2.7	253.0	BM20Z-../D04LA4	21	12000	12000
0.04	3.0	114	3.1	463.9	BM30G06-../D04LA4	44	12000	15000
0.04	2.6	132	2.7	533.9	BM30G06-../D04LA4	44	12000	15000
0.04	2.1	163	2.1	663.4	BM30G06-../D04LA4	44	12000	15000
0.04	1.8	191	1.85	780.6	BM30G06-../D04LA4	44	12000	15000
0.04	1.5	225	1.55	934.1	BM30G06-../D04LA4	44	12000	15000
0.04	1.2	285	1.25	1143	BM30G06-../D04LA4	44	12000	15000
0.04	1.1	310	1.15	1325	BM30G06-../D04LA4	44	12000	15000

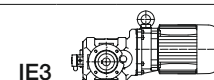

0.06 kW								
P <sub>N</sub>	50 Hz			i	Typ	m	F <sub>RN</sub>	F <sub>RV</sub>
	n <sub>2</sub>	M <sub>2</sub>	f <sub>B</sub>					
[kW]	[1/min]	[Nm]	[-]	[:1]		[kg]	[N]	[N]
0.06	33.5	14.3	10	40.56	BM10-../D06LA4	21	8000	10000
0.06	30	16	10	45.00	BM10-../D06LA4	21	8000	10000
0.06	26	18	8.3	52.44	BM10-../D06LA4	21	8000	10000
0.06	23.5	19.9	8.0	58.18	BM10-../D06LA4	21	8000	10000
0.06	10.5	48	3.3	133.7	BM10G06-../D06LA4	26	8000	10000
0.06	9.0	54	2.8	150.7	BM10G06-../D06LA4	26	8000	10000
0.06	8.1	60	2.7	167.2	BM10G06-../D06LA4	26	8000	10000
0.06	7.2	70	2.1	189.8	BM10G06-../D06LA4	26	8000	10000
0.06	6.2	79	2.0	219.4	BM10G06-../D06LA4	26	8000	10000
0.06	5.3	92	1.75	258.1	BM10G06-../D06LA4	26	8000	10000
0.06	4.4	111	1.45	308.9	BM10G06-../D06LA4	26	8000	10000
0.06	4.0	123	1.3	345.4	BM10G06-../D06LA4	26	8000	10000
0.06	3.6	136	1.2	377.0	BM10G06-../D06LA4	26	8000	10000
0.06	3.3	149	1.05	415.3	BM10G06-../D06LA4	26	8000	10000
0.06	3.0	164	0.98	452.9	BM10G06-../D06LA4	26	8000	10000
0.06	2.5	197	0.81	544.2	BM10G06-../D06LA4	26	8000	10000
0.06	7.6	71	2.9	178.9	BM20Z-../D06LA4	24	12000	12000
0.06	6.6	82	2.4	205.3	BM20Z-../D06LA4	24	12000	12000
0.06	5.4	100	1.8	253.0	BM20Z-../D06LA4	24	12000	12000
0.06	4.7	109	3.2	288.3	BM30G06-../D06LA4	47	12000	15000
0.06	4.0	128	2.7	345.1	BM30G06-../D06LA4	47	12000	15000
0.06	3.5	147	2.4	385.8	BM30G06-../D06LA4	47	12000	15000
0.06	3.0	171	2.0	463.9	BM30G06-../D06LA4	47	12000	15000
0.06	2.6	198	1.75	533.9	BM30G06-../D06LA4	47	12000	15000
0.06	2.1	245	1.45	663.4	BM30G06-../D06LA4	47	12000	15000
0.06	1.8	285	1.25	780.6	BM30G06-../D06LA4	47	12000	15000
0.06	1.5	340	1.05	934.1	BM30G06-../D06LA4	47	12000	15000
0.06	1.2	425	0.82	1143	BM30G06-../D06LA4	47	12000	15000
0.06	2.5	205	3.3	540.0	BM40G10-../D06LA4	68	20000	25000
0.06	2.1	245	2.8	660.2	BM40G10-../D06LA4	68	20000	25000
0.06	1.8	285	2.4	756.7	BM40G10-../D06LA4	68	20000	25000
0.06	1.7	300	2.3	838.4	BM40G10-../D06LA4	68	20000	25000
0.06	1.4	365	1.85	998.3	BM40G10-../D06LA4	68	20000	25000
0.06	1.2	425	1.6	1189	BM40G10-../D06LA4	68	20000	25000
0.06	0.95	540	1.25	1428	BM40G10-../D06LA4	68	20000	25000
0.06	0.8	640	1.05	1798	BM40G10-../D06LA4	68	20000	25000

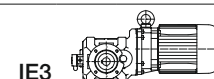

0.09 kW								
P <sub>N</sub>	50 Hz			i	Typ	m	F <sub>RN</sub>	F <sub>RV</sub>
	n <sub>2</sub>	M <sub>2</sub>	f <sub>B</sub>					
[kW]	[1/min]	[Nm]	[-]	[:1]		[kg]	[N]	[N]
0.09	51	14.8	10	26.55	BM10-../D06LA4	21	8000	10000
0.09	46	16.4	9.8	29.45	BM10-../D06LA4	21	8000	10000
0.09	41	18	8.3	33.19	BM10-../D06LA4	21	8000	10000
0.09	37	19.9	8.0	36.82	BM10-../D06LA4	21	8000	10000
0.09	33.5	21.5	7.0	40.56	BM10-../D06LA4	21	8000	10000

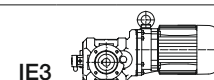

8

# Geared motors for electric overhead conveyors series BM

## Selection table asynchronous motors ASM IE2

### 0.09 kW

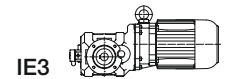

P <sub>N</sub> [kW]	50 Hz			i [:1]	Typ	m [kg]	F <sub>RN</sub> [N]	F <sub>RV</sub> [N]
	n <sub>2</sub> [1/min]	M <sub>2</sub> [Nm]	f <sub>B</sub> [—]					
0.09	30	24	6.7	45.00	BM10-../D06LA4	21	8000	10000
0.09	26	27	5.6	52.44	BM10-../D06LA4	21	8000	10000
0.09	23.5	29.5	5.4	58.18	BM10-../D06LA4	21	8000	10000
0.09	15	52	2.9	90.78	BM10G06-../D06LA4	26	8000	10000
0.09	13.5	56	2.7	102.7	BM10G06-../D06LA4	26	8000	10000
0.09	11.5	65	2.3	120.5	BM10G06-../D06LA4	26	8000	10000
0.09	10.5	72	2.2	133.7	BM10G06-../D06LA4	26	8000	10000
0.09	9.0	82	1.85	150.7	BM10G06-../D06LA4	26	8000	10000
0.09	8.1	91	1.75	167.2	BM10G06-../D06LA4	26	8000	10000
0.09	7.2	105	1.45	189.8	BM10G06-../D06LA4	26	8000	10000
0.09	6.2	119	1.35	219.4	BM10G06-../D06LA4	26	8000	10000
0.09	5.3	139	1.15	258.1	BM10G06-../D06LA4	26	8000	10000
0.09	4.4	167	0.96	308.9	BM10G06-../D06LA4	26	8000	10000
0.09	4.0	184	0.87	345.4	BM10G06-../D06LA4	26	8000	10000
0.09	11.5	71	3.1	117.9	BM20Z-../D06LA4	24	12000	12000
0.09	9.5	85	2.6	142.8	BM20Z-../D06LA4	24	12000	12000
0.09	7.6	107	1.95	178.9	BM20Z-../D06LA4	24	12000	12000
0.09	6.6	123	1.55	205.3	BM20Z-../D06LA4	24	12000	12000
0.09	5.4	151	1.2	253.0	BM20Z-../D06LA4	24	12000	12000
0.09	7.3	105	3.3	186.7	BM30G06-../D06LA4	47	12000	15000
0.09	6.5	120	2.9	208.6	BM30G06-../D06LA4	47	12000	15000
0.09	5.6	138	2.5	245.1	BM30G06-../D06LA4	47	12000	15000
0.09	4.7	164	2.1	288.3	BM30G06-../D06LA4	47	12000	15000
0.09	4.0	193	1.8	345.1	BM30G06-../D06LA4	47	12000	15000
0.09	3.5	220	1.6	385.8	BM30G06-../D06LA4	47	12000	15000
0.09	3.0	255	1.35	463.9	BM30G06-../D06LA4	47	12000	15000
0.09	2.6	295	1.2	533.9	BM30G06-../D06LA4	47	12000	15000
0.09	2.1	365	0.96	663.4	BM30G06-../D06LA4	47	12000	15000
0.09	1.8	425	0.82	780.6	BM30G06-../D06LA4	47	12000	15000
0.09	3.9	178	2.8	348.7	BM40Z-../D06LA4	64	20000	25000
0.09	3.2	210	2.4	430.0	BM40Z-../D06LA4	64	20000	25000
0.09	2.8	275	2.5	487.3	BM40G10-../D06LA4	68	20000	25000
0.09	2.5	305	2.2	540.0	BM40G10-../D06LA4	68	20000	25000
0.09	2.1	365	1.85	660.2	BM40G10-../D06LA4	68	20000	25000
0.09	1.8	425	1.6	756.7	BM40G10-../D06LA4	68	20000	25000
0.09	1.7	455	1.5	838.4	BM40G10-../D06LA4	68	20000	25000
0.09	1.4	550	1.25	998.3	BM40G10-../D06LA4	68	20000	25000
0.09	1.2	640	1.05	1189	BM40G10-../D06LA4	68	20000	25000

8

### 0.11 kW

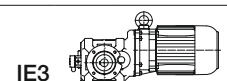

P <sub>N</sub> [kW]	50 Hz			i [:1]	Typ	m [kg]	F <sub>RN</sub> [N]	F <sub>RV</sub> [N]
	n <sub>2</sub> [1/min]	M <sub>2</sub> [Nm]	f <sub>B</sub> [—]					
0.11	31	30.5	4.6	44.15	BM10G06-../D04LA4	23	8000	10000
0.11	25.5	37	3.8	53.03	BM10G06-../D04LA4	23	8000	10000
0.11	23	41.5	3.6	58.79	BM10G06-../D04LA4	23	8000	10000
0.11	19.5	49	2.9	69.61	BM10G06-../D04LA4	23	8000	10000
0.11	18.5	50	2.9	74.41	BM10G06-../D04LA4	23	8000	10000
0.11	16.5	56	2.8	82.54	BM10G06-../D04LA4	23	8000	10000
0.11	15	63	2.4	90.78	BM10G06-../D04LA4	23	8000	10000
0.11	13.5	68	2.2	102.7	BM10G06-../D04LA4	23	8000	10000
0.11	11.5	80	1.9	120.5	BM10G06-../D04LA4	23	8000	10000
0.11	10.5	88	1.8	133.7	BM10G06-../D04LA4	23	8000	10000
0.11	9.0	100	1.5	150.7	BM10G06-../D04LA4	23	8000	10000
0.11	8.1	111	1.45	167.2	BM10G06-../D04LA4	23	8000	10000
0.11	7.2	128	1.15	189.8	BM10G06-../D04LA4	23	8000	10000
0.11	6.2	145	1.1	219.4	BM10G06-../D04LA4	23	8000	10000
0.11	5.3	170	0.94	258.1	BM10G06-../D04LA4	23	8000	10000
0.11	4.4	160*	1.0	308.9	BM10G06-../D04LA4	23	8000	10000
0.11	4.0	160*	1.0	345.4	BM10G06-../D04LA4	23	8000	10000
0.11	3.6	160*	1.0	377.0	BM10G06-../D04LA4	23	8000	10000
0.11	3.3	160*	1.0	415.3	BM10G06-../D04LA4	23	8000	10000
0.11	3.0	160*	1.0	452.9	BM10G06-../D04LA4	23	8000	10000
0.11	2.5	160*	1.0	544.2	BM10G06-../D04LA4	23	8000	10000

# Geared motors for electric overhead conveyors series BM

## Selection table asynchronous motors ASM IE2

### 0.11 kW

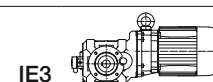

P <sub>N</sub> [kW]	50 Hz			i [:1]	Typ	m [kg]	F <sub>RN</sub> [N]	F <sub>RV</sub> [N]
	n <sub>2</sub> [1/min]	M <sub>2</sub> [Nm]	f <sub>B</sub> [-]					
0.11	2.3	160*	1.0	593.9	BM10G06-../D04LA4	23	8000	10000
0.11	2.0	160*	1.0	698.8	BM10G06-../D04LA4	23	8000	10000
0.11	1.7	160*	1.0	836.2	BM10G06-../D04LA4	23	8000	10000
0.11	1.5	160*	1.0	938.2	BM10G06-../D04LA4	23	8000	10000
0.11	1.2	160*	1.0	1186	BM10G06-../D04LA4	23	8000	10000
0.11	0.95	160*	1.0	1482	BM10G06-../D04LA4	23	8000	10000
0.11	0.8	160*	1.0	1701	BM10G06-../D04LA4	23	8000	10000
0.11	0.7	160*	1.0	1935	BM10G06-../D04LA4	23	8000	10000
0.11	0.65	160*	1.0	2111	BM10G06-../D04LA4	23	8000	10000
0.11	0.6	160*	1.0	2254	BM10G06-../D04LA4	23	8000	10000
0.11	0.55	160*	1.0	2459	BM10G06-../D04LA4	23	8000	10000
0.11	14	71	3.1	99.47	BM20Z-../D04LA4	21	12000	12000
0.11	11.5	86	2.6	117.9	BM20Z-../D04LA4	21	12000	12000
0.11	9.5	105	2.1	142.8	BM20Z-../D04LA4	21	12000	12000
0.11	7.6	131	1.6	178.9	BM20Z-../D04LA4	21	12000	12000
0.11	6.6	151	1.3	205.3	BM20Z-../D04LA4	21	12000	12000
0.11	5.4	184	0.99	253.0	BM20Z-../D04LA4	21	12000	12000
0.11	7.3	129	2.7	186.7	BM30G06-../D04LA4	44	12000	15000
0.11	6.5	147	2.4	208.6	BM30G06-../D04LA4	44	12000	15000
0.11	5.6	168	2.1	245.1	BM30G06-../D04LA4	44	12000	15000
0.11	4.7	200	1.75	288.3	BM30G06-../D04LA4	44	12000	15000
0.11	4.0	235	1.5	345.1	BM30G06-../D04LA4	44	12000	15000
0.11	3.5	270	1.3	385.8	BM30G06-../D04LA4	44	12000	15000
0.11	3.0	315	1.1	463.9	BM30G06-../D04LA4	44	12000	15000
0.11	2.6	360	0.97	533.9	BM30G06-../D04LA4	44	12000	15000
0.11	2.1	350*	1.0	663.4	BM30G06-../D04LA4	44	12000	15000
0.11	1.8	350*	1.0	780.6	BM30G06-../D04LA4	44	12000	15000
0.11	1.5	350*	1.0	934.1	BM30G06-../D04LA4	44	12000	15000
0.11	1.2	350*	1.0	1143	BM30G06-../D04LA4	44	12000	15000
0.11	1.1	350*	1.0	1325	BM30G06-../D04LA4	44	12000	15000
0.11	0.9	350*	1.0	1518	BM30G06-../D04LA4	44	12000	15000
0.11	0.85	350*	1.0	1656	BM30G06-../D04LA4	44	12000	15000
0.11	0.75	350*	1.0	1900	BM30G06-../D04LA4	44	12000	15000
0.11	0.65	350*	1.0	2162	BM30G06-../D04LA4	44	12000	15000
0.11	0.6	350*	1.0	2358	BM30G06-../D04LA4	44	12000	15000
0.11	0.5	350*	1.0	2747	BM30G06-../D04LA4	44	12000	15000

### 0.12 kW

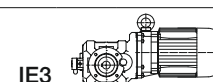

P <sub>N</sub> [kW]	50 Hz			i [:1]	Typ	m [kg]	F <sub>RN</sub> [N]	F <sub>RV</sub> [N]
	n <sub>2</sub> [1/min]	M <sub>2</sub> [Nm]	f <sub>B</sub> [-]					
0.12	124	8.1	3.7	11.34	BM09-../DPE05LA4	13	4400	6500
0.12	107	9.4	3.4	13.23	BM09-../DPE05LA4	13	4400	6500
0.12	80	12.6	3.7	17.73	BM09-../DPE05LA4	13	4400	6500
0.12	67	15	3.7	21.20	BM09-../DPE05LA4	13	4400	6500
0.12	57	17.6	3.4	24.74	BM09-../DPE05LA4	13	4400	6500
0.12	55	18.3	3.8	25.98	BM09-../DPE05LA4	13	4400	6500
0.12	46.5	21.5	3.3	30.31	BM09-../DPE05LA4	13	4400	6500
0.12	43	23	3.8	32.97	BM09-../DPE05LA4	13	4400	6500
0.12	37	27	3.4	38.46	BM09-../DPE05LA4	13	4400	6500
0.12	33.5	29.5	2.9	42.44	BM09-../DPE05LA4	13	4400	6500
0.12	26.5	37.5	2.9	53.85	BM09-../DPE05LA4	13	4400	6500
0.12	20.5	50	2.8	69.61	BM10G06-../DPE06LA4	26	8000	10000
0.12	19	53	2.7	74.41	BM10G06-../DPE06LA4	26	8000	10000
0.12	17	59	2.6	82.54	BM10G06-../DPE06LA4	26	8000	10000
0.12	15.5	67	2.2	90.78	BM10G06-../DPE06LA4	26	8000	10000
0.12	14	72	2.1	102.7	BM10G06-../DPE06LA4	26	8000	10000
0.12	12	84	1.8	120.5	BM10G06-../DPE06LA4	26	8000	10000
0.12	10.5	96	1.65	133.7	BM10G06-../DPE06LA4	26	8000	10000
0.12	9.3	105	1.45	150.7	BM10G06-../DPE06LA4	26	8000	10000
0.12	8.4	117	1.35	167.2	BM10G06-../DPE06LA4	26	8000	10000
0.12	7.4	136	1.1	189.8	BM10G06-../DPE06LA4	26	8000	10000
0.12	6.4	153	1.05	219.4	BM10G06-../DPE06LA4	26	8000	10000
0.12	5.5	179	0.89	258.1	BM10G06-../DPE06LA4	26	8000	10000

# Geared motors for electric overhead conveyors series BM

## Selection table asynchronous motors ASM IE2

0.12 kW

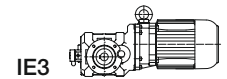

P <sub>N</sub> [kW]	50 Hz			i [:1]	Typ	m [kg]	F <sub>RN</sub> [N]	F <sub>RV</sub> [N]
	n <sub>2</sub> [1/min]	M <sub>2</sub> [Nm]	f <sub>B</sub> [-]					
0.12	4.6	160*	1.0	308.9	BM10G06-../DPE06LA4	26	8000	10000
0.12	4.1	160*	1.0	345.4	BM10G06-../DPE06LA4	26	8000	10000
0.12	3.8	160*	1.0	377.0	BM10G06-../DPE06LA4	26	8000	10000
0.12	3.4	160*	1.0	415.3	BM10G06-../DPE06LA4	26	8000	10000
0.12	3.1	160*	1.0	452.9	BM10G06-../DPE06LA4	26	8000	10000
0.12	2.6	160*	1.0	544.2	BM10G06-../DPE06LA4	26	8000	10000
0.12	2.4	160*	1.0	593.9	BM10G06-../DPE06LA4	26	8000	10000
0.12	2.1	160*	1.0	698.8	BM10G06-../DPE06LA4	26	8000	10000
0.12	1.7	160*	1.0	836.2	BM10G06-../DPE06LA4	26	8000	10000
0.12	1.5	160*	1.0	938.2	BM10G06-../DPE06LA4	26	8000	10000
0.12	1.2	160*	1.0	1186	BM10G06-../DPE06LA4	26	8000	10000
0.12	0.95	160*	1.0	1482	BM10G06-../DPE06LA4	26	8000	10000
0.12	0.85	160*	1.0	1701	BM10G06-../DPE06LA4	26	8000	10000
0.12	0.75	160*	1.0	1935	BM10G06-../DPE06LA4	26	8000	10000
0.12	0.7	160*	1.0	2111	BM10G06-../DPE06LA4	26	8000	10000
0.12	0.65	160*	1.0	2254	BM10G06-../DPE06LA4	26	8000	10000
0.12	0.6	160*	1.0	2459	BM10G06-../DPE06LA4	26	8000	10000
0.12	19	57	3.2	74.76	BM20-../DPE06LA4	23	12000	12000
0.12	14.5	75	2.9	99.47	BM20Z-../DPE06LA4	24	12000	12000
0.12	12	90	2.4	117.9	BM20Z-../DPE06LA4	24	12000	12000
0.12	9.9	109	2.0	142.8	BM20Z-../DPE06LA4	24	12000	12000
0.12	7.9	137	1.55	178.9	BM20Z-../DPE06LA4	24	12000	12000
0.12	6.9	157	1.25	205.3	BM20Z-../DPE06LA4	24	12000	12000
0.12	5.6	194	0.94	253.0	BM20Z-../DPE06LA4	24	12000	12000
0.12	8.0	121	2.9	177.2	BM30Z-../DPE06LA4	41	12000	15000
0.12	7.5	137	2.6	186.7	BM30G06-../DPE06LA4	47	12000	15000
0.12	6.8	153	2.3	208.6	BM30G06-../DPE06LA4	47	12000	15000
0.12	5.8	177	2.0	245.1	BM30G06-../DPE06LA4	47	12000	15000
0.12	4.9	210	1.65	288.3	BM30G06-../DPE06LA4	47	12000	15000
0.12	4.1	250	1.4	345.1	BM30G06-../DPE06LA4	47	12000	15000
0.12	3.7	275	1.25	385.8	BM30G06-../DPE06LA4	47	12000	15000
0.12	3.1	330	1.05	463.9	BM30G06-../DPE06LA4	47	12000	15000
0.12	2.7	380	0.92	533.9	BM30G06-../DPE06LA4	47	12000	15000
0.12	2.2	350*	1.0	663.4	BM30G06-../DPE06LA4	47	12000	15000
0.12	1.8	350*	1.0	780.6	BM30G06-../DPE06LA4	47	12000	15000
0.12	1.5	350*	1.0	934.1	BM30G06-../DPE06LA4	47	12000	15000
0.12	1.3	350*	1.0	1143	BM30G06-../DPE06LA4	47	12000	15000
0.12	1.1	350*	1.0	1325	BM30G06-../DPE06LA4	47	12000	15000
0.12	0.95	350*	1.0	1518	BM30G06-../DPE06LA4	47	12000	15000
0.12	0.85	350*	1.0	1656	BM30G06-../DPE06LA4	47	12000	15000
0.12	0.75	350*	1.0	1900	BM30G06-../DPE06LA4	47	12000	15000
0.12	0.65	350*	1.0	2162	BM30G06-../DPE06LA4	47	12000	15000
0.12	0.6	350*	1.0	2358	BM30G06-../DPE06LA4	47	12000	15000
0.12	0.55	350*	1.0	2747	BM30G06-../DPE06LA4	47	12000	15000
0.12	4.9	189	3.2	289.8	BM40Z-../DPE06LA4	64	20000	25000
0.12	4.1	225	2.3	348.7	BM40Z-../DPE06LA4	64	20000	25000
0.12	3.3	275	1.8	430.0	BM40Z-../DPE06LA4	64	20000	25000
0.12	2.9	355	1.9	487.3	BM40G10-../DPE06LA4	68	20000	25000
0.12	2.6	395	1.7	540.0	BM40G10-../DPE06LA4	68	20000	25000
0.12	2.2	465	1.45	660.2	BM40G10-../DPE06LA4	68	20000	25000
0.12	1.9	540	1.25	756.7	BM40G10-../DPE06LA4	68	20000	25000
0.12	1.7	600	1.15	838.4	BM40G10-../DPE06LA4	68	20000	25000
0.12	1.5	680	1.0	998.3	BM40G10-../DPE06LA4	68	20000	25000
0.12	1.2	850	0.8	1189	BM40G10-../DPE06LA4	68	20000	25000
0.12	1.0	680*	1.0	1428	BM40G10-../DPE06LA4	68	20000	25000
0.12	0.8	680*	1.0	1798	BM40G10-../DPE06LA4	68	20000	25000
0.12	0.7	680*	1.0	2108	BM40G10-../DPE06LA4	68	20000	25000
0.12	0.6	680*	1.0	2350	BM40G10-../DPE06LA4	68	20000	25000
0.12	0.55	680*	1.0	2604	BM40G10-../DPE06LA4	68	20000	25000
0.12	0.46	680*	1.0	3077	BM40G10-../DPE06LA4	68	20000	25000
0.12	0.41	680*	1.0	3429	BM40G10-../DPE06LA4	68	20000	25000
0.12	0.37	680*	1.0	3800	BM40G10-../DPE06LA4	68	20000	25000
0.12	0.33	680*	1.0	4363	BM40G10-../DPE06LA4	68	20000	25000



# Geared motors for electric overhead conveyors series BM

## Selection table asynchronous motors ASM IE2

### 0.18 kW

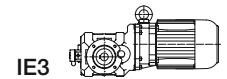

P <sub>N</sub> [kW]	50 Hz			i [:1]	Typ	m [kg]	F <sub>RN</sub> [N]	F <sub>RV</sub> [N]
	n <sub>2</sub> [1/min]	M <sub>2</sub> [Nm]	f <sub>B</sub> [—]					
0.18	124	12.1	2.5	11.34	BM09-../DPE07LA4	17	4400	6500
0.18	106	14.2	2.3	13.23	BM09-../DPE07LA4	17	4400	6500
0.18	79	19.1	2.5	17.73	BM09-../DPE07LA4	17	4400	6500
0.18	67	22.5	2.5	21.20	BM09-../DPE07LA4	17	4400	6500
0.18	57	26.5	2.2	24.74	BM09-../DPE07LA4	17	4400	6500
0.18	54	28	2.5	25.98	BM09-../DPE07LA4	17	4400	6500
0.18	46.5	32.5	2.2	30.31	BM09-../DPE07LA4	17	4400	6500
0.18	42.5	35.5	2.5	32.97	BM09-../DPE07LA4	17	4400	6500
0.18	36.5	41	2.2	38.46	BM09-../DPE07LA4	17	4400	6500
0.18	33	45	1.9	42.44	BM09-../DPE07LA4	17	4400	6500
0.18	26	57	1.9	53.85	BM09-../DPE07LA4	17	4400	6500
0.18	27	52	2.9	52.44	BM10-../DPE07LA4	23	8000	10000
0.18	24.5	57	2.8	58.18	BM10-../DPE07LA4	23	8000	10000
0.18	24	65	2.3	58.79	BM10G06-../DPE07LA4	28	8000	10000
0.18	20.5	76	1.85	69.61	BM10G06-../DPE07LA4	28	8000	10000
0.18	19	80	1.8	74.41	BM10G06-../DPE07LA4	28	8000	10000
0.18	17	89	1.75	82.54	BM10G06-../DPE07LA4	28	8000	10000
0.18	15.5	100	1.5	90.78	BM10G06-../DPE07LA4	28	8000	10000
0.18	14	108	1.4	102.7	BM10G06-../DPE07LA4	28	8000	10000
0.18	12	126	1.2	120.5	BM10G06-../DPE07LA4	28	8000	10000
0.18	10.5	144	1.1	133.7	BM10G06-../DPE07LA4	28	8000	10000
0.18	9.3	158	0.95	150.7	BM10G06-../DPE07LA4	28	8000	10000
0.18	8.4	175	0.91	167.2	BM10G06-../DPE07LA4	28	8000	10000
0.18	23.5	69	2.8	60.64	BM20-../DPE07LA4	26	12000	12000
0.18	19	85	2.1	74.76	BM20-../DPE07LA4	26	12000	12000
0.18	16.5	98	2.2	85.45	BM20Z-../DPE07LA4	27	12000	12000
0.18	14.5	112	1.95	99.47	BM20Z-../DPE07LA4	27	12000	12000
0.18	12	136	1.6	117.9	BM20Z-../DPE07LA4	27	12000	12000
0.18	9.9	164	1.35	142.8	BM20Z-../DPE07LA4	27	12000	12000
0.18	7.9	205	1.0	178.9	BM20Z-../DPE07LA4	27	12000	12000
0.18	6.9	235	0.82	205.3	BM20Z-../DPE07LA4	27	12000	12000
0.18	14	105	3.3	100.7	BM30Z-../DPE07LA4	44	12000	15000
0.18	11	134	2.6	128.2	BM30Z-../DPE07LA4	44	12000	15000
0.18	9.4	155	2.3	150.3	BM30Z-../DPE07LA4	44	12000	15000
0.18	8.0	182	1.9	177.2	BM30Z-../DPE07LA4	44	12000	15000
0.18	7.5	205	1.7	186.7	BM30G06-../DPE07LA4	50	12000	15000
0.18	6.8	230	1.5	208.6	BM30G06-../DPE07LA4	50	12000	15000
0.18	5.8	265	1.3	245.1	BM30G06-../DPE07LA4	50	12000	15000
0.18	4.9	315	1.1	288.3	BM30G06-../DPE07LA4	50	12000	15000
0.18	4.1	375	0.93	345.1	BM30G06-../DPE07LA4	50	12000	15000
0.18	3.7	415	0.84	385.8	BM30G06-../DPE07LA4	50	12000	15000
0.18	6.7	210	3.2	211.5	BM40Z-../DPE07LA4	66	20000	25000
0.18	5.7	240	2.8	246.6	BM40Z-../DPE07LA4	66	20000	25000
0.18	4.9	280	2.1	289.8	BM40Z-../DPE07LA4	66	20000	25000
0.18	4.1	335	1.5	348.7	BM40Z-../DPE07LA4	66	20000	25000
0.18	3.3	415	1.2	430.0	BM40Z-../DPE07LA4	66	20000	25000
0.18	2.9	530	1.3	487.3	BM40G10-../DPE07LA4	71	20000	25000
0.18	2.6	590	1.15	540.0	BM40G10-../DPE07LA4	71	20000	25000
0.18	2.2	700	0.97	660.2	BM40G10-../DPE07LA4	71	20000	25000
0.18	1.9	810	0.84	756.7	BM40G10-../DPE07LA4	71	20000	25000

### 0.25 kW

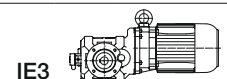

P <sub>N</sub> [kW]	50 Hz			i [:1]	Typ	m [kg]	F <sub>RN</sub> [N]	F <sub>RV</sub> [N]
	n <sub>2</sub> [1/min]	M <sub>2</sub> [Nm]	f <sub>B</sub> [—]					
0.25	127	16.5	1.8	11.34	BM09-../DPE08MA4	18	4400	6500
0.25	109	19.2	1.65	13.23	BM09-../DPE08MA4	18	4400	6500
0.25	82	25.5	1.85	17.73	BM09-../DPE08MA4	18	4400	6500
0.25	68	30.5	1.85	21.20	BM09-../DPE08MA4	18	4400	6500
0.25	59	35.5	1.65	24.74	BM09-../DPE08MA4	18	4400	6500
0.25	56	37.5	1.85	25.98	BM09-../DPE08MA4	18	4400	6500
0.25	48	43.5	1.65	30.31	BM09-../DPE08MA4	18	4400	6500
0.25	44	47.5	1.85	32.97	BM09-../DPE08MA4	18	4400	6500

# Geared motors for electric overhead conveyors series BM

## Selection table asynchronous motors ASM IE2

### 0.25 kW

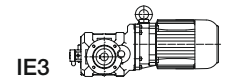

P <sub>N</sub> [kW]	50 Hz			i [:1]	Typ	m [kg]	F <sub>RN</sub> [N]	F <sub>RV</sub> [N]
	n <sub>2</sub> [1/min]	M <sub>2</sub> [Nm]	f <sub>B</sub> [-]					
0.25	37.5	56	1.65	38.46	BM09-../DPE08MA4	18	4400	6500
0.25	34	61	1.4	42.44	BM09-../DPE08MA4	18	4400	6500
0.25	27	76	1.4	53.85	BM09-../DPE08MA4	18	4400	6500
0.25	43.5	47	3.2	33.19	BM10-../DPE08MA4	24	8000	10000
0.25	39.5	51	3.1	36.82	BM10-../DPE08MA4	24	8000	10000
0.25	36	55	2.7	40.56	BM10-../DPE08MA4	24	8000	10000
0.25	32	62	2.6	45.00	BM10-../DPE08MA4	24	8000	10000
0.25	27.5	71	2.1	52.44	BM10-../DPE08MA4	24	8000	10000
0.25	25	78	2.1	58.18	BM10-../DPE08MA4	24	8000	10000
0.25	24.5	88	1.7	58.79	BM10G06-../DPE08MA4	33	8000	10000
0.25	21	103	1.35	69.61	BM10G06-../DPE08MA4	33	8000	10000
0.25	19.5	108	1.35	74.41	BM10G06-../DPE08MA4	33	8000	10000
0.25	17.5	121	1.3	82.54	BM10G06-../DPE08MA4	33	8000	10000
0.25	16	135	1.1	90.78	BM10G06-../DPE08MA4	33	8000	10000
0.25	14.5	144	1.05	102.7	BM10G06-../DPE08MA4	33	8000	10000
0.25	12	175	0.86	120.5	BM10G06-../DPE08MA4	33	8000	10000
0.25	11	191	0.84	133.7	BM10G06-../DPE08MA4	33	8000	10000
0.25	27.5	82	2.5	52.84	BM20-../DPE08MA4	26	12000	12000
0.25	24	94	2.1	60.64	BM20-../DPE08MA4	26	12000	12000
0.25	19.5	116	1.55	74.76	BM20-../DPE08MA4	26	12000	12000
0.25	17	133	1.65	85.45	BM20Z-../DPE08MA4	28	12000	12000
0.25	14.5	156	1.4	99.47	BM20Z-../DPE08MA4	28	12000	12000
0.25	12.5	181	1.2	117.9	BM20Z-../DPE08MA4	28	12000	12000
0.25	10.5	215	1.0	142.8	BM20Z-../DPE08MA4	28	12000	12000
0.25	23.5	89	3.0	61.33	BM30-../DPE08MA4	42	12000	15000
0.25	20.5	102	2.5	71.09	BM30-../DPE08MA4	42	12000	15000
0.25	17	122	2.9	85.96	BM30Z-../DPE08MA4	45	12000	15000
0.25	14.5	141	2.5	100.7	BM30Z-../DPE08MA4	45	12000	15000
0.25	11.5	178	1.95	128.2	BM30Z-../DPE08MA4	45	12000	15000
0.25	9.6	210	1.65	150.3	BM30Z-../DPE08MA4	45	12000	15000
0.25	8.2	245	1.45	177.2	BM30Z-../DPE08MA4	45	12000	15000
0.25	7.8	275	1.25	186.7	BM30G06-../DPE08MA4	54	12000	15000
0.25	7.0	310	1.15	208.6	BM30G06-../DPE08MA4	54	12000	15000
0.25	5.9	360	0.97	245.1	BM30G06-../DPE08MA4	54	12000	15000
0.25	5.0	425	0.82	288.3	BM30G06-../DPE08MA4	54	12000	15000
0.25	8.6	230	3.0	169.0	BM40Z-../DPE08MA4	67	20000	25000
0.25	6.9	280	2.4	211.5	BM40Z-../DPE08MA4	67	20000	25000
0.25	5.9	325	2.1	246.6	BM40Z-../DPE08MA4	67	20000	25000
0.25	5.0	385	1.55	289.8	BM40Z-../DPE08MA4	67	20000	25000
0.25	4.2	460	1.1	348.7	BM40Z-../DPE08MA4	67	20000	25000
0.25	3.4	560	0.89	430.0	BM40Z-../DPE08MA4	67	20000	25000
0.25	3.0	710	0.96	487.3	BM40G10-../DPE08MA4	72	20000	25000
0.25	2.7	790	0.86	540.0	BM40G10-../DPE08MA4	72	20000	25000

8

### 0.37 kW

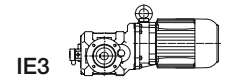

P <sub>N</sub> [kW]	50 Hz			i [:1]	Typ	m [kg]	F <sub>RN</sub> [N]	F <sub>RV</sub> [N]
	n <sub>2</sub> [1/min]	M <sub>2</sub> [Nm]	f <sub>B</sub> [-]					
0.37	128	24	1.25	11.34	BM09-../DPE08LA4	20	4400	6500
0.37	110	28	1.15	13.23	BM09-../DPE08LA4	20	4400	6500
0.37	82	37.5	1.25	17.73	BM09-../DPE08LA4	20	4400	6500
0.37	69	45	1.25	21.20	BM09-../DPE08LA4	20	4400	6500
0.37	59	52	1.15	24.74	BM09-../DPE08LA4	20	4400	6500
0.37	56	55	1.25	25.98	BM09-../DPE08LA4	20	4400	6500
0.37	48	64	1.15	30.31	BM09-../DPE08LA4	20	4400	6500
0.37	44	70	1.25	32.97	BM09-../DPE08LA4	20	4400	6500
0.37	38	81	1.15	38.46	BM09-../DPE08LA4	20	4400	6500
0.37	34.5	89	0.96	42.44	BM09-../DPE08LA4	20	4400	6500
0.37	27	113	0.96	53.85	BM09-../DPE08LA4	20	4400	6500
0.37	64	48.5	3.1	22.62	BM10-../DPE08LA4	26	8000	10000
0.37	58	53	3.0	25.09	BM10-../DPE08LA4	26	8000	10000
0.37	55	56	2.7	26.55	BM10-../DPE08LA4	26	8000	10000

# Geared motors for electric overhead conveyors series BM

## Selection table asynchronous motors ASM IE2

### 0.37 kW

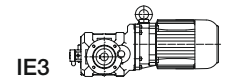

P <sub>N</sub> [kW]	50 Hz			i [:1]	Typ	m [kg]	F <sub>RN</sub> [N]	F <sub>RV</sub> [N]
	n <sub>2</sub> [1/min]	M <sub>2</sub> [Nm]	f <sub>B</sub> [—]					
0.37	49.5	62	2.6	29.45	BM10-../DPE08LA4	26	8000	10000
0.37	44	69	2.2	33.19	BM10-../DPE08LA4	26	8000	10000
0.37	39.5	76	2.1	36.82	BM10-../DPE08LA4	26	8000	10000
0.37	36	82	1.85	40.56	BM10-../DPE08LA4	26	8000	10000
0.37	32.5	91	1.75	45.00	BM10-../DPE08LA4	26	8000	10000
0.37	28	103	1.45	52.44	BM10-../DPE08LA4	26	8000	10000
0.37	25	115	1.4	58.18	BM10-../DPE08LA4	26	8000	10000
0.37	25	128	1.15	58.79	BM10G06-../DPE08LA4	34	8000	10000
0.37	21	153	0.92	69.61	BM10G06-../DPE08LA4	34	8000	10000
0.37	19.5	161	0.9	74.41	BM10G06-../DPE08LA4	34	8000	10000
0.37	18	174	0.89	82.54	BM10G06-../DPE08LA4	34	8000	10000
0.37	49.5	67	3.3	29.39	BM20-../DPE08LA4	28	12000	12000
0.37	41	81	2.7	35.25	BM20-../DPE08LA4	28	12000	12000
0.37	34.5	97	2.3	42.18	BM20-../DPE08LA4	28	12000	12000
0.37	27.5	122	1.7	52.84	BM20-../DPE08LA4	28	12000	12000
0.37	24	139	1.4	60.64	BM20-../DPE08LA4	28	12000	12000
0.37	19.5	172	1.05	74.76	BM20-../DPE08LA4	28	12000	12000
0.37	17	197	1.1	85.45	BM20Z-../DPE08LA4	30	12000	12000
0.37	15	220	1.0	99.47	BM20Z-../DPE08LA4	30	12000	12000
0.37	12.5	265	0.83	117.9	BM20Z-../DPE08LA4	30	12000	12000
0.37	29.5	106	3.0	49.66	BM30-../DPE08LA4	44	12000	15000
0.37	24	129	2.1	61.33	BM30-../DPE08LA4	44	12000	15000
0.37	20.5	151	1.7	71.09	BM30-../DPE08LA4	44	12000	15000
0.37	17	180	1.95	85.96	BM30Z-../DPE08LA4	46	12000	15000
0.37	14.5	205	1.7	100.7	BM30Z-../DPE08LA4	46	12000	15000
0.37	11.5	260	1.35	128.2	BM30Z-../DPE08LA4	46	12000	15000
0.37	9.7	305	1.15	150.3	BM30Z-../DPE08LA4	46	12000	15000
0.37	8.2	365	0.96	177.2	BM30Z-../DPE08LA4	46	12000	15000
0.37	7.8	405	0.86	186.7	BM30G06-../DPE08LA4	55	12000	15000
0.37	14	210	2.9	104.0	BM40-../DPE08LA4	64	20000	25000
0.37	12.5	240	2.8	118.2	BM40Z-../DPE08LA4	69	20000	25000
0.37	10.5	280	2.4	143.0	BM40Z-../DPE08LA4	69	20000	25000
0.37	8.6	340	2.0	169.0	BM40Z-../DPE08LA4	69	20000	25000
0.37	6.9	415	1.65	211.5	BM40Z-../DPE08LA4	69	20000	25000
0.37	5.9	485	1.4	246.6	BM40Z-../DPE08LA4	69	20000	25000
0.37	5.0	570	1.05	289.8	BM40Z-../DPE08LA4	69	20000	25000

### 0.55 kW

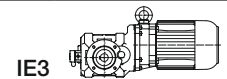

P <sub>N</sub> [kW]	50 Hz			i [:1]	Typ	m [kg]	F <sub>RN</sub> [N]	F <sub>RV</sub> [N]
	n <sub>2</sub> [1/min]	M <sub>2</sub> [Nm]	f <sub>B</sub> [—]					
0.55	127	36	0.83	11.34	BM09-../DPE08XA4	20	4400	6500
0.55	81	57	0.82	17.73	BM09-../DPE08XA4	20	4400	6500
0.55	68	67	0.84	21.20	BM09-../DPE08XA4	20	4400	6500
0.55	56	82	0.84	25.98	BM09-../DPE08XA4	20	4400	6500
0.55	43.5	106	0.82	32.97	BM09-../DPE08XA4	20	4400	6500
0.55	88	53	2.7	16.39	BM10-../DPE08XA4	27	8000	10000
0.55	79	59	2.6	18.18	BM10-../DPE08XA4	27	8000	10000
0.55	64	72	2.1	22.62	BM10-../DPE08XA4	27	8000	10000
0.55	57	81	2.0	25.09	BM10-../DPE08XA4	27	8000	10000
0.55	54	85	1.75	26.55	BM10-../DPE08XA4	27	8000	10000
0.55	49	94	1.7	29.45	BM10-../DPE08XA4	27	8000	10000
0.55	43.5	103	1.45	33.19	BM10-../DPE08XA4	27	8000	10000
0.55	39	115	1.4	36.82	BM10-../DPE08XA4	27	8000	10000
0.55	35.5	124	1.2	40.56	BM10-../DPE08XA4	27	8000	10000
0.55	32	137	1.15	45.00	BM10-../DPE08XA4	27	8000	10000
0.55	27.5	156	0.96	52.44	BM10-../DPE08XA4	27	8000	10000
0.55	25	172	0.93	58.18	BM10-../DPE08XA4	27	8000	10000
0.55	73	68	3.2	19.72	BM20-../DPE08XA4	29	12000	12000
0.55	57	87	2.5	25.25	BM20-../DPE08XA4	29	12000	12000
0.55	49	101	2.2	29.39	BM20-../DPE08XA4	29	12000	12000
0.55	41	121	1.8	35.25	BM20-../DPE08XA4	29	12000	12000



# Geared motors for electric overhead conveyors series BM

## Selection table asynchronous motors ASM IE2

### 0.55 kW

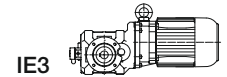

P <sub>N</sub> [kW]	50 Hz			i [:1]	Typ	m [kg]	F <sub>RN</sub> [N]	F <sub>RV</sub> [N]
	n <sub>2</sub> [1/min]	M <sub>2</sub> [Nm]	f <sub>B</sub> [—]					
0.55	34	146	1.5	42.18	BM20-../DPE08XA4	29	12000	12000
0.55	27.5	181	1.15	52.84	BM20-../DPE08XA4	29	12000	12000
0.55	24	205	0.94	60.64	BM20-../DPE08XA4	29	12000	12000
0.55	21.5	230	0.96	66.74	BM20Z-../DPE08XA4	31	12000	12000
0.55	41	116	3.0	34.88	BM30-../DPE08XA4	45	12000	15000
0.55	35	135	2.6	41.13	BM30-../DPE08XA4	45	12000	15000
0.55	29	161	1.95	49.66	BM30-../DPE08XA4	45	12000	15000
0.55	23.5	196	1.4	61.33	BM30-../DPE08XA4	45	12000	15000
0.55	20.5	225	1.15	71.09	BM30-../DPE08XA4	45	12000	15000
0.55	17	265	1.3	85.96	BM30Z-../DPE08XA4	48	12000	15000
0.55	14.5	310	1.15	100.7	BM30Z-../DPE08XA4	48	12000	15000
0.55	11.5	390	0.9	128.2	BM30Z-../DPE08XA4	48	12000	15000
0.55	20.5	220	3.1	70.11	BM40-../DPE08XA4	65	20000	25000
0.55	17	265	2.3	84.36	BM40-../DPE08XA4	65	20000	25000
0.55	14	315	1.9	104.0	BM40-../DPE08XA4	65	20000	25000
0.55	12.5	355	1.9	118.2	BM40Z-../DPE08XA4	70	20000	25000
0.55	10	440	1.55	143.0	BM40Z-../DPE08XA4	70	20000	25000
0.55	8.5	510	1.35	169.0	BM40Z-../DPE08XA4	70	20000	25000
0.55	6.8	630	1.1	211.5	BM40Z-../DPE08XA4	70	20000	25000
0.55	5.8	730	0.93	246.6	BM40Z-../DPE08XA4	70	20000	25000

### 0.75 kW

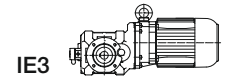

P <sub>N</sub> [kW]	50 Hz			i [:1]	Typ	m [kg]	F <sub>RN</sub> [N]	F <sub>RV</sub> [N]
	n <sub>2</sub> [1/min]	M <sub>2</sub> [Nm]	f <sub>B</sub> [—]					
0.75	123	52	2.7	11.68	BM10-../DPE08XB4	28	8000	10000
0.75	111	58	2.6	12.95	BM10-../DPE08XB4	28	8000	10000
0.75	87	73	2.0	16.39	BM10-../DPE08XB4	28	8000	10000
0.75	79	80	1.95	18.18	BM10-../DPE08XB4	28	8000	10000
0.75	63	100	1.5	22.62	BM10-../DPE08XB4	28	8000	10000
0.75	57	110	1.45	25.09	BM10-../DPE08XB4	28	8000	10000
0.75	54	116	1.3	26.55	BM10-../DPE08XB4	28	8000	10000
0.75	48.5	129	1.25	29.45	BM10-../DPE08XB4	28	8000	10000
0.75	43	143	1.05	33.19	BM10-../DPE08XB4	28	8000	10000
0.75	39	157	1.0	36.82	BM10-../DPE08XB4	28	8000	10000
0.75	35.5	169	0.89	40.56	BM10-../DPE08XB4	28	8000	10000
0.75	32	188	0.85	45.00	BM10-../DPE08XB4	28	8000	10000
0.75	86	79	2.8	16.72	BM20-../DPE08XB4	30	12000	12000
0.75	73	93	2.4	19.72	BM20-../DPE08XB4	30	12000	12000
0.75	57	119	1.85	25.25	BM20-../DPE08XB4	30	12000	12000
0.75	48.5	140	1.55	29.39	BM20-../DPE08XB4	30	12000	12000
0.75	40.5	168	1.3	35.25	BM20-../DPE08XB4	30	12000	12000
0.75	34	200	1.1	42.18	BM20-../DPE08XB4	30	12000	12000
0.75	27	250	0.84	52.84	BM20-../DPE08XB4	30	12000	12000
0.75	25.5	265	0.83	56.58	BM20Z-../DPE08XB4	31	12000	12000
0.75	61	106	3.3	23.38	BM30-../DPE08XB4	45	12000	15000
0.75	48	135	2.6	29.76	BM30-../DPE08XB4	45	12000	15000
0.75	41	158	2.2	34.88	BM30-../DPE08XB4	45	12000	15000
0.75	35	184	1.9	41.13	BM30-../DPE08XB4	45	12000	15000
0.75	29	215	1.45	49.66	BM30-../DPE08XB4	45	12000	15000
0.75	23.5	265	1.0	61.33	BM30-../DPE08XB4	45	12000	15000
0.75	20.5	305	0.85	71.09	BM30-../DPE08XB4	45	12000	15000
0.75	17	365	0.96	85.96	BM30Z-../DPE08XB4	48	12000	15000
0.75	14.5	420	0.83	100.7	BM30Z-../DPE08XB4	48	12000	15000
0.75	28	225	3.0	51.18	BM40-../DPE08XB4	66	20000	25000
0.75	24	260	2.6	59.66	BM40-../DPE08XB4	66	20000	25000
0.75	20.5	300	2.3	70.11	BM40-../DPE08XB4	66	20000	25000
0.75	17	365	1.65	84.36	BM40-../DPE08XB4	66	20000	25000
0.75	14	430	1.4	104.0	BM40-../DPE08XB4	66	20000	25000
0.75	12.5	485	1.4	118.2	BM40Z-../DPE08XB4	70	20000	25000
0.75	10	600	1.15	143.0	BM40Z-../DPE08XB4	70	20000	25000
0.75	8.5	690	0.99	169.0	BM40Z-../DPE08XB4	70	20000	25000

# Geared motors for electric overhead conveyors series BM

## Selection table asynchronous motors ASM IE2

### 1.1 kW

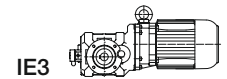

P <sub>N</sub> [kW]	50 Hz			i [:1]	Typ	m [kg]	F <sub>RN</sub> [N]	F <sub>RV</sub> [N]
	n <sub>2</sub> [1/min]	M <sub>2</sub> [Nm]	f <sub>B</sub> [—]					
1.1	124	77	1.8	11.68	BM10-../DPE09XA4	38	8000	10000
1.1	112	85	1.75	12.95	BM10-../DPE09XA4	38	8000	10000
1.1	88	106	1.35	16.39	BM10-../DPE09XA4	38	8000	10000
1.1	80	116	1.35	18.18	BM10-../DPE09XA4	38	8000	10000
1.1	64	144	1.05	22.62	BM10-../DPE09XA4	38	8000	10000
1.1	58	159	1.0	25.09	BM10-../DPE09XA4	38	8000	10000
1.1	55	168	0.89	26.55	BM10-../DPE09XA4	38	8000	10000
1.1	49	188	0.85	29.45	BM10-../DPE09XA4	38	8000	10000
1.1	142	70	3.1	10.15	BM20-../DPE09XA4	40	12000	12000
1.1	108	92	2.4	13.34	BM20-../DPE09XA4	40	12000	12000
1.1	87	114	1.95	16.72	BM20-../DPE09XA4	40	12000	12000
1.1	74	134	1.65	19.72	BM20-../DPE09XA4	40	12000	12000
1.1	58	172	1.3	25.25	BM20-../DPE09XA4	40	12000	12000
1.1	49	200	1.1	29.39	BM20-../DPE09XA4	40	12000	12000
1.1	41	240	0.92	35.25	BM20-../DPE09XA4	40	12000	12000
1.1	90	107	3.3	16.10	BM30-../DPE09XA4	56	12000	15000
1.1	73	132	2.7	19.96	BM30-../DPE09XA4	56	12000	15000
1.1	62	154	2.3	23.38	BM30-../DPE09XA4	56	12000	15000
1.1	48.5	197	1.8	29.76	BM30-../DPE09XA4	56	12000	15000
1.1	41.5	230	1.5	34.88	BM30-../DPE09XA4	56	12000	15000
1.1	35.5	265	1.3	41.13	BM30-../DPE09XA4	56	12000	15000
1.1	29	320	0.99	49.66	BM30-../DPE09XA4	56	12000	15000
1.1	27	335	0.84	53.67	BM30Z-../DPE09XA4	58	12000	15000
1.1	21	435	0.8	69.35	BM30Z-../DPE09XA4	58	12000	15000
1.1	42	225	3.0	34.61	BM40-../DPE09XA4	76	20000	25000
1.1	35.5	265	2.6	40.88	BM40-../DPE09XA4	76	20000	25000
1.1	28.5	320	2.1	51.18	BM40-../DPE09XA4	76	20000	25000
1.1	24.5	375	1.8	59.66	BM40-../DPE09XA4	76	20000	25000
1.1	21	435	1.55	70.11	BM40-../DPE09XA4	76	20000	25000
1.1	17.5	520	1.15	84.36	BM40-../DPE09XA4	76	20000	25000
1.1	14	630	0.95	104.0	BM40-../DPE09XA4	76	20000	25000
1.1	12.5	710	0.96	118.2	BM40Z-../DPE09XA4	80	20000	25000
1.1	10.5	840	0.81	143.0	BM40Z-../DPE09XA4	80	20000	25000

### 1.5 kW

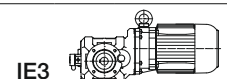

P <sub>N</sub> [kW]	50 Hz			i [:1]	Typ	m [kg]	F <sub>RN</sub> [N]	F <sub>RV</sub> [N]
	n <sub>2</sub> [1/min]	M <sub>2</sub> [Nm]	f <sub>B</sub> [—]					
1.5	123	105	1.35	11.68	BM10-../DPE09XB4	38	8000	10000
1.5	111	117	1.3	12.95	BM10-../DPE09XB4	38	8000	10000
1.5	88	144	1.0	16.39	BM10-../DPE09XB4	38	8000	10000
1.5	79	161	0.96	18.18	BM10-../DPE09XB4	38	8000	10000
1.5	188	72	2.8	7.66	BM20-../DPE09XB4	40	9100	10900
1.5	142	95	2.3	10.15	BM20-../DPE09XB4	40	12000	12000
1.5	108	126	1.75	13.34	BM20-../DPE09XB4	40	12000	12000
1.5	86	158	1.4	16.72	BM20-../DPE09XB4	40	12000	12000
1.5	73	186	1.2	19.72	BM20-../DPE09XB4	40	12000	12000
1.5	57	235	0.94	25.25	BM20-../DPE09XB4	40	12000	12000
1.5	49	275	0.8	29.39	BM20-../DPE09XB4	40	12000	12000
1.5	116	113	3.1	12.46	BM30-../DPE09XB4	56	12000	15000
1.5	90	146	2.4	16.10	BM30-../DPE09XB4	56	12000	15000
1.5	72	183	1.9	19.96	BM30-../DPE09XB4	56	12000	15000
1.5	62	210	1.65	23.38	BM30-../DPE09XB4	56	12000	15000
1.5	48.5	265	1.3	29.76	BM30-../DPE09XB4	56	12000	15000
1.5	41.5	310	1.15	34.88	BM30-../DPE09XB4	56	12000	15000
1.5	35	365	0.96	41.13	BM30-../DPE09XB4	56	12000	15000
1.5	51	250	2.7	28.59	BM40-../DPE09XB4	76	20000	25000
1.5	41.5	310	2.2	34.61	BM40-../DPE09XB4	76	20000	25000
1.5	35.5	360	1.9	40.88	BM40-../DPE09XB4	76	20000	25000
1.5	28.5	440	1.55	51.18	BM40-../DPE09XB4	76	20000	25000
1.5	24.5	510	1.35	59.66	BM40-../DPE09XB4	76	20000	25000

# Geared motors for electric overhead conveyors series BM

## Selection table asynchronous motors ASM IE2

### 1.5 kW

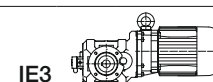

P <sub>N</sub> [kW]	n <sub>2</sub> [1/min]	50 Hz		i [:1]	Typ	m [kg]	F <sub>RN</sub> [N]	F <sub>RV</sub> [N]
		M <sub>2</sub> [Nm]	f <sub>B</sub> [—]					
1.5	20.5	600	1.15	70.11	BM40-../DPE09XB4	76	20000	25000
1.5	17.5	710	0.85	84.36	BM40-../DPE09XB4	76	20000	25000

### 2.2 kW

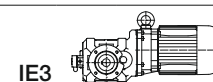

P <sub>N</sub> [kW]	n <sub>2</sub> [1/min]	50 Hz		i [:1]	Typ	m [kg]	F <sub>RN</sub> [N]	F <sub>RV</sub> [N]
		M <sub>2</sub> [Nm]	f <sub>B</sub> [—]					
2.2	125	152	0.92	11.68	BM10-../DPE09XB4C	38	8000	10000
2.2	112	170	0.88	12.95	BM10-../DPE09XB4C	38	8000	10000
2.2	190	105	1.9	7.66	BM20-../DPE09XB4C	40	9100	10900
2.2	143	139	1.6	10.15	BM20-../DPE09XB4C	40	12000	12000
2.2	109	183	1.2	13.34	BM20-../DPE09XB4C	40	12000	12000
2.2	87	225	0.98	16.72	BM20-../DPE09XB4C	40	12000	12000
2.2	74	265	0.83	19.72	BM20-../DPE09XB4C	40	12000	12000
2.2	184	105	3.1	7.91	BM30-../DPE09XB4C	56	11000	13800
2.2	145	133	2.6	10.06	BM30-../DPE09XB4C	56	12000	15000
2.2	117	165	2.1	12.46	BM30-../DPE09XB4C	56	12000	15000
2.2	91	210	1.65	16.10	BM30-../DPE09XB4C	56	12000	15000
2.2	73	260	1.35	19.96	BM30-../DPE09XB4C	56	12000	15000
2.2	63	300	1.15	23.38	BM30-../DPE09XB4C	56	12000	15000
2.2	49	390	0.9	29.76	BM30-../DPE09XB4C	56	12000	15000
2.2	81	230	3.0	18.05	BM40-../DPE09XB4C	76	20000	25000
2.2	65	290	2.3	22.44	BM40-../DPE09XB4C	76	20000	25000
2.2	51	370	1.85	28.59	BM40-../DPE09XB4C	76	20000	25000
2.2	42	450	1.5	34.61	BM40-../DPE09XB4C	76	20000	25000
2.2	35.5	530	1.3	40.88	BM40-../DPE09XB4C	76	20000	25000
2.2	28.5	640	1.05	51.18	BM40-../DPE09XB4C	76	20000	25000
2.2	24.5	750	0.91	59.66	BM40-../DPE09XB4C	76	20000	25000

### 3 kW

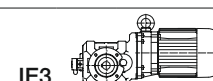

P <sub>N</sub> [kW]	n <sub>2</sub> [1/min]	50 Hz		i [:1]	Typ	m [kg]	F <sub>RN</sub> [N]	F <sub>RV</sub> [N]
		M <sub>2</sub> [Nm]	f <sub>B</sub> [—]					
3	184	143	2.3	7.91	BM30-../DPE11LA4	76	11000	13800
3	145	181	1.95	10.06	BM30-../DPE11LA4	76	12000	15000
3	117	225	1.55	12.46	BM30-../DPE11LA4	76	12000	15000
3	91	285	1.25	16.10	BM30-../DPE11LA4	76	12000	15000
3	73	360	0.97	19.96	BM30-../DPE11LA4	76	12000	15000
3	63	410	0.85	23.38	BM30-../DPE11LA4	76	12000	15000
3	131	196	3.2	11.17	BM40-../DPE11LA4	102	18300	22900
3	101	255	2.7	14.50	BM40-../DPE11LA4	102	20000	25000
3	81	315	2.2	18.05	BM40-../DPE11LA4	102	20000	25000
3	65	395	1.7	22.44	BM40-../DPE11LA4	102	20000	25000
3	51	500	1.35	28.59	BM40-../DPE11LA4	102	20000	25000
3	42.5	600	1.15	34.61	BM40-../DPE11LA4	102	20000	25000
3	36	710	0.96	40.88	BM40-../DPE11LA4	102	20000	25000

### 4 kW

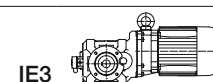

P <sub>N</sub> [kW]	n <sub>2</sub> [1/min]	50 Hz		i [:1]	Typ	m [kg]	F <sub>RN</sub> [N]	F <sub>RV</sub> [N]
		M <sub>2</sub> [Nm]	f <sub>B</sub> [—]					
4	184	191	1.7	7.91	BM30-../DPE11LB4	76	11000	13800
4	145	240	1.45	10.06	BM30-../DPE11LB4	76	12000	15000
4	117	300	1.15	12.46	BM30-../DPE11LB4	76	12000	15000
4	91	385	0.91	16.10	BM30-../DPE11LB4	76	12000	15000

# Geared motors for electric overhead conveyors series BM

## Selection table asynchronous motors ASM IE2

### 4 kW

IE3

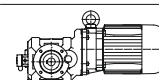

P <sub>N</sub> [kW]	n <sub>2</sub> [1/min]	50 Hz		i [:1]	Typ	m [kg]	F <sub>RN</sub> [N]	F <sub>RV</sub> [N]
		M <sub>2</sub> [Nm]	f <sub>B</sub> [—]					
4	130	260	2.4	11.17	BM40-../DPE11LB4	102	18300	22900
4	100	340	2.0	14.50	BM40-../DPE11LB4	102	20000	25000
4	81	420	1.6	18.05	BM40-../DPE11LB4	102	20000	25000
4	65	520	1.3	22.44	BM40-../DPE11LB4	102	20000	25000
4	51	670	1.0	28.59	BM40-../DPE11LB4	102	20000	25000
4	42	810	0.84	34.61	BM40-../DPE11LB4	102	20000	25000

### 5.5 kW

IE3

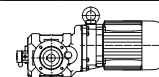

P <sub>N</sub> [kW]	n <sub>2</sub> [1/min]	50 Hz		i [:1]	Typ	m [kg]	F <sub>RN</sub> [N]	F <sub>RV</sub> [N]
		M <sub>2</sub> [Nm]	f <sub>B</sub> [—]					
5.5	186	255	1.25	7.91	BM30-../DPE11LB4C	80	11000	13800
5.5	146	330	1.05	10.06	BM30-../DPE11LB4C	80	12000	15000
5.5	118	405	0.86	12.46	BM30-../DPE11LB4C	80	12000	15000
5.5	132	355	1.75	11.17	BM40-../DPE11LB4C	106	18300	22900
5.5	102	460	1.5	14.50	BM40-../DPE11LB4C	106	20000	25000
5.5	82	570	1.2	18.05	BM40-../DPE11LB4C	106	20000	25000
5.5	66	710	0.96	22.44	BM40-../DPE11LB4C	106	20000	25000

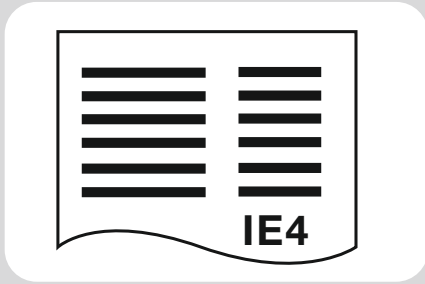

# 9

### Selection tables PMSM IE4

Selection table asynchronous motors PMSM - IE4 1500 <sup>1</sup> / <sub>min</sub> .....	91
Selection table asynchronous motors PMSM - IE4 3000 <sup>1</sup> / <sub>min</sub> .....	101

# Energy Efficient Geared Motors

## Electric overhead conveyors series BM

---

# Geared motors for electric overhead conveyors series BM

## Selection table asynchronous motors PMSM IE4 1500 1/ min

### MN = 0.76 Nm (PN = 0.12 kW)

IE4

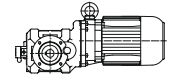

M <sub>N</sub> [Nm]	P <sub>N</sub> [kW]	n <sub>2</sub> [1/min]	M <sub>2</sub> [Nm]	f <sub>B</sub> [-]	i [1:1]	IE- Classe	Type	Speed range n <sub>2</sub> [1/min]					Torque range M <sub>2</sub> [Nm]					m [kg]	F <sub>RN</sub> [N]	F <sub>RV</sub> [N]
								at engine speed n <sub>1</sub> [1/min]					at engine speed n <sub>1</sub> [1/min]							
								150	500	1000	1500	1800	150	500	1000	1500	1800			
0.76	0.12	21.5	48	2.9	69.61	IE4	BM10G06-../S4E04SA4-1	2.1	7.1	14	21.5	25.5	48	48	48	48	48	23	8000	10000
0.76	0.12	20	50	2.9	74.41	IE4	BM10G06-../S4E04SA4-1	2	6.7	13	20	24	50	50	50	50	50	23	8000	10000
0.76	0.12	18	55	2.8	82.54	IE4	BM10G06-../S4E04SA4-1	1.8	6	12	18	21.5	55	55	55	55	55	23	8000	10000
0.76	0.12	16.5	62	2.4	90.78	IE4	BM10G06-../S4E04SA4-1	1.6	5.5	11	16.5	19.5	62	62	62	62	62	23	8000	10000
0.76	0.12	14.5	68	2.2	102.7	IE4	BM10G06-../S4E04SA4-1	1.4	4.8	9.7	14.5	17.5	68	68	68	68	68	23	8000	10000
0.76	0.12	12	80	1.9	120.5	IE4	BM10G06-../S4E04SA4-1	1.2	4.1	8.2	12	14.5	80	80	80	80	80	23	8000	10000
0.76	0.12	11	89	1.8	133.7	IE4	BM10G06-../S4E04SA4-1	1.1	3.7	7.4	11	13	89	89	89	89	89	23	8000	10000
0.76	0.12	9.9	98	1.5	150.7	IE4	BM10G06-../S4E04SA4-1	0.95	3.3	6.6	9.9	11.5	98	98	98	98	98	23	8000	10000
0.76	0.12	8.9	109	1.5	167.2	IE4	BM10G06-../S4E04SA4-1	0.85	2.9	5.9	8.9	10.5	109	109	109	109	109	23	8000	10000
0.76	0.12	7.9	126	1.2	189.8	IE4	BM10G06-../S4E04SA4-1	0.75	2.6	5.2	7.9	9.4	126	126	126	126	126	23	8000	10000
0.76	0.12	6.8	143	1.1	219.4	IE4	BM10G06-../S4E04SA4-1	0.65	2.2	4.5	6.8	8.2	143	143	143	143	143	23	8000	10000
0.76	0.12	5.8	168	0.95	258.1	IE4	BM10G06-../S4E04SA4-1	0.55	1.9	3.8	5.8	6.9	168	168	168	168	168	23	8000	10000
0.76	0.12	12.5	85	2.6	117.9	IE4	BM20Z-../S4E04SA4-1	1.2	4.2	8.4	12.5	15	85	85	85	85	85	21	12000	12000
0.76	0.12	10.5	103	2.1	142.8	IE4	BM20Z-../S4E04SA4-1	1	3.5	7	10.5	12.5	103	103	103	103	103	21	12000	12000
0.76	0.12	8.3	129	1.6	178.9	IE4	BM20Z-../S4E04SA4-1	0.8	2.7	5.5	8.3	10	129	129	129	129	129	21	12000	12000
0.76	0.12	7.3	148	1.3	205.3	IE4	BM20Z-../S4E04SA4-1	0.7	2.4	4.8	7.3	8.7	148	148	148	148	148	21	12000	12000
0.76	0.12	5.9	182	1	253	IE4	BM20Z-../S4E04SA4-1	0.55	1.9	3.9	5.9	7.1	182	182	182	182	182	21	12000	12000
0.76	0.12	8	127	2.7	186.7	IE4	BM30G06-../S4E04SA4-1	0.8	2.6	5.3	8	9.6	127	127	127	127	127	44	12000	15000
0.76	0.12	7.1	144	2.4	208.6	IE4	BM30G06-../S4E04SA4-1	0.7	2.3	4.7	7.1	8.6	144	144	144	144	144	44	12000	15000
0.76	0.12	6.1	167	2.1	245.1	IE4	BM30G06-../S4E04SA4-1	0.6	2	4	6.1	7.3	167	167	167	167	167	44	12000	15000
0.76	0.12	5.2	197	1.8	288.3	IE4	BM30G06-../S4E04SA4-1	0.5	1.7	3.4	5.2	6.2	197	197	197	197	197	44	12000	15000
0.76	0.12	4.3	235	1.5	345.1	IE4	BM30G06-../S4E04SA4-1	0.43	1.4	2.8	4.3	5.2	235	235	235	235	235	44	12000	15000
0.76	0.12	3.8	260	1.3	385.8	IE4	BM30G06-../S4E04SA4-1	0.38	1.2	2.5	3.8	4.6	260	260	260	260	260	44	12000	15000
0.76	0.12	3.2	315	1.1	463.9	IE4	BM30G06-../S4E04SA4-1	0.32	1	2.1	3.2	3.8	315	315	315	315	315	44	12000	15000
0.76	0.12	2.8	365	0.96	533.9	IE4	BM30G06-../S4E04SA4-1	0.28	0.9	1.8	2.8	3.3	365	365	365	365	365	44	12000	15000

### MN = 1 Nm (PN = 0.157 kW)

IE4

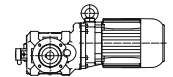

9

M <sub>N</sub> [Nm]	P <sub>N</sub> [kW]	n <sub>2</sub> [1/min]	M <sub>2</sub> [Nm]	f <sub>B</sub> [-]	i [1:1]	IE- Classe	Type	Speed range n <sub>2</sub> [1/min]					Torque range M <sub>2</sub> [Nm]					m [kg]	F <sub>RN</sub> [N]	F <sub>RV</sub> [N]
								at engine speed n <sub>1</sub> [1/min]					at engine speed n <sub>1</sub> [1/min]							
								150	500	1000	1500	1800	150	500	1000	1500	1800			
1	0.157	28	48	2.9	53.03	IE2	BM10G06-../SHE04SA4-1	2.8	9.4	18.5	28	33.5	36.5	41	48	48	48	23	8000	10000
1	0.157	25.5	53	2.8	58.79	IE2	BM10G06-../SHE04SA4-1	2.5	8.5	17	25.5	30.5	40.5	45	53	53	53	23	8000	10000
1	0.157	21.5	63	2.2	69.61	IE2	BM10G06-../SHE04SA4-1	2.1	7.1	14	21.5	25.5	48	53	63	63	63	23	8000	10000
1	0.157	20	66	2.2	74.41	IE2	BM10G06-../SHE04SA4-1	2	6.7	13	20	24	50	56	66	66	66	23	8000	10000
1	0.157	18	73	2.1	82.54	IE2	BM10G06-../SHE04SA4-1	1.8	6	12	18	21.5	55	62	73	73	73	23	8000	10000
1	0.157	16.5	82	1.8	90.78	IE2	BM10G06-../SHE04SA4-1	1.6	5.5	11	16.5	19.5	62	70	82	82	82	23	8000	10000
1	0.157	14.5	90	1.7	102.7	IE2	BM10G06-../SHE04SA4-1	1.4	4.8	9.7	14.5	17.5	68	76	90	90	90	23	8000	10000
1	0.157	12	106	1.4	120.5	IE2	BM10G06-../SHE04SA4-1	1.2	4.1	8.2	12	14.5	80	90	106	106	106	23	8000	10000
1	0.157	11	117	1.4	133.7	IE2	BM10G06-../SHE04SA4-1	1.1	3.7	7.4	11	13	89	100	117	117	117	23	8000	10000
1	0.157	9.9	129	1.2	150.7	IE2	BM10G06-../SHE04SA4-1	0.95	3.3	6.6	9.9	11.5	98	110	129	129	129	23	8000	10000
1	0.157	8.9	143	1.1	167.2	IE2	BM10G06-../SHE04SA4-1	0.85	2.9	5.9	8.9	10.5	109	122	143	143	143	23	8000	10000
1	0.157	7.9	167	0.9	189.8	IE2	BM10G06-../SHE04SA4-1	0.75	2.6	5.2	7.9	9.4	126	141	167	167	167	23	8000	10000
1	0.157	6.8	188	0.85	219.4	IE2	BM10G06-../SHE04SA4-1	0.65	2.2	4.5	6.8	8.2	143	160	188	188	188	23	8000	10000
1	0.157	17.5	81	2.7	85.45	IE2	BM20Z-../SHE04SA4-1	1.7	5.8	11.5	17.5	21	61	69	81	81	81	21	12000	12000
1	0.157	15	94	2.3	99.47	IE2	BM20Z-../SHE04SA4-1	1.5	5	10	15	18	71	80	94	94	94	21	12000	12000
1	0.157	12.5	112	2	117.9	IE2	BM20Z-../SHE04SA4-1	1.2	4.2	8.4	12.5	15	85	95	112	112	112	21	12000	12000
1	0.157	10.5	135	1.6	142.8	IE2	BM20Z-../SHE04SA4-1	1	3.5	7	10.5	12.5	103	115	135	135	135	21	12000	12000
1	0.157	8.3	169	1.2	178.9	IE2	BM20Z-../SHE04SA4-1	0.8	2.7	5.5	8.3	10	129	144	169	169	169	21	12000	12000
1	0.157	7.3	195	0.99	205.3	IE2	BM20Z-../SHE04SA4-1	0.7	2.4	4.8	7.3	8.7	148	165	195	195	195	21	12000	12000
1	0.157	8	168	2.1	186.7	IE2	BM30G06-../SHE04SA4-1	0.8	2.6	5.3	8	9.6	127	142	168	168	168	44	12000	15000
1	0.157	7.1	189	1.8	208.6	IE2	BM30G06-../SHE04SA4-1	0.7	2.3	4.7	7.1	8.6	144	161	189	189	189	44	12000	15000
1	0.157	6.1	220	1.6	245.1	IE2	BM30G06-../SHE04SA4-1	0.6	2	4	6.1	7.3	167	187	220	220	220	44	12000	15000
1	0.157	5.2	255	1.3	288.3	IE2	BM30G06-../SHE04SA4-1	0.5	1.7	3.4	5.2	6.2	197	220	255	255	255	44	12000	15000
1	0.157	4.3	310	1.1	345.1	IE2	BM30G06-../SHE04SA4-1	0.43	1.4	2.8	4.3	5.2	235	260	310	310	310	44	12000	15000
1	0.157	3.8	345	1	385.8	IE2	BM30G06-../SHE04SA4-1	0.38	1.2	2.5	3.8	4.6	260	295	345	345	345	44	12000	15000
1	0.157	3.2	415	0.84	463.9	IE2	BM30G06-../SHE04SA4-1	0.32	1	2.1	3.2	3.8	315	350	415	415	415	44	12000	15000

### MN = 1.3 Nm (PN = 0.2 kW)

IE4

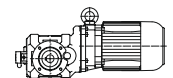

M <sub>N</sub> [Nm]	P <sub>N</sub> [kW]	n <sub>2</sub> [1/min]	M <sub>2</sub> [Nm]	f <sub>B</sub> [-]	i [1:1]	IE- Classe	Type	Speed range n <sub>2</sub> [1/min]					Torque range M <sub>2</sub> [Nm]					m [kg]	F <sub>RN</sub> [N]	F <sub>RV</sub> [N]
								at engine speed n <sub>1</sub> [1/min]					at engine speed n <sub>1</sub> [1/min]							
								150	500	1000	1500	1800	150	500	1000	1500	1800			
1.3	0.2	132	12.9	2.3	11.34	IE5	BM09-../S5E06MA4	13	44	88	132	158	12.9	12.9	12.9	12.9	12.9	14	4400	6500
1.3	0.2	113	15.1	2.1	13.23	IE5	BM09-../S5E06MA4	11	37.5	75	113	136	15.1	15.1	15.1	15.1	15.1	14	4400	6500
1.3	0.2	84	20	2.3	17.73	IE5	BM09-../S5E06MA4	8.4	28	56	84	101	20	20	20	20	20	14	4400	6500
1.3	0.2	70	24	2.3	21.2	IE5	BM09-../S5E06MA4	7	23.5	47	70	84	24	24	24	24	24	14	4400	6500
1.3	0.2	60	28	2.1	24.74	IE5	BM09-../S5E06MA4	6	20	40	60	72	28	28	28	28	28	14		



# Geared motors for electric overhead conveyors series BM

## Selection table asynchronous motors PMSM IE4 1500 1/min

**MN = 1.3 Nm (PN = 0.2 kW)**

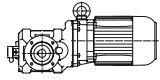

M <sub>N</sub> [Nm]	P <sub>N</sub> [kW]	n <sub>2</sub> [1/min]	M <sub>2</sub> [Nm]	f <sub>B</sub> [—]	i [:1]	IE- Classe	Type	Speed range n <sub>2</sub> [1/min]					Torque range M <sub>2</sub> [Nm]					m [kg]	F <sub>RN</sub> [N]	F <sub>RV</sub> [N]
								at engine speed n <sub>1</sub> [1/min]					at engine speed n <sub>1</sub> [1/min]							
								150	500	1000	1500	1800	150	500	1000	1500	1800			
1.3	0.2	57	29.5	2.3	25.98	IE5	BM09-../S5E06MA4	5.7	19	38	57	69	29.5	29.5	29.5	29.5	29.5	14	4400	6500
1.3	0.2	49	34.5	2.1	30.31	IE5	BM09-../S5E06MA4	4.9	16	32.5	49	59	34.5	34.5	34.5	34.5	34.5	14	4400	6500
1.3	0.2	45	37.5	2.3	32.97	IE5	BM09-../S5E06MA4	4.5	15	30	45	54	37.5	37.5	37.5	37.5	37.5	14	4400	6500
1.3	0.2	39	43.5	2.1	38.46	IE5	BM09-../S5E06MA4	3.9	13	26	39	46.5	43.5	43.5	43.5	43.5	43.5	14	4400	6500
1.3	0.2	35	47.5	1.8	42.44	IE5	BM09-../S5E06MA4	3.5	11.5	23.5	35	42	47.5	47.5	47.5	47.5	47.5	14	4400	6500
1.3	0.2	27.5	60	1.8	53.85	IE5	BM09-../S5E06MA4	2.7	9.2	18.5	27.5	33	60	60	60	60	60	14	4400	6500
1.3	0.2	28.5	55	2.7	52.44	IE5	BM10-../S5E06MA4	2.8	9.5	19	28.5	34	55	55	55	55	55	21	8000	10000
1.3	0.2	25.5	62	2.6	58.18	IE5	BM10-../S5E06MA4	2.5	8.5	17	25.5	30.5	62	62	62	62	62	21	8000	10000
1.3	0.2	33.5	52	2.7	44.15	IE5	BM10G06-../S5E06MA4	3.3	11	22.5	33.5	40.5	52	52	52	52	52	26	8000	10000
1.3	0.2	28	62	2.2	53.03	IE5	BM10G06-../S5E06MA4	2.8	9.4	18.5	28	33.5	62	62	62	62	62	26	8000	10000
1.3	0.2	25.5	69	2.2	58.79	IE5	BM10G06-../S5E06MA4	2.5	8.5	17	25.5	30.5	69	69	69	69	69	26	8000	10000
1.3	0.2	21.5	82	1.7	69.61	IE5	BM10G06-../S5E06MA4	2.1	7.1	14	21.5	25.5	82	82	82	82	82	26	8000	10000
1.3	0.2	20	86	1.7	74.41	IE5	BM10G06-../S5E06MA4	2	6.7	13	20	24	86	86	86	86	86	26	8000	10000
1.3	0.2	18	95	1.6	82.54	IE5	BM10G06-../S5E06MA4	1.8	6	12	18	21.5	95	95	95	95	95	26	8000	10000
1.3	0.2	16.5	107	1.4	90.78	IE5	BM10G06-../S5E06MA4	1.6	5.5	11	16.5	19.5	107	107	107	107	107	26	8000	10000
1.3	0.2	14.5	117	1.3	102.7	IE5	BM10G06-../S5E06MA4	1.4	4.8	9.7	14.5	17.5	117	117	117	117	117	26	8000	10000
1.3	0.2	12	137	1.1	120.5	IE5	BM10G06-../S5E06MA4	1.2	4.1	8.2	12	14.5	137	137	137	137	137	26	8000	10000
1.3	0.2	11	152	1	133.7	IE5	BM10G06-../S5E06MA4	1.1	3.7	7.4	11	13	152	152	152	152	152	26	8000	10000
1.3	0.2	9.9	168	0.89	150.7	IE5	BM10G06-../S5E06MA4	0.95	3.3	6.6	9.9	11.5	168	168	168	168	168	26	8000	10000
1.3	0.2	8.9	186	0.86	167.2	IE5	BM10G06-../S5E06MA4	0.85	2.9	5.9	8.9	10.5	186	186	186	186	186	26	8000	10000
1.3	0.2	24.5	74	2.6	60.64	IE5	BM20-../S5E06MA4	2.4	8.2	16	24.5	29.5	74	74	74	74	74	23	12000	12000
1.3	0.2	20	92	2	74.76	IE5	BM20-../S5E06MA4	2	6.6	13	20	24	92	92	92	92	92	23	12000	12000
1.3	0.2	22	82	2.7	66.74	IE5	BM20Z-../S5E06MA4	2.2	7.4	14.5	22	26.5	82	82	82	82	82	24	12000	12000
1.3	0.2	17.5	105	2.1	85.45	IE5	BM20Z-../S5E06MA4	1.7	5.8	11.5	17.5	21	105	105	105	105	105	24	12000	12000
1.3	0.2	15	122	1.8	99.47	IE5	BM20Z-../S5E06MA4	1.5	5	10	15	18	122	122	122	122	122	24	12000	12000
1.3	0.2	12.5	145	1.5	117.9	IE5	BM20Z-../S5E06MA4	1.2	4.2	8.4	12.5	15	145	145	145	145	145	24	12000	12000
1.3	0.2	10.5	176	1.2	142.8	IE5	BM20Z-../S5E06MA4	1	3.5	7	10.5	12.5	176	176	176	176	176	24	12000	12000
1.3	0.2	8.3	220	0.95	178.9	IE5	BM20Z-../S5E06MA4	0.8	2.7	5.5	8.3	10	220	220	220	220	220	24	12000	12000
1.3	0.2	11.5	143	2.4	128.2	IE5	BM30Z-../S5E06MA4	1.1	3.9	7.8	11.5	14	143	143	143	143	143	41	12000	15000
1.3	0.2	9.9	166	2.1	150.3	IE5	BM30Z-../S5E06MA4	0.95	3.3	6.6	9.9	11.5	166	166	166	166	166	41	12000	15000
1.3	0.2	8.4	195	1.8	177.2	IE5	BM30Z-../S5E06MA4	0.8	2.8	5.6	8.4	10	195	195	195	195	195	41	12000	15000
1.3	0.2	8	215	1.6	186.7	IE5	BM30G06-../S5E06MA4	0.8	2.6	5.3	8	9.6	215	215	215	215	215	47	12000	15000
1.3	0.2	7.1	245	1.4	208.6	IE5	BM30G06-../S5E06MA4	0.7	2.3	4.7	7.1	8.6	245	245	245	245	245	47	12000	15000
1.3	0.2	6.1	285	1.2	245.1	IE5	BM30G06-../S5E06MA4	0.6	2	4	6.1	7.3	285	285	285	285	285	47	12000	15000
1.3	0.2	5.2	335	1	288.3	IE5	BM30G06-../S5E06MA4	0.5	1.7	3.4	5.2	6.2	335	335	335	335	335	47	12000	15000
1.3	0.2	4.3	400	0.87	345.1	IE5	BM30G06-../S5E06MA4	0.43	1.4	2.8	4.3	5.2	400	400	400	400	400	47	12000	15000
1.3	0.2	7	225	3	211.5	IE5	BM40Z-../S5E06MA4	0.7	2.3	4.7	7	8.5	225	225	225	225	225	64	20000	25000
1.3	0.2	6	255	2.6	246.6	IE5	BM40Z-../S5E06MA4	0.6	2	4	6	7.2	255	255	255	255	255	64	20000	25000
1.3	0.2	5.1	305	1.9	289.8	IE5	BM40Z-../S5E06MA4	0.5	1.7	3.4	5.1	6.2	305	305	305	305	305	64	20000	25000
1.3	0.2	4.3	365	1.4	348.7	IE5	BM40Z-../S5E06MA4	0.43	1.4	2.8	4.3	5.1	365	365	365	365	365	64	20000	25000
1.3	0.2	3.4	445	1.1	430	IE5	BM40Z-../S5E06MA4	0.34	1.1	2.3	3.4	4.1	445	445	445	445	445	64	20000	25000
1.3	0.2	3	570	1.2	487.3	IE5	BM40G10-../S5E06MA4	0.3	1	2	3	3.6	570	570	570	570	570	68	20000	25000
1.3	0.2	2.7	630	1.1	540	IE5	BM40G10-../S5E06MA4	0.27	0.9	1.8	2.7	3.3	630	630	630	630	630	68	20000	25000
1.3	0.2	2.2	770	0.88	660.2	IE5	BM40G10-../S5E06MA4	0.22	0.75	1.5	2.2	2.7	770	770	770	770	770	68	20000	25000

9

**MN = 1.6 Nm (PN = 0.25 kW)**

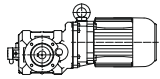

M <sub>N</sub> [Nm]	P <sub>N</sub> [kW]	n <sub>2</sub> [1/min]	M <sub>2</sub> [Nm]	f <sub>B</sub> [—]	i [:1]	IE- Classe	Type	Speed range n <sub>2</sub> [1/min]					Torque range M <sub>2</sub> [Nm]					m [kg]	F <sub>RN</sub> [N]	F <sub>RV</sub> [N]
								at engine speed n <sub>1</sub> [1/min]					at engine speed n <sub>1</sub> [1/min]							
								150	500	1000	1500	1800	150	500	1000	1500	1800			
1.6	0.25	132	15.9	1.9	11.34	IE4	BM09-../S4E06MA4	13	44	88	132	158	15.9	15.9	15.9	15.9	15.9	14	4400	6500
1.6	0.25	113	18.6	1.7	13.23	IE4	BM09-../S4E06MA4	11	37.5	75	113	136	18.6	18.6	18.6	18.6	18.6	14	4400	6500
1.6	0.25	84	24.5	1.9	17.73	IE4	BM09-../S4E06MA4	8.4	28	56	84	101	24.5	24.5	24.5	24.5	24.5	14	4400	6500
1.6	0.25	70	29.5	1.9	21.2	IE4	BM09-../S4E06MA4	7	23.5	47	70	84	29.5	29.5	29.5	29.5	29.5	14	4400	6500
1.6	0.25	60	34.5	1.7	24.74	IE4	BM09-../S4E06MA4	6	20	40	60	72	34.5	34.5	34.5	34.5	34.5	14	4400	6500
1.6	0.25	57	36.5	1.9	25.98	IE4	BM09-../S4E06MA4	5.7	19	38	57	69	36.5	36.5	36.5	36.5	36.5	14	4400	6500
1.6	0.25	49	42.5	1.7	30.31	IE4	BM09-../S4E06MA4	4.9	16	32.5	49	59	42.5	42.5	42.5	42.5	42.5	14	4400	6500
1.6	0.25	45	46	1.9	32.97	IE4	BM09-../S4E06MA4	4.5	15	30	45	54	46	46	46	46	46	14	4400	6500
1.6	0.25	39	54	1.7	38.46	IE4	BM09-../S4E06MA4	3.9	13	26	39	46.5	54	54	54	54	54	14	4400	6500
1.6	0.25	35	59	1.4	42.44	IE4	BM09-../S4E06MA4	3.5	11.5	23.5	35	42	59	59	59	59	59	14	4400	6500
1.6	0.25	27.5	74	1.4	53.85	IE4	BM09-../S4E06MA4	2.7	9.2	18.5	27.5	33	74	74	74	74	74	14	4400	6500
1.6	0.25	36.5	54	2.8	40.56	IE4	BM10-../S4E06MA4	3.6	12	24.5	36.5	44	54	54	54	54	54	21	8000	10000
1.6	0.25	33	60	2.6	45	IE4	BM10-../S4E06MA4	3.3	11	22	33	40	60	60	60	60	60	21	8000	10000
1.6	0.25	28.5	68	2.2	52.44	IE4	BM10-../S4E06MA4	2.8	9.5	19	28.5	34	68	68	68	68	68	21	8000	10000
1.6	0.25	25.5	76	2.1	58.18	IE4	BM10-../S4E06MA4	2.5	8.5	17	25.5	30.5	76	76	76	76	76	21	8000	10000
1.6	0.25	33.5	64	2.2	44.15	IE4	BM10G06-../S4E06MA4	3.3	11	22.5	33.5	40.5	64	64	64	64	64	26	8000	10000
1.6	0.25	28	77	1.8	53.03	IE4	BM10G06-../S4E06MA4	2.8	9.4	18.5	28	33.5	77	77	77	77	77	26	8	



# Geared motors for electric overhead conveyors series BM

## Selection table asynchronous motors PMSM IE4 1500 1/min

**MN = 1.6 Nm (PN = 0.25 kW)**

IE4

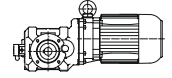

M <sub>N</sub>	P <sub>N</sub>	n <sub>2</sub>	M <sub>2</sub>	f <sub>B</sub>	i	IE-Classe	Type	Speed range n <sub>2</sub> [1/min]					Torque range M <sub>2</sub> [Nm]					m	F <sub>RN</sub>	F <sub>RV</sub>
								at engine speed n <sub>1</sub> [1/min]					at engine speed n <sub>1</sub> [1/min]							
								150	500	1000	1500	1800	150	500	1000	1500	1800			
1.6	0.25	14.5	144	1	102.7	IE4	BM10G06-../S4E06MA4	1.4	4.8	9.7	14.5	17.5	144	144	144	144	144	26	8000	10000
1.6	0.25	12	169	0.88	120.5	IE4	BM10G06-../S4E06MA4	1.2	4.1	8.2	12	14.5	169	169	169	169	169	26	8000	10000
1.6	0.25	11	188	0.85	133.7	IE4	BM10G06-../S4E06MA4	1.1	3.7	7.4	11	13	188	188	188	188	188	26	8000	10000
1.6	0.25	28	80	2.6	52.84	IE4	BM20-../S4E06MA4	2.8	9.4	18.5	28	34	80	80	80	80	80	23	12000	12000
1.6	0.25	24.5	92	2.1	60.64	IE4	BM20-../S4E06MA4	2.4	8.2	16	24.5	29.5	92	92	92	92	92	23	12000	12000
1.6	0.25	20	113	1.6	74.76	IE4	BM20-../S4E06MA4	2	6.6	13	20	24	113	113	113	113	113	23	12000	12000
1.6	0.25	22	101	2.2	66.74	IE4	BM20Z-../S4E06MA4	2.2	7.4	14.5	22	26.5	101	101	101	101	101	24	12000	12000
1.6	0.25	17.5	129	1.7	85.45	IE4	BM20Z-../S4E06MA4	1.7	5.8	11.5	17.5	21	129	129	129	129	129	24	12000	12000
1.6	0.25	15	151	1.5	99.47	IE4	BM20Z-../S4E06MA4	1.5	5	10	15	18	151	151	151	151	151	24	12000	12000
1.6	0.25	12.5	179	1.2	117.9	IE4	BM20Z-../S4E06MA4	1.2	4.2	8.4	12.5	15	179	179	179	179	179	24	12000	12000
1.6	0.25	10.5	215	1	142.8	IE4	BM20Z-../S4E06MA4	1	3.5	7	10.5	12.5	215	215	215	215	215	24	12000	12000
1.6	0.25	21	100	2.5	71.09	IE4	BM30-../S4E06MA4	2.1	7	14	21	25	100	100	100	100	100	39	12000	15000
1.6	0.25	17	119	2.9	85.96	IE4	BM30Z-../S4E06MA4	1.7	5.8	11.5	17	20.5	119	119	119	119	119	41	12000	15000
1.6	0.25	14.5	138	2.5	100.7	IE4	BM30Z-../S4E06MA4	1.4	4.9	9.9	14.5	17.5	138	138	138	138	138	41	12000	15000
1.6	0.25	11.5	176	2	128.2	IE4	BM30Z-../S4E06MA4	1.1	3.9	7.8	11.5	14	176	176	176	176	176	41	12000	15000
1.6	0.25	9.9	200	1.7	150.3	IE4	BM30Z-../S4E06MA4	0.95	3.3	6.6	9.9	11.5	200	200	200	200	200	41	12000	15000
1.6	0.25	8.4	240	1.5	177.2	IE4	BM30Z-../S4E06MA4	0.8	2.8	5.6	8.4	10	240	240	240	240	240	41	12000	15000
1.6	0.25	8	265	1.3	186.7	IE4	BM30G06-../S4E06MA4	0.8	2.6	5.3	8	9.6	265	265	265	265	265	47	12000	15000
1.6	0.25	7.1	300	1.2	208.6	IE4	BM30G06-../S4E06MA4	0.7	2.3	4.7	7.1	8.6	300	300	300	300	300	47	12000	15000
1.6	0.25	6.1	350	0.99	245.1	IE4	BM30G06-../S4E06MA4	0.6	2	4	6.1	7.3	350	350	350	350	350	47	12000	15000
1.6	0.25	5.2	415	0.84	288.3	IE4	BM30G06-../S4E06MA4	0.5	1.7	3.4	5.2	6.2	415	415	415	415	415	47	12000	15000
1.6	0.25	8.8	220	3	169	IE4	BM40Z-../S4E06MA4	0.85	2.9	5.9	8.8	10.5	220	220	220	220	220	64	20000	25000
1.6	0.25	7	275	2.5	211.5	IE4	BM40Z-../S4E06MA4	0.7	2.3	4.7	7	8.5	275	275	275	275	275	64	20000	25000
1.6	0.25	6	315	2.1	246.6	IE4	BM40Z-../S4E06MA4	0.6	2	4	6	7.2	315	315	315	315	315	64	20000	25000
1.6	0.25	5.1	375	1.6	289.8	IE4	BM40Z-../S4E06MA4	0.5	1.7	3.4	5.1	6.2	375	375	375	375	375	64	20000	25000
1.6	0.25	4.3	450	1.1	348.7	IE4	BM40Z-../S4E06MA4	0.43	1.4	2.8	4.3	5.1	450	450	450	450	450	64	20000	25000
1.6	0.25	3.4	550	0.91	430	IE4	BM40Z-../S4E06MA4	0.34	1.1	2.3	3.4	4.1	550	550	550	550	550	64	20000	25000
1.6	0.25	3	700	0.97	487.3	IE4	BM40G10-../S4E06MA4	0.3	1	2	3	3.6	700	700	700	700	700	68	20000	25000
1.6	0.25	2.7	770	0.87	540	IE4	BM40G10-../S4E06MA4	0.27	0.9	1.8	2.7	3.3	770	770	770	770	770	68	20000	25000

**MN = 2.4 Nm (PN = 0.37 kW)**

IE4

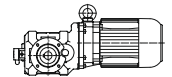

M <sub>N</sub>	P <sub>N</sub>	n <sub>2</sub>	M <sub>2</sub>	f <sub>B</sub>	i	IE-Classe	Type	Speed range n <sub>2</sub> [1/min]					Torque range M <sub>2</sub> [Nm]					m	F <sub>RN</sub>	F <sub>RV</sub>
								at engine speed n <sub>1</sub> [1/min]					at engine speed n <sub>1</sub> [1/min]							
								150	500	1000	1500	1800	150	500	1000	1500	1800			
2.4	0.37	132	23.5	1.3	11.34	IE4	BM09-../S4E06LA4	13	44	88	132	158	23.5	23.5	23.5	23.5	23.5	14	4400	6500
2.4	0.37	132	23.5	1.3	11.34	IE1	BM09-../SSE06MA4	13	44	88	132	158	17.9	19.9	21.5	23.5	23.5	14	4400	6500
2.4	0.37	113	27.5	1.1	13.23	IE4	BM09-../S4E06LA4	11	37.5	75	113	136	27.5	27.5	27.5	27.5	27.5	14	4400	6500
2.4	0.37	113	27.5	1.1	13.23	IE1	BM09-../SSE06MA4	11	37.5	75	113	136	20.5	23	25.5	27.5	27.5	14	4400	6500
2.4	0.37	84	37	1.3	17.73	IE1	BM09-../SSE06MA4	8.4	28	56	84	101	28	31	34	37	37	14	4400	6500
2.4	0.37	84	37	1.3	17.73	IE4	BM09-../S4E06LA4	8.4	28	56	84	101	37	37	37	37	37	14	4400	6500
2.4	0.37	70	44.5	1.3	21.2	IE4	BM09-../S4E06LA4	7	23.5	47	70	84	44.5	44.5	44.5	44.5	44.5	14	4400	6500
2.4	0.37	70	44.5	1.3	21.2	IE1	BM09-../SSE06MA4	7	23.5	47	70	84	33.5	37	41	44.5	44.5	14	4400	6500
2.4	0.37	60	52	1.1	24.74	IE4	BM09-../S4E06LA4	6	20	40	60	72	52	52	52	52	52	14	4400	6500
2.4	0.37	60	52	1.1	24.74	IE1	BM09-../SSE06MA4	6	20	40	60	72	39	43.5	47.5	52	52	14	4400	6500
2.4	0.37	57	54	1.3	25.98	IE4	BM09-../S4E06LA4	5.7	19	38	57	69	54	54	54	54	54	14	4400	6500
2.4	0.37	57	54	1.3	25.98	IE1	BM09-../SSE06MA4	5.7	19	38	57	69	41	45.5	50	54	54	14	4400	6500
2.4	0.37	49	64	1.1	30.31	IE4	BM09-../S4E06LA4	4.9	16	32.5	49	59	64	64	64	64	64	14	4400	6500
2.4	0.37	49	64	1.1	30.31	IE1	BM09-../SSE06MA4	4.9	16	32.5	49	59	48	53	58	64	64	14	4400	6500
2.4	0.37	45	69	1.2	32.97	IE4	BM09-../S4E06LA4	4.5	15	30	45	54	52	58	63	69	69	14	4400	6500
2.4	0.37	45	69	1.2	32.97	IE1	BM09-../SSE06MA4	4.5	15	30	45	54	69	69	69	69	69	14	4400	6500
2.4	0.37	39	81	1.1	38.46	IE1	BM09-../SSE06MA4	3.9	13	26	39	46.5	60	67	74	81	81	14	4400	6500
2.4	0.37	39	81	1.1	38.46	IE4	BM09-../S4E06LA4	3.9	13	26	39	46.5	81	81	81	81	81	14	4400	6500
2.4	0.37	35	88	0.96	42.44	IE1	BM09-../SSE06MA4	3.5	11.5	23.5	35	42	66	73	81	88	88	14	4400	6500
2.4	0.37	35	88	0.96	42.44	IE4	BM09-../S4E06LA4	3.5	11.5	23.5	35	42	88	88	88	88	88	14	4400	6500
2.4	0.37	27.5	112	0.96	53.85	IE4	BM09-../S4E06LA4	2.7	9.2	18.5	27.5	33	112	112	112	112	112	14	4400	6500
2.4	0.37	27.5	112	0.96	53.85	IE1	BM09-../SSE06MA4	2.7	9.2	18.5	27.5	33	84	93	103	112	112	14	4400	6500
2.4	0.37	59	52	3	25.09	IE4	BM10-../S4E06LA4	5.9	19.5	39.5	59	71	52	52	52	52	52	21	8000	10000
2.4	0.37	59	52	3	25.09	IE1	BM10-../SSE06MA4	5.9	19.5	39.5	59	71	39.5	44	48.5	52	52	21	8000	10000
2.4	0.37	56	56	2.7	26.55	IE4	BM10-../S4E06LA4	5.6	18.5	37.5	56	67	56	56	56	56	56	21	8000	10000
2.4	0.37	56	56	2.7	26.55	IE1	BM10-../SSE06MA4	5.6	18.5	37.5	56	67	42	46.5	51	56	56	21	8000	10000
2.4	0.37	50	62	2.6	29.45	IE1	BM10-../SSE06MA4	5	16.5	33.5	50	61	46.5	51	57	62	62	21	8000	10000
2.4	0.37	50	62	2.6	29.45	IE4	BM10-../S4E06LA4	5	16.5	33.5	50	61	62	62	62	62	62	21	8000	10000
2.4	0.37	45	68	2.2	33.19	IE1	BM10-../SSE06MA4	4.5	15	30	45	54	51	57	62	68	68	21	8000	10000
2.4	0.37	45	68	2.2	33.19	IE4	BM10-../S4E06LA4	4.5	15	30	45	54	68	68	68	68	68	21	8000	10000
2.4	0.37	40.5	75	2.1	36.82	IE4	BM10-../S4E06LA4	4	13.5	27	40.5	48.5	75	75	75	75	75	21	8000	10000
2.4	0.37	40.5	75	2.1	36.82	IE1	BM10-../SSE06MA4	4	13.5	27	40.5	48.5	56	63	69	75	75	21	8000	10000
2.4	0.37																			

# Geared motors for electric overhead conveyors series BM

Selection table asynchronous motors PMSM IE4 1500 1/<sub>min</sub>

MN = 2.4 Nm (PN = 0.37 kW)

IE4

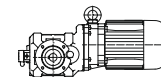

MN	PN	n <sub>2</sub>	M <sub>2</sub>	f <sub>B</sub>	i	IE-Classe	Type	Speed range n <sub>2</sub> [1/min]					Torque range M <sub>2</sub> [Nm]					m	FRN	FRV
								at engine speed n <sub>1</sub> [1/min]					at engine speed n <sub>1</sub> [1/min]							
								150	500	1000	1500	1800	150	500	1000	1500	1800			
2.4	0.37	25.5	114	1.4	58.18	IE4	BM10-../S4E06LA4	2.5	8.5	17	25.5	30.5	114	114	114	114	114	21	8000	10000
2.4	0.37	25.5	114	1.4	58.18	IE1	BM10-../SSE06MA4	2.5	8.5	17	25.5	30.5	85	95	104	114	114	21	8000	10000
2.4	0.37	33.5	96	1.5	44.15	IE4	BM10G06-../S4E06LA4	3.3	11	22.5	33.5	40.5	96	96	96	96	96	26	8000	10000
2.4	0.37	33.5	96	1.5	44.15	IE1	BM10G06-../SSE06MA4	3.3	11	22.5	33.5	40.5	72	80	88	96	96	26	8000	10000
2.4	0.37	28	115	1.2	53.03	IE1	BM10G06-../SSE06MA4	2.8	9.4	18.5	28	33.5	86	96	106	115	115	26	8000	10000
2.4	0.37	28	115	1.2	53.03	IE4	BM10G06-../S4E06LA4	2.8	9.4	18.5	28	33.5	115	115	115	115	115	26	8000	10000
2.4	0.37	25.5	128	1.2	58.79	IE4	BM10G06-../S4E06LA4	2.5	8.5	17	25.5	30.5	128	128	128	128	128	26	8000	10000
2.4	0.37	25.5	128	1.2	58.79	IE1	BM10G06-../SSE06MA4	2.5	8.5	17	25.5	30.5	96	106	117	128	128	26	8000	10000
2.4	0.37	21.5	152	0.92	69.61	IE4	BM10G06-../S4E06LA4	2.1	7.1	14	21.5	25.5	152	152	152	152	152	26	8000	10000
2.4	0.37	21.5	152	0.92	69.61	IE1	BM10G06-../SSE06MA4	2.1	7.1	14	21.5	25.5	114	126	139	152	152	26	8000	10000
2.4	0.37	20	158	0.91	74.41	IE4	BM10G06-../S4E06LA4	2	6.7	13	20	24	158	158	158	158	158	26	8000	10000
2.4	0.37	20	158	0.91	74.41	IE1	BM10G06-../SSE06MA4	2	6.7	13	20	24	119	132	145	158	158	26	8000	10000
2.4	0.37	18	176	0.88	82.54	IE1	BM10G06-../SSE06MA4	1.8	6	12	18	21.5	132	146	161	176	176	26	8000	10000
2.4	0.37	18	176	0.88	82.54	IE4	BM10G06-../S4E06LA4	1.8	6	12	18	21.5	176	176	176	176	176	26	8000	10000
2.4	0.37	42.5	80	2.7	35.25	IE1	BM20-../SSE06MA4	4.2	14	28	42.5	51	60	66	73	80	80	23	12000	12000
2.4	0.37	42.5	80	2.7	35.25	IE4	BM20-../S4E06LA4	4.2	14	28	42.5	51	80	80	80	80	80	23	12000	12000
2.4	0.37	35.5	96	2.3	42.18	IE1	BM20-../SSE06MA4	3.5	11.5	23.5	35.5	42.5	72	80	88	96	96	23	12000	12000
2.4	0.37	35.5	96	2.3	42.18	IE4	BM20-../S4E06LA4	3.5	11.5	23.5	35.5	42.5	96	96	96	96	96	23	12000	12000
2.4	0.37	28	120	1.7	52.84	IE1	BM20-../SSE06MA4	2.8	9.4	18.5	28	34	90	100	110	120	120	23	12000	12000
2.4	0.37	28	120	1.7	52.84	IE4	BM20-../S4E06LA4	2.8	9.4	18.5	28	34	120	120	120	120	120	23	12000	12000
2.4	0.37	24.5	138	1.4	60.64	IE1	BM20-../SSE06MA4	2.4	8.2	16	24.5	29.5	103	115	126	138	138	23	12000	12000
2.4	0.37	24.5	138	1.4	60.64	IE4	BM20-../S4E06LA4	2.4	8.2	16	24.5	29.5	138	138	138	138	138	23	12000	12000
2.4	0.37	20	170	1.1	74.76	IE4	BM20Z-../S4E06LA4	2	6.6	13	20	24	170	170	170	170	170	23	12000	12000
2.4	0.37	20	170	1.1	74.76	IE1	BM20Z-../SSE06MA4	2	6.6	13	20	24	127	142	156	170	170	23	12000	12000
2.4	0.37	43.5	78	2.1	34.35	IE1	BM20Z-../SSE06MA4	4.3	14.5	29	43.5	52	58	65	71	78	78	24	12000	12000
2.4	0.37	43.5	78	2.1	34.35	IE4	BM20Z-../S4E06LA4	4.3	14.5	29	43.5	52	78	78	78	78	78	24	12000	12000
2.4	0.37	33	102	2.1	45.15	IE4	BM20Z-../S4E06LA4	3.3	11	22	33	39.5	102	102	102	102	102	24	12000	12000
2.4	0.37	33	102	2.1	45.15	IE1	BM20Z-../SSE06MA4	3.3	11	22	33	39.5	77	85	94	102	102	24	12000	12000
2.4	0.37	22	152	1.4	66.74	IE4	BM20Z-../S4E06LA4	2.2	7.4	14.5	22	26.5	152	152	152	152	152	24	12000	12000
2.4	0.37	22	152	1.4	66.74	IE1	BM20Z-../SSE06MA4	2.2	7.4	14.5	22	26.5	114	126	139	152	152	24	12000	12000
2.4	0.37	17.5	194	1.1	85.45	IE4	BM20Z-../S4E06LA4	1.7	5.8	11.5	17.5	21	194	194	194	194	194	24	12000	12000
2.4	0.37	17.5	194	1.1	85.45	IE1	BM20Z-../SSE06MA4	1.7	5.8	11.5	17.5	21	146	162	178	194	194	24	12000	12000
2.4	0.37	15	225	0.97	99.47	IE4	BM20Z-../S4E06LA4	1.5	5	10	15	18	225	225	225	225	225	24	12000	12000
2.4	0.37	15	225	0.97	99.47	IE1	BM20Z-../SSE06MA4	1.5	5	10	15	18	170	188	205	225	225	24	12000	12000
2.4	0.37	12.5	265	0.82	117.9	IE1	BM20Z-../SSE06MA4	1.2	4.2	8.4	12.5	15	200	220	245	265	265	24	12000	12000
2.4	0.37	12.5	265	0.82	117.9	IE4	BM20Z-../S4E06LA4	1.2	4.2	8.4	12.5	15	265	265	265	265	265	24	12000	12000
2.4	0.37	30	106	3	49.66	IE4	BM30-../S4E06LA4	3	10	20	30	36	106	106	106	106	106	39	12000	15000
2.4	0.37	30	106	3	49.66	IE1	BM30-../SSE06MA4	3	10	20	30	36	79	88	97	106	106	39	12000	15000
2.4	0.37	24	129	2.1	61.33	IE4	BM30-../S4E06LA4	2.4	8.1	16	24	29	129	129	129	129	129	39	12000	15000
2.4	0.37	24	129	2.1	61.33	IE1	BM30-../SSE06MA4	2.4	8.1	16	24	29	97	107	118	129	129	39	12000	15000
2.4	0.37	21	150	1.7	71.09	IE4	BM30-../S4E06LA4	2.1	7	14	21	25	150	150	150	150	150	39	12000	15000
2.4	0.37	21	150	1.7	71.09	IE1	BM30-../SSE06MA4	2.1	7	14	21	25	112	125	137	150	150	39	12000	15000
2.4	0.37	27.5	112	2.5	53.67	IE4	BM30Z-../S4E06LA4	2.7	9.3	18.5	27.5	33.5	112	112	112	112	112	41	12000	15000
2.4	0.37	27.5	112	2.5	53.67	IE1	BM30Z-../SSE06MA4	2.7	9.3	18.5	27.5	33.5	84	93	102	112	112	41	12000	15000
2.4	0.37	21.5	144	2.4	69.35	IE1	BM30Z-../SSE06MA4	2.1	7.2	14	21.5	25.5	108	120	132	144	144	41	12000	15000
2.4	0.37	21.5	144	2.4	69.35	IE4	BM30Z-../S4E06LA4	2.1	7.2	14	21.5	25.5	144	144	144	144	144	41	12000	15000
2.4	0.37	17	179	2	85.96	IE4	BM30Z-../S4E06LA4	1.7	5.8	11.5	17	20.5	179	179	179	179	179	41	12000	15000
2.4	0.37	17	179	2	85.96	IE1	BM30Z-../SSE06MA4	1.7	5.8	11.5	17	20.5	134	149	164	179	179	41	12000	15000
2.4	0.37	14.5	205	1.7	100.7	IE4	BM30Z-../S4E06LA4	1.4	4.9	9.9	14.5	17.5	205	205	205	205	205	41	12000	15000
2.4	0.37	14.5	205	1.7	100.7	IE1	BM30Z-../SSE06MA4	1.4	4.9	9.9	14.5	17.5	155	173	190	205	205	41	12000	15000
2.4	0.37	11.5	260	1.3	128.2	IE4	BM30Z-../S4E06LA4	1.1	3.9	7.8	11.5	14	260	260	260	260	260	41	12000	15000
2.4	0.37	11.5	260	1.3	128.2	IE1	BM30Z-../SSE06MA4	1.1	3.9	7.8	11.5	14	198	220	240	260	260	41	12000	15000
2.4	0.37	9.9	305	1.1	150.3	IE1	BM30Z-../SSE06MA4	0.95	3.3	6.6	9.9	11.5	225	255	280	305	305	41	12000	15000
2.4	0.37	9.9	305	1.1	150.3	IE4	BM30Z-../S4E06LA4	0.95	3.3	6.6	9.9	11.5	305	305	305	305	305	41	12000	15000
2.4	0.37	8.4	360	0.97	177.2	IE1	BM30Z-../SSE06MA4	0.8	2.8	5.6	8.4	10	270	300	330	360	360	41	12000	15000
2.4	0.37	8.4	360	0.97	177.2	IE4	BM30Z-../S4E06LA4	0.8	2.8	5.6	8.4	10	360	360	360	360	360	41	12000	15000
2.4	0.37	8	400	0.87	186.7	IE1	BM30G06-../SSE06MA4	0.8	2.6	5.3	8	9.6	300	335	365	400	400	47	12000	15000
2.4	0.37	8	400	0.87	186.7	IE4	BM30G06-../S4E06LA4	0.8	2.6	5.3	8	9.6	400	400	400	400	400	47	12000	15000
2.4	0.37	12.5	240	2.8	118.2	IE1	BM40Z-../SSE06MA4	1.2	4.2	8.4	12.5	15	180	200	220	240	240	64	20000	25000
2.4	0.37	12.5	240	2.8	118.2	IE4	BM40Z-../S4E06LA4	1.2	4.2	8.4	12.5	15	240	240	240	240	240	64	20000	25000
2.4	0.37	10	285	2.4	143	IE4	BM40Z-../S4E06LA4	1	3.4	6.9	10	12.5	285	285	285	285	285	64	20000	25000
2.4	0.37	10	285	2.4	143	IE1	BM40Z-../SSE06MA4	1	3.4	6.9	10	12.5	215	240	260	285	285	64	20000	25000
2.4	0.37	8.8	335	2	169	IE4	BM40Z-../S4E06LA4	0.85	2.9	5.9	8.8	10.5	335	335	335	335	335	64	20000	25000
2.4	0.37	8.8	335																	

# Geared motors for electric overhead conveyors series BM

## Selection table asynchronous motors PMSM IE4 1500 <sup>1</sup>/<sub>min</sub>

**MN = 2.6 Nm (PN = 0.4 kW)**

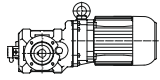

M <sub>N</sub>	P <sub>N</sub>	n <sub>2</sub>	M <sub>2</sub>	f <sub>B</sub>	i	IE- Classe	Type	Speed range n <sub>2</sub> [1/min]					Torque range M <sub>2</sub> [Nm]					m	F <sub>RN</sub>	F <sub>RV</sub>
								at engine speed n <sub>1</sub> [1/min]					at engine speed n <sub>1</sub> [1/min]							
								150	500	1000	1500	1800	150	500	1000	1500	1800			
2.6	0.4	132	25.5	1.2	11.34	IE4	BM09-../S4E06LA4	13	44	88	132	158	24.5	25.5	25.5	25.5	25.5	14	4400	6500
2.6	0.4	113	30	1.1	13.23	IE4	BM09-../S4E06LA4	11	37.5	75	113	136	29	30	30	30	30	14	4400	6500
2.6	0.4	84	40.5	1.2	17.73	IE4	BM09-../S4E06LA4	8.4	28	56	84	101	39	40.5	40.5	40.5	40.5	14	4400	6500
2.6	0.4	70	48.5	1.2	21.2	IE4	BM09-../S4E06LA4	7	23.5	47	70	84	46.5	48.5	48.5	48.5	48.5	14	4400	6500
2.6	0.4	60	56	1	24.74	IE4	BM09-../S4E06LA4	6	20	40	60	72	54	56	56	56	56	14	4400	6500
2.6	0.4	57	59	1.2	25.98	IE4	BM09-../S4E06LA4	5.7	19	38	57	69	57	59	59	59	59	14	4400	6500
2.6	0.4	49	69	1	30.31	IE4	BM09-../S4E06LA4	4.9	16	32.5	49	59	66	69	69	69	69	14	4400	6500
2.6	0.4	45	75	1.2	32.97	IE4	BM09-../S4E06LA4	4.5	15	30	45	54	72	75	75	75	75	14	4400	6500
2.6	0.4	39	87	1	38.46	IE4	BM09-../S4E06LA4	3.9	13	26	39	46.5	84	87	87	87	87	14	4400	6500
2.6	0.4	35	95	0.89	42.44	IE4	BM09-../S4E06LA4	3.5	11.5	23.5	35	42	92	95	95	95	95	14	4400	6500
2.6	0.4	27.5	121	0.89	53.85	IE4	BM09-../S4E06LA4	2.7	9.2	18.5	27.5	33	117	121	121	121	121	14	4400	6500
2.6	0.4	66	51	2.9	22.62	IE4	BM10-../S4E06LA4	6.6	22	44	66	79	49.5	51	51	51	51	21	8000	10000
2.6	0.4	59	57	2.8	25.09	IE4	BM10-../S4E06LA4	5.9	19.5	39.5	59	71	55	57	57	57	57	21	8000	10000
2.6	0.4	56	60	2.5	26.55	IE4	BM10-../S4E06LA4	5.6	18.5	37.5	56	67	58	60	60	60	60	21	8000	10000
2.6	0.4	50	67	2.4	29.45	IE4	BM10-../S4E06LA4	5	16.5	33.5	50	61	64	67	67	67	67	21	8000	10000
2.6	0.4	45	74	2	33.19	IE4	BM10-../S4E06LA4	4.5	15	30	45	54	71	74	74	74	74	21	8000	10000
2.6	0.4	40.5	82	1.9	36.82	IE4	BM10-../S4E06LA4	4	13.5	27	40.5	48.5	79	82	82	82	82	21	8000	10000
2.6	0.4	36.5	88	1.7	40.56	IE4	BM10-../S4E06LA4	3.6	12	24.5	36.5	44	85	88	88	88	88	21	8000	10000
2.6	0.4	33	98	1.6	45	IE4	BM10-../S4E06LA4	3.3	11	22	33	40	94	98	98	98	98	21	8000	10000
2.6	0.4	28.5	111	1.3	52.44	IE4	BM10-../S4E06LA4	2.8	9.5	19	28.5	34	107	111	111	111	111	21	8000	10000
2.6	0.4	25.5	124	1.3	58.18	IE4	BM10-../S4E06LA4	2.5	8.5	17	25.5	30.5	119	124	124	124	124	21	8000	10000
2.6	0.4	33.5	104	1.3	44.15	IE4	BM10G06-../S4E06LA4	3.3	11	22.5	33.5	40.5	100	104	104	104	104	26	8000	10000
2.6	0.4	28	125	1.1	53.03	IE4	BM10G06-../S4E06LA4	2.8	9.4	18.5	28	33.5	120	125	125	125	125	26	8000	10000
2.6	0.4	25.5	139	1.1	58.79	IE4	BM10G06-../S4E06LA4	2.5	8.5	17	25.5	30.5	133	139	139	139	139	26	8000	10000
2.6	0.4	21.5	164	0.85	69.61	IE4	BM10G06-../S4E06LA4	2.1	7.1	14	21.5	25.5	158	164	164	164	164	26	8000	10000
2.6	0.4	20	172	0.84	74.41	IE4	BM10G06-../S4E06LA4	2	6.7	13	20	24	165	172	172	172	172	26	8000	10000
2.6	0.4	18	190	0.81	82.54	IE4	BM10G06-../S4E06LA4	1.8	6	12	18	21.5	183	190	190	190	190	26	8000	10000
2.6	0.4	51	72	3	29.39	IE4	BM20-../S4E06LA4	5.1	17	34	51	61	69	72	72	72	72	23	12000	12000
2.6	0.4	42.5	87	2.5	35.25	IE4	BM20-../S4E06LA4	4.2	14	28	42.5	51	83	87	87	87	87	23	12000	12000
2.6	0.4	35.5	104	2.1	42.18	IE4	BM20-../S4E06LA4	3.5	11.5	23.5	35.5	42.5	100	104	104	104	104	23	12000	12000
2.6	0.4	28	130	1.6	52.84	IE4	BM20-../S4E06LA4	2.8	9.4	18.5	28	34	125	130	130	130	130	23	12000	12000
2.6	0.4	24.5	149	1.3	60.64	IE4	BM20-../S4E06LA4	2.4	8.2	16	24.5	29.5	144	149	149	149	149	23	12000	12000
2.6	0.4	20	184	0.99	74.76	IE4	BM20-../S4E06LA4	2	6.6	13	20	24	177	184	184	184	184	23	12000	12000
2.6	0.4	43.5	84	1.9	34.35	IE4	BM20Z-../S4E06LA4	4.3	14.5	29	43.5	52	81	84	84	84	84	24	12000	12000
2.6	0.4	33	111	1.9	45.15	IE4	BM20Z-../S4E06LA4	3.3	11	22	33	39.5	107	111	111	111	111	24	12000	12000
2.6	0.4	22	164	1.3	66.74	IE4	BM20Z-../S4E06LA4	2.2	7.4	14.5	22	26.5	158	164	164	164	164	24	12000	12000
2.6	0.4	17.5	210	1	85.45	IE4	BM20Z-../S4E06LA4	1.7	5.8	11.5	17.5	21	200	210	210	210	210	24	12000	12000
2.6	0.4	15	245	0.9	99.47	IE4	BM20Z-../S4E06LA4	1.5	5	10	15	18	235	245	245	245	245	24	12000	12000
2.6	0.4	30	114	2.7	49.66	IE4	BM30-../S4E06LA4	3	10	20	30	36	110	114	114	114	114	39	12000	15000
2.6	0.4	24	140	1.9	61.33	IE4	BM30-../S4E06LA4	2.4	8.1	16	24	29	134	140	140	140	140	39	12000	15000
2.6	0.4	21	162	1.6	71.09	IE4	BM30-../S4E06LA4	2.1	7	14	21	25	156	162	162	162	162	39	12000	15000
2.6	0.4	27.5	121	2.3	53.67	IE4	BM30Z-../S4E06LA4	2.7	9.3	18.5	27.5	33.5	116	121	121	121	121	41	12000	15000
2.6	0.4	21.5	156	2.2	69.35	IE4	BM30Z-../S4E06LA4	2.1	7.2	14	21.5	25.5	150	156	156	156	156	41	12000	15000
2.6	0.4	17	194	1.8	85.96	IE4	BM30Z-../S4E06LA4	1.7	5.8	11.5	17	20.5	186	194	194	194	194	41	12000	15000
2.6	0.4	14.5	225	1.6	100.7	IE4	BM30Z-../S4E06LA4	1.4	4.9	9.9	14.5	17.5	215	225	225	225	225	41	12000	15000
2.6	0.4	11.5	285	1.2	128.2	IE4	BM30Z-../S4E06LA4	1.1	3.9	7.8	11.5	14	275	285	285	285	285	41	12000	15000
2.6	0.4	9.9	330	1.1	150.3	IE4	BM30Z-../S4E06LA4	0.95	3.3	6.6	9.9	11.5	315	330	330	330	330	41	12000	15000
2.6	0.4	8.4	390	0.89	177.2	IE4	BM30Z-../S4E06LA4	0.8	2.8	5.6	8.4	10	375	390	390	390	390	41	12000	15000
2.6	0.4	8	435	0.8	186.7	IE4	BM30G06-../S4E06LA4	0.8	2.6	5.3	8	9.6	420	435	435	435	435	47	12000	15000
2.6	0.4	12.5	260	2.6	118.2	IE4	BM40Z-../S4E06LA4	1.2	4.2	8.4	12.5	15	250	260	260	260	260	64	20000	25000
2.6	0.4	10	310	2.2	143	IE4	BM40Z-../S4E06LA4	1	3.4	6.9	10	12.5	300	310	310	310	310	64	20000	25000
2.6	0.4	8.8	360	1.9	169	IE4	BM40Z-../S4E06LA4	0.85	2.9	5.9	8.8	10.5	350	360	360	360	360	64	20000	25000
2.6	0.4	7	450	1.5	211.5	IE4	BM40Z-../S4E06LA4	0.7	2.3	4.7	7	8.5	430	450	450	450	450	64	20000	25000
2.6	0.4	6	510	1.3	246.6	IE4	BM40Z-../S4E06LA4	0.6	2	4	6	7.2	495	510	510	510	510	64	20000	25000
2.6	0.4	5.1	610	0.97	289.8	IE4	BM40Z-../S4E06LA4	0.5	1.7	3.4	5.1	6.2	580	610	610	610	610	64	20000	25000

9

**MN = 3.5 Nm (PN = 0.55 kW)**

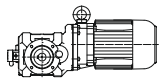

M <sub>N</sub>	P <sub>N</sub>	n <sub>2</sub>	M <sub>2</sub>	f <sub>B</sub>	i	IE- Classe	Type	Speed range n <sub>2</sub> [1/min]					Torque range M <sub>2</sub> [Nm]					m	F <sub>RN</sub>	F <sub>RV</sub>
								at engine speed n <sub>1</sub> [1/min]					at engine speed n <sub>1</sub> [1/min]							
								150	500	1000	1500	1800	150	500	1000	1500	1800			
3.5	0.55	132	34.5	0.86	11.34	IE1	BM09-../SSE06LA4	13	44	88	132	158	24.5	28.5	34.5	34.5	34.5	14	4400	6500
3.5	0.55	84	54	0.86	17.73	IE1	BM09-../SSE06LA4	8.4	28	56	84	101	39	45	54	54	54	14	4400	6500
3.5	0.55	70	65	0.86	21.2	IE1	BM09-../SSE06LA4	7	23.5	47	70	84	46.5	54	65	65	65	14	4400	6500
3.5	0.55	57	80	0.86	25.98	IE1	BM09-../SSE06LA4	5.7	19	38	57	69	57	66	80	80	80	14	4400	6500
3.5	0.55	45	101	0.86	32.97	IE1	BM09-../SSE06LA4	4.5	15	30	45	54	72	84	101	101	101	14	4400	6500
3.5	0.55	66	69	2.2	22.62	IE1	BM10-../SSE06LA4	6.6	22	44	66	79	49.5	57	69	69	69	21	8000	10000
3.5	0.55	59	77	2.1	25.09	IE1	BM10-../SSE06LA4	5.9	19.5	39.5	59	71	55	64	77	77	77	21	8000	10000
3.5	0.55																			

# Geared motors for electric overhead conveyors series BM

Selection table asynchronous motors PMSM IE4 1500 1/min

**MN = 3.5 Nm (PN = 0.55 kW)**

IE4

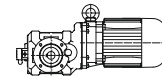

M <sub>N</sub>	P <sub>N</sub>	n <sub>2</sub>	M <sub>2</sub>	f <sub>B</sub>	i	IE- Classe	Type	Speed range n <sub>2</sub> [1/min]					Torque range M <sub>2</sub> [Nm]					m	F <sub>RN</sub>	F <sub>RV</sub>
								at engine speed n <sub>1</sub> [1/min]					at engine speed n <sub>1</sub> [1/min]							
								150	500	1000	1500	1800	150	500	1000	1500	1800			
3.5	0.55	36.5	119	1.3	40.56	IE1	BM10-../SSE06LA4	3.6	12	24.5	36.5	44	85	98	119	119	119	21	8000	10000
3.5	0.55	33	132	1.2	45	IE1	BM10-../SSE06LA4	3.3	11	22	33	40	94	109	132	132	132	21	8000	10000
3.5	0.55	28.5	150	1	52.44	IE1	BM10-../SSE06LA4	2.8	9.5	19	28.5	34	107	124	150	150	150	21	8000	10000
3.5	0.55	25.5	166	0.96	58.18	IE1	BM10-../SSE06LA4	2.5	8.5	17	25.5	30.5	119	138	166	166	166	21	8000	10000
3.5	0.55	33.5	140	1	44.15	IE1	BM10G06-../SSE06LA4	3.3	11	22.5	33.5	40.5	100	116	140	140	140	26	8000	10000
3.5	0.55	28	168	0.83	53.03	IE1	BM10G06-../SSE06LA4	2.8	9.4	18.5	28	33.5	120	139	168	168	168	26	8000	10000
3.5	0.55	25.5	187	0.8	58.79	IE1	BM10G06-../SSE06LA4	2.5	8.5	17	25.5	30.5	133	155	187	187	187	26	8000	10000
3.5	0.55	59	83	2.6	25.25	IE1	BM20-../SSE06LA4	5.9	19.5	39.5	59	71	59	69	83	83	83	23	12000	12000
3.5	0.55	51	97	2.3	29.39	IE1	BM20-../SSE06LA4	5.1	17	34	51	61	69	80	97	97	97	23	12000	12000
3.5	0.55	42.5	117	1.9	35.25	IE1	BM20-../SSE06LA4	4.2	14	28	42.5	51	83	97	117	117	117	23	12000	12000
3.5	0.55	35.5	140	1.6	42.18	IE1	BM20-../SSE06LA4	3.5	11.5	23.5	35.5	42.5	100	116	140	140	140	23	12000	12000
3.5	0.55	28	175	1.2	52.84	IE1	BM20-../SSE06LA4	2.8	9.4	18.5	28	34	125	145	175	175	175	23	12000	12000
3.5	0.55	24.5	200	0.96	60.64	IE1	BM20-../SSE06LA4	2.4	8.2	16	24.5	29.5	144	167	200	200	200	23	12000	12000
3.5	0.55	43.5	114	1.4	34.35	IE1	BM20Z-../SSE06LA4	4.3	14.5	29	43.5	52	81	94	114	114	114	24	12000	12000
3.5	0.55	33	150	1.4	45.15	IE1	BM20Z-../SSE06LA4	3.3	11	22	33	39.5	107	124	150	150	150	24	12000	12000
3.5	0.55	22	220	0.99	66.74	IE1	BM20Z-../SSE06LA4	2.2	7.4	14.5	22	26.5	158	183	220	220	220	24	12000	12000
3.5	0.55	36	129	2.7	41.13	IE1	BM30-../SSE06LA4	3.6	12	24	36	43.5	92	107	129	129	129	39	12000	15000
3.5	0.55	30	154	2	49.66	IE1	BM30-../SSE06LA4	3	10	20	30	36	110	128	154	154	154	39	12000	15000
3.5	0.55	24	188	1.4	61.33	IE1	BM30-../SSE06LA4	2.4	8.1	16	24	29	134	156	188	188	188	39	12000	15000
3.5	0.55	21	215	1.2	71.09	IE1	BM30-../SSE06LA4	2.1	7	14	21	25	156	181	215	215	215	39	12000	15000
3.5	0.55	27.5	163	1.7	53.67	IE1	BM30Z-../SSE06LA4	2.7	9.3	18.5	27.5	33.5	116	135	163	163	163	41	12000	15000
3.5	0.55	21.5	210	1.7	69.35	IE1	BM30Z-../SSE06LA4	2.1	7.2	14	21.5	25.5	150	174	210	210	210	41	12000	15000
3.5	0.55	17	260	1.3	85.96	IE1	BM30Z-../SSE06LA4	1.7	5.8	11.5	17	20.5	186	215	260	260	260	41	12000	15000
3.5	0.55	14.5	300	1.2	100.7	IE1	BM30Z-../SSE06LA4	1.4	4.9	9.9	14.5	17.5	215	250	300	300	300	41	12000	15000
3.5	0.55	11.5	385	0.91	128.2	IE1	BM30Z-../SSE06LA4	1.1	3.9	7.8	11.5	14	275	315	385	385	385	41	12000	15000
3.5	0.55	12.5	350	1.9	118.2	IE1	BM40Z-../SSE06LA4	1.2	4.2	8.4	12.5	15	250	290	350	350	350	64	20000	25000
3.5	0.55	10	420	1.6	143	IE1	BM40Z-../SSE06LA4	1	3.4	6.9	10	12.5	300	345	420	420	420	64	20000	25000
3.5	0.55	8.8	490	1.4	169	IE1	BM40Z-../SSE06LA4	0.85	2.9	5.9	8.8	10.5	350	405	490	490	490	64	20000	25000
3.5	0.55	7	600	1.1	211.5	IE1	BM40Z-../SSE06LA4	0.7	2.3	4.7	7	8.5	430	500	600	600	600	64	20000	25000
3.5	0.55	6	690	0.97	246.6	IE1	BM40Z-../SSE06LA4	0.6	2	4	6	7.2	495	570	690	690	690	64	20000	25000

9

**MN = 5 Nm (PN = 0.78 kW)**

IE4

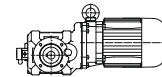

M <sub>N</sub>	P <sub>N</sub>	n <sub>2</sub>	M <sub>2</sub>	f <sub>B</sub>	i	IE- Classe	Type	Speed range n <sub>2</sub> [1/min]					Torque range M <sub>2</sub> [Nm]					m	F <sub>RN</sub>	F <sub>RV</sub>
								at engine speed n <sub>1</sub> [1/min]					at engine speed n <sub>1</sub> [1/min]							
								150	500	1000	1500	1800	150	500	1000	1500	1800			
5	0.78	128	53	2.6	11.68	IE4	BM10-../S4E08MA4	12.5	42.5	85	128	154	53	53	53	53	24	8000	10000	
5	0.78	115	58	2.5	12.95	IE4	BM10-../S4E08MA4	11.5	38.5	77	115	138	58	58	58	58	24	8000	10000	
5	0.78	91	72	2	16.39	IE4	BM10-../S4E08MA4	9.1	30.5	61	91	109	72	72	72	72	24	8000	10000	
5	0.78	82	80	1.9	18.18	IE4	BM10-../S4E08MA4	8.2	27.5	55	82	99	80	80	80	80	24	8000	10000	
5	0.78	66	99	1.5	22.62	IE4	BM10-../S4E08MA4	6.6	22	44	66	79	99	99	99	99	24	8000	10000	
5	0.78	59	110	1.4	25.09	IE4	BM10-../S4E08MA4	5.9	19.5	39.5	59	71	110	110	110	110	24	8000	10000	
5	0.78	56	116	1.3	26.55	IE4	BM10-../S4E08MA4	5.6	18.5	37.5	56	67	116	116	116	116	24	8000	10000	
5	0.78	50	129	1.2	29.45	IE4	BM10-../S4E08MA4	5	16.5	33.5	50	61	129	129	129	129	24	8000	10000	
5	0.78	45	142	1.1	33.19	IE4	BM10-../S4E08MA4	4.5	15	30	45	54	142	142	142	142	24	8000	10000	
5	0.78	40.5	158	1	36.82	IE4	BM10-../S4E08MA4	4	13.5	27	40.5	48.5	158	158	158	158	24	8000	10000	
5	0.78	36.5	170	0.88	40.56	IE4	BM10-../S4E08MA4	3.6	12	24.5	36.5	44	170	170	170	170	24	8000	10000	
5	0.78	33	189	0.85	45	IE4	BM10-../S4E08MA4	3.3	11	22	33	40	189	189	189	189	24	8000	10000	
5	0.78	89	79	2.8	16.72	IE4	BM20-../S4E08MA4	8.9	29.5	59	89	107	79	79	79	79	26	12000	12000	
5	0.78	76	93	2.3	19.72	IE4	BM20-../S4E08MA4	7.6	25	50	76	91	93	93	93	93	26	12000	12000	
5	0.78	59	119	1.8	25.25	IE4	BM20-../S4E08MA4	5.9	19.5	39.5	59	71	119	119	119	119	26	12000	12000	
5	0.78	51	139	1.6	29.39	IE4	BM20-../S4E08MA4	5.1	17	34	51	61	139	139	139	139	26	12000	12000	
5	0.78	42.5	167	1.3	35.25	IE4	BM20-../S4E08MA4	4.2	14	28	42.5	51	167	167	167	167	26	12000	12000	
5	0.78	35.5	200	1.1	42.18	IE4	BM20-../S4E08MA4	3.5	11.5	23.5	35.5	42.5	200	200	200	200	26	12000	12000	
5	0.78	28	250	0.83	52.84	IE4	BM20-../S4E08MA4	2.8	9.4	18.5	28	34	250	250	250	250	26	12000	12000	
5	0.78	43.5	163	1	34.35	IE4	BM20Z-../S4E08MA4	4.3	14.5	29	43.5	52	163	163	163	163	28	12000	12000	
5	0.78	33	210	1	45.15	IE4	BM20Z-../S4E08MA4	3.3	11	22	33	39.5	210	210	210	210	28	12000	12000	
5	0.78	50	135	2.6	29.76	IE4	BM30-../S4E08MA4	5	16.5	33.5	50	60	135	135	135	135	42	12000	15000	
5	0.78	43	158	2.2	34.88	IE4	BM30-../S4E08MA4	4.3	14	28.5	43	51	158	158	158	158	42	12000	15000	
5	0.78	36	185	1.9	41.13	IE4	BM30-../S4E08MA4	3.6	12	24	36	43.5	185	185	185	185	42	12000	15000	
5	0.78	30	220	1.4	49.66	IE4	BM30-../S4E08MA4	3	10	20	30	36	220	220	220	220	42	12000	15000	
5	0.78	24	265	1	61.33	IE4	BM30-../S4E08MA4	2.4	8.1	16	24	29	265	265	265	265	42	12000	15000	
5	0.78	21	310	0.82	71.09	IE4	BM30-../S4E08MA4	2.1	7	14	21	25	310	310	310	310	42	12000	15000	
5	0.78	27.5	230	1.2	53.67	IE4	BM30Z-../S4E08MA4	2.7	9.3	18.5	27.5	33.5	230	230	230	230	45	12000	15000	
5	0.78	21.5	300	1.2	69.35	IE4	BM30Z-../S4E08MA4	2.1	7.2	14	21.5	25.5	300	300	300	300	45	12000	15000	
5	0.78	17	370	0.94	85.96	IE4	BM30Z-../S4E08MA4	1.7	5.8	11.5	17	20.5	370	370	370	370	45	12000	15000	
5	0.78	14.5	430	0.81	100.7	IE4	BM30Z-../S4E08MA4	1.4	4.9											



# Geared motors for electric overhead conveyors series BM

## Selection table asynchronous motors PMSM IE4 1500 1/min

### MN = 5 Nm (PN = 0.78 kW)

IE4

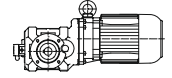

M <sub>N</sub> [Nm]	P <sub>N</sub> [kW]	n <sub>2</sub> [1/min]	M <sub>2</sub> [Nm]	f <sub>B</sub> [-]	i [:1]	IE- Classe	Type	Speed range n <sub>2</sub> [1/min]					Torque range M <sub>2</sub> [Nm]					m [kg]	F <sub>RN</sub> [N]	F <sub>RV</sub> [N]
								at engine speed n <sub>1</sub> [1/min]					at engine speed n <sub>1</sub> [1/min]							
								150	500	1000	1500	1800	150	500	1000	1500	1800			
5	0.78	14	440	1.4	104	IE4	BM40-../S4E08MA4	1.4	4.8	9.6	14	17	440	440	440	440	440	63	20000	25000
5	0.78	12.5	500	1.4	118.2	IE4	BM40Z-../S4E08MA4	1.2	4.2	8.4	12.5	15	500	500	500	500	500	67	20000	25000
5	0.78	10	600	1.1	143	IE4	BM40Z-../S4E08MA4	1	3.4	6.9	10	12.5	600	600	600	600	600	67	20000	25000
5	0.78	8.8	700	0.97	169	IE4	BM40Z-../S4E08MA4	0.85	2.9	5.9	8.8	10.5	700	700	700	700	700	67	20000	25000

### MN = 7 Nm (PN = 1.1 kW)

IE4

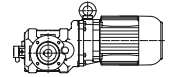

M <sub>N</sub> [Nm]	P <sub>N</sub> [kW]	n <sub>2</sub> [1/min]	M <sub>2</sub> [Nm]	f <sub>B</sub> [-]	i [:1]	IE- Classe	Type	Speed range n <sub>2</sub> [1/min]					Torque range M <sub>2</sub> [Nm]					m [kg]	F <sub>RN</sub> [N]	F <sub>RV</sub> [N]
								at engine speed n <sub>1</sub> [1/min]					at engine speed n <sub>1</sub> [1/min]							
								150	500	1000	1500	1800	150	500	1000	1500	1800			
7	1.1	128	74	1.9	11.68	IE3	BM10-../SPE08LA4	12.5	42.5	85	128	154	69	74	74	74	74	26	8000	10000
7	1.1	115	82	1.8	12.95	IE3	BM10-../SPE08LA4	11.5	38.5	77	115	138	76	82	82	82	82	26	8000	10000
7	1.1	91	102	1.4	16.39	IE3	BM10-../SPE08LA4	9.1	30.5	61	91	109	94	102	102	102	102	26	8000	10000
7	1.1	82	113	1.4	18.18	IE3	BM10-../SPE08LA4	8.2	27.5	55	82	99	105	113	113	113	113	26	8000	10000
7	1.1	66	139	1.1	22.62	IE3	BM10-../SPE08LA4	6.6	22	44	66	79	129	139	139	139	139	26	8000	10000
7	1.1	59	154	1	25.09	IE3	BM10-../SPE08LA4	5.9	19.5	39.5	59	71	143	154	154	154	154	26	8000	10000
7	1.1	56	163	0.92	26.55	IE3	BM10-../SPE08LA4	5.6	18.5	37.5	56	67	151	163	163	163	163	26	8000	10000
7	1.1	50	181	0.88	29.45	IE3	BM10-../SPE08LA4	5	16.5	33.5	50	61	168	181	181	181	181	26	8000	10000
7	1.1	112	88	2.5	13.34	IE3	BM20-../SPE08LA4	11	37	74	112	134	82	88	88	88	88	28	12000	12000
7	1.1	89	111	2	16.72	IE3	BM20-../SPE08LA4	8.9	29.5	59	89	107	103	111	111	111	111	28	12000	12000
7	1.1	76	131	1.7	19.72	IE3	BM20-../SPE08LA4	7.6	25	50	76	91	121	131	131	131	131	28	12000	12000
7	1.1	59	167	1.3	25.25	IE3	BM20-../SPE08LA4	5.9	19.5	39.5	59	71	155	167	167	167	167	28	12000	12000
7	1.1	51	195	1.1	29.39	IE3	BM20-../SPE08LA4	5.1	17	34	51	61	181	195	195	195	195	28	12000	12000
7	1.1	42.5	230	0.94	35.25	IE3	BM20-../SPE08LA4	4.2	14	28	42.5	51	215	230	230	230	230	28	12000	12000
7	1.1	75	128	2.7	19.96	IE3	BM30-../SPE08LA4	7.5	25	50	75	90	119	128	128	128	128	44	12000	15000
7	1.1	64	148	2.4	23.38	IE3	BM30-../SPE08LA4	6.4	21	42.5	64	76	138	148	148	148	148	44	12000	15000
7	1.1	50	189	1.8	29.76	IE3	BM30-../SPE08LA4	5	16.5	33.5	50	60	176	189	189	189	189	44	12000	15000
7	1.1	43	220	1.6	34.88	IE3	BM30-../SPE08LA4	4.3	14	28.5	43	51	205	220	220	220	220	44	12000	15000
7	1.1	36	255	1.4	41.13	IE3	BM30-../SPE08LA4	3.6	12	24	36	43.5	240	255	255	255	255	44	12000	15000
7	1.1	30	305	1	49.66	IE3	BM30-../SPE08LA4	3	10	20	30	36	285	305	305	305	305	44	12000	15000
7	1.1	27.5	325	0.86	53.67	IE3	BM30Z-../SPE08LA4	2.7	9.3	18.5	27.5	33.5	300	325	325	325	325	46	12000	15000
7	1.1	21.5	420	0.83	69.35	IE3	BM30Z-../SPE08LA4	2.1	7.2	14	21.5	25.5	390	420	420	420	420	46	12000	15000
7	1.1	36.5	255	2.6	40.88	IE3	BM40-../SPE08LA4	3.6	12	24	36.5	44	235	255	255	255	255	64	20000	25000
7	1.1	29	315	2.2	51.18	IE3	BM40-../SPE08LA4	2.9	9.7	19.5	29	35	290	315	315	315	315	64	20000	25000
7	1.1	25	365	1.9	59.66	IE3	BM40-../SPE08LA4	2.5	8.3	16.5	25	30	340	365	365	365	365	64	20000	25000
7	1.1	21	425	1.6	70.11	IE3	BM40-../SPE08LA4	2.1	7.1	14	21	25.5	395	425	425	425	425	64	20000	25000
7	1.1	17.5	510	1.2	84.36	IE3	BM40-../SPE08LA4	1.7	5.9	11.5	17.5	21	475	510	510	510	510	64	20000	25000
7	1.1	14	610	0.97	104	IE3	BM40-../SPE08LA4	1.4	4.8	9.6	14	17	570	610	610	610	610	64	20000	25000
7	1.1	12.5	700	0.97	118.2	IE3	BM40Z-../SPE08LA4	1.2	4.2	8.4	12.5	15	650	700	700	700	700	69	20000	25000
7	1.1	10	840	0.81	143	IE3	BM40Z-../SPE08LA4	1	3.4	6.9	10	12.5	780	840	840	840	840	69	20000	25000

### MN = 10 Nm (PN = 1.55 kW)

IE4

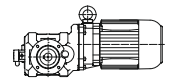

M <sub>N</sub> [Nm]	P <sub>N</sub> [kW]	n <sub>2</sub> [1/min]	M <sub>2</sub> [Nm]	f <sub>B</sub> [-]	i [:1]	IE- Classe	Type	Speed range n <sub>2</sub> [1/min]					Torque range M <sub>2</sub> [Nm]					m [kg]	F <sub>RN</sub> [N]	F <sub>RV</sub> [N]	
								at engine speed n <sub>1</sub> [1/min]					at engine speed n <sub>1</sub> [1/min]								
								150	500	1000	1500	1800	150	500	1000	1500	1800				
10	1.55	128	106	1.3	11.68	IE1	BM10-../SSE08LA4	12.5	42.5	85	128	154	69	85	106	106	106	106	26	8000	10000
10	1.55	128	106	1.3	11.68	IE4	BM10-../S4E09SA4	12.5	42.5	85	128	154	90	106	106	106	106	106	30	8000	10000
10	1.55	115	117	1.3	12.95	IE4	BM10-../S4E09SA4	11.5	38.5	77	115	138	100	117	117	117	117	117	30	8000	10000
10	1.55	91	117	1.3	12.95	IE1	BM10-../SSE08LA4	11.5	38.5	77	115	138	76	94	117	117	117	117	26	8000	10000
10	1.55	91	145	0.99	16.39	IE4	BM10-../S4E09SA4	9.1	30.5	61	91	109	123	145	145	145	145	145	30	8000	10000
10	1.55	91	145	0.99	16.39	IE1	BM10-../SSE08LA4	9.1	30.5	61	91	109	94	116	145	145	145	145	26	8000	10000
10	1.55	82	161	0.96	18.18	IE1	BM10-../SSE08LA4	8.2	27.5	55	82	99	105	129	161	161	161	161	26	8000	10000
10	1.55	82	161	0.96	18.18	IE4	BM10-../S4E09SA4	8.2	27.5	55	82	99	137	161	161	161	161	161	30	8000	10000
10	1.55	195	72	2.7	7.66	IE4	BM20-../S4E09SA4	19.5	65	130	195	230	61	72	72	72	72	32	9100	10900	
10	1.55	195	72	2.7	7.66	IE1	BM20-../SSE08LA4	19.5	65	130	195	230	47	58	72	72	72	28	9100	10900	
10	1.55	147	96	2.3	10.15	IE1	BM20-../SSE08LA4	14.5	49	98	147	177	62	77	96	96	96	28	12000	12000	
10	1.55	147	96	2.3	10.15	IE4	BM20-../S4E09SA4	14.5	49	98	147	177	81	96	96	96	96	32	12000	12000	
10	1.55	112	126	1.7	13.34	IE1	BM20-../SSE08LA4	11	37	74	112	134	82	101	126	126	126	28	12000	12000	
10	1.55	112	126	1.7	13.34	IE4	BM20-../S4E09SA4	11	37	74	112	134	107	126	126	126	126	32	12000	12000	
10	1.55	89	158	1.4	16.72	IE4	BM20-../S4E09SA4	8.9	29.5	59	89	107	135	158	158	158	158	32	12000	12000	
10	1.55	89	158	1.4	16.72	IE1	BM20-../SSE08LA4	8.9	29.5	59	89	107	103	127	158	158	158	28	12000	12000	
10	1.55	76	187	1.2	19.72	IE1	BM20-../SSE08LA4	7.6	25	50	76	91	121	149	187	187	187	28	12000	12000	
10	1.55	76	187</																		

# Geared motors for electric overhead conveyors series BM

## Selection table asynchronous motors PMSM IE4 1500 1/min

### MN = 10 Nm (PN = 1.55 kW)

IE4

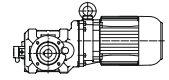

M <sub>N</sub> [Nm]	P <sub>N</sub> [kW]	n <sub>2</sub> [1/min]	M <sub>2</sub> [Nm]	f <sub>B</sub> [--]	i [:1]	IE- Classe	Type	Speed range n <sub>2</sub> [1/min]					Torque range M <sub>2</sub> [Nm]					m [kg]	F <sub>RN</sub> [N]	F <sub>RV</sub> [N]
								at engine speed n <sub>1</sub> [1/min]					at engine speed n <sub>1</sub> [1/min]							
								150	500	1000	1500	1800	150	500	1000	1500	1800			
10	1.55	93	148	2.4	16.1	IE4	BM30-../S4E09SA4	9.3	31	62	93	111	125	148	148	148	148	48	12000	15000
10	1.55	75	183	1.9	19.96	IE4	BM30-../S4E09SA4	7.5	25	50	75	90	156	183	183	183	183	48	12000	15000
10	1.55	75	183	1.9	19.96	IE1	BM30-../SSE08LA4	7.5	25	50	75	90	119	146	183	183	183	44	12000	15000
10	1.55	64	210	1.6	23.38	IE4	BM30-../S4E09SA4	6.4	21	42.5	64	76	180	210	210	210	210	48	12000	15000
10	1.55	64	210	1.6	23.38	IE1	BM30-../SSE08LA4	6.4	21	42.5	64	76	138	170	210	210	210	44	12000	15000
10	1.55	50	270	1.3	29.76	IE4	BM30-../S4E09SA4	5	16.5	33.5	50	60	176	215	270	270	270	44	12000	15000
10	1.55	50	270	1.3	29.76	IE1	BM30-../S4E09SA4	5	16.5	33.5	50	60	230	270	270	270	270	48	12000	15000
10	1.55	43	315	1.1	34.88	IE4	BM30-../S4E09SA4	4.3	14	28.5	43	51	265	315	315	315	315	48	12000	15000
10	1.55	43	315	1.1	34.88	IE1	BM30-../SSE08LA4	4.3	14	28.5	43	51	205	250	315	315	315	44	12000	15000
10	1.55	36	370	0.95	41.13	IE1	BM30-../SSE08LA4	3.6	12	24	36	43.5	240	295	370	370	370	44	12000	15000
10	1.55	36	370	0.95	41.13	IE4	BM30-../S4E09SA4	3.6	12	24	36	43.5	310	370	370	370	370	48	12000	15000
10	1.55	52	255	2.6	28.59	IE4	BM40-../S4E09SA4	5.2	17	34.5	52	62	215	255	255	255	255	68	20000	25000
10	1.55	52	255	2.6	28.59	IE1	BM40-../SSE08LA4	5.2	17	34.5	52	62	167	205	255	255	255	64	20000	25000
10	1.55	43	310	2.2	34.61	IE4	BM40-../S4E09SA4	4.3	14	28.5	43	52	260	310	310	310	310	68	20000	25000
10	1.55	43	310	2.2	34.61	IE1	BM40-../SSE08LA4	4.3	14	28.5	43	52	200	245	310	310	310	64	20000	25000
10	1.55	36.5	365	1.8	40.88	IE4	BM40-../S4E09SA4	3.6	12	24	36.5	44	310	365	365	365	365	68	20000	25000
10	1.55	36.5	365	1.8	40.88	IE1	BM40-../SSE08LA4	3.6	12	24	36.5	44	235	290	365	365	365	64	20000	25000
10	1.55	29	450	1.5	51.18	IE4	BM40-../S4E09SA4	2.9	9.7	19.5	29	35	380	450	450	450	450	68	20000	25000
10	1.55	29	450	1.5	51.18	IE1	BM40-../SSE08LA4	2.9	9.7	19.5	29	35	290	360	450	450	450	64	20000	25000
10	1.55	25	520	1.3	59.66	IE4	BM40-../S4E09SA4	2.5	8.3	16.5	25	30	445	520	520	520	520	68	20000	25000
10	1.55	25	520	1.3	59.66	IE1	BM40-../SSE08LA4	2.5	8.3	16.5	25	30	340	420	520	520	520	64	20000	25000
10	1.55	21	600	1.1	70.11	IE4	BM40-../S4E09SA4	2.1	7.1	14	21	25.5	510	600	600	600	600	68	20000	25000
10	1.55	21	600	1.1	70.11	IE1	BM40-../SSE08LA4	2.1	7.1	14	21	25.5	395	485	600	600	600	64	20000	25000
10	1.55	17.5	730	0.82	84.36	IE1	BM40-../SSE08LA4	1.7	5.9	11.5	17.5	21	475	580	730	730	730	64	20000	25000
10	1.55	17.5	730	0.82	84.36	IE4	BM40-../S4E09SA4	1.7	5.9	11.5	17.5	21	620	730	730	730	730	68	20000	25000

### MN = 14 Nm (PN = 2.2 kW)

IE4

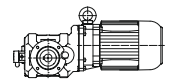

M <sub>N</sub> [Nm]	P <sub>N</sub> [kW]	n <sub>2</sub> [1/min]	M <sub>2</sub> [Nm]	f <sub>B</sub> [--]	i [:1]	IE- Classe	Type	Speed range n <sub>2</sub> [1/min]					Torque range M <sub>2</sub> [Nm]					m [kg]	F <sub>RN</sub> [N]	F <sub>RV</sub> [N]
								at engine speed n <sub>1</sub> [1/min]					at engine speed n <sub>1</sub> [1/min]							
								150	500	1000	1500	1800	150	500	1000	1500	1800			
14	2.2	128	148	0.94	11.68	IE5	BM10-../S5E09XA4	12.5	42.5	85	128	154	138	148	148	148	148	38	8000	10000
14	2.2	128	148	0.94	11.68	IE2	BM10-../SHE09SA4	12.5	42.5	85	128	154	90	106	148	148	148	30	8000	10000
14	2.2	115	164	0.91	12.95	IE2	BM10-../SHE09SA4	11.5	38.5	77	115	138	100	117	164	164	164	30	8000	10000
14	2.2	115	164	0.91	12.95	IE5	BM10-../S5E09XA4	11.5	38.5	77	115	138	153	164	164	164	164	38	8000	10000
14	2.2	195	101	2	7.66	IE5	BM20-../S5E09XA4	19.5	65	130	195	230	94	101	101	101	101	40	9100	10900
14	2.2	195	101	2	7.66	IE2	BM20-../SHE09SA4	19.5	65	130	195	230	61	72	101	101	101	32	9100	10900
14	2.2	147	134	1.6	10.15	IE5	BM20-../S5E09XA4	14.5	49	98	147	177	125	134	134	134	134	40	12000	12000
14	2.2	147	134	1.6	10.15	IE2	BM20-../SHE09SA4	14.5	49	98	147	177	81	96	134	134	134	32	12000	12000
14	2.2	112	177	1.2	13.34	IE5	BM20-../S5E09XA4	11	37	74	112	134	164	177	177	177	177	40	12000	12000
14	2.2	112	177	1.2	13.34	IE2	BM20-../SHE09SA4	11	37	74	112	134	107	126	177	177	177	32	12000	12000
14	2.2	89	220	0.99	16.72	IE5	BM20-../S5E09XA4	8.9	29.5	59	89	107	205	220	220	220	220	40	12000	12000
14	2.2	89	220	0.99	16.72	IE2	BM20-../SHE09SA4	8.9	29.5	59	89	107	135	158	220	220	220	32	12000	12000
14	2.2	76	260	0.84	19.72	IE5	BM20-../S5E09XA4	7.6	25	50	76	91	240	260	260	260	260	40	12000	12000
14	2.2	76	260	0.84	19.72	IE2	BM20-../SHE09SA4	7.6	25	50	76	91	159	187	260	260	260	32	12000	12000
14	2.2	149	129	2.7	10.06	IE5	BM30-../S5E09XA4	14.5	49.5	99	149	178	120	129	129	129	129	56	12000	15000
14	2.2	149	129	2.7	10.06	IE2	BM30-../SHE09SA4	14.5	49.5	99	149	178	78	92	129	129	129	48	12000	15000
14	2.2	120	160	2.2	12.46	IE5	BM30-../S5E09XA4	12	40	80	120	144	149	160	160	160	160	56	12000	15000
14	2.2	120	160	2.2	12.46	IE2	BM30-../SHE09SA4	12	40	80	120	144	97	114	160	160	160	48	12000	15000
14	2.2	93	205	1.7	16.1	IE2	BM30-../SHE09SA4	9.3	31	62	93	111	125	148	205	205	205	48	12000	15000
14	2.2	93	205	1.7	16.1	IE5	BM30-../S5E09XA4	9.3	31	62	93	111	192	205	205	205	205	56	12000	15000
14	2.2	75	255	1.4	19.96	IE5	BM30-../S5E09XA4	7.5	25	50	75	90	235	255	255	255	255	56	12000	15000
14	2.2	75	255	1.4	19.96	IE2	BM30-../SHE09SA4	7.5	25	50	75	90	156	183	255	255	255	48	12000	15000
14	2.2	64	295	1.2	23.38	IE5	BM30-../S5E09XA4	6.4	21	42.5	64	76	275	295	295	295	295	56	12000	15000
14	2.2	64	295	1.2	23.38	IE2	BM30-../SHE09SA4	6.4	21	42.5	64	76	180	210	295	295	295	48	12000	15000
14	2.2	50	375	0.92	29.76	IE2	BM30-../SHE09SA4	5	16.5	33.5	50	60	230	270	375	375	375	48	12000	15000
14	2.2	50	375	0.92	29.76	IE5	BM30-../S5E09XA4	5	16.5	33.5	50	60	350	375	375	375	375	56	12000	15000
14	2.2	83	225	3	18.05	IE5	BM40-../S5E09XA4	8.3	27.5	55	83	99	210	225	225	225	225	76	20000	25000
14	2.2	83	225	3	18.05	IE2	BM40-../SHE09SA4	8.3	27.5	55	83	99	138	162	225	225	225	68	20000	25000
14	2.2	66	280	2.4	22.44	IE2	BM40-../SHE09SA4	6.6	22	44.5	66	80	171	200	280	280	280	68	20000	25000
14	2.2	66	280	2.4	22.44	IE5	BM40-../S5E09XA4	6.6	22	44.5	66	80	260	280	280	280	280	76	20000	25000
14	2.2	52	360	1.9	28.59	IE5	BM40-../S5E09XA4	5.2	17	34.5	52	62	330	360	360	360	360	76	20000	25000
14	2.2	52	360	1.9	28.59	IE2	BM40-../SHE09SA4	5.2	17	34.5	52	62	215	255	360	360	360	68	20000	25000
14	2.2	43	435	1.6	34.61	IE2	BM40-../SHE09SA4	4.3	14	28.5	43	52	260	310	435	435	435	68	20000	25000
14	2.2	43	435	1.6	34.61	IE5	BM40-../S5E09XA4	4.3	14	28.5	43	52	400	435	435	435	435	76	20000	25000
14	2.2	36.5	510	1.3	40.88	IE2	BM40-../SHE09SA4	3.6	12	24	36.5	44	310	365	510	510	510	68	20000	25000
14	2.2	36.5	510	1.3	40.88	IE5	BM40-../S5E09XA4	3.6	12	24	36.5	44	475	510	510	510	510	76	20000	25000
14	2.2	29	630	1.1	51.18	IE5	BM40-../S5E09XA4	2.9	9.7	19.5	29	35	580	630	630	630	630</			

# Geared motors for electric overhead conveyors series BM

## Selection table asynchronous motors PMSM IE4 1500 1/ min

### MN = 19 Nm (PN = 3 kW)

IE4

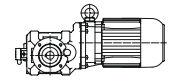

M <sub>N</sub> [Nm]	P <sub>N</sub> [kW]	n <sub>2</sub> [1/min]	M <sub>2</sub> [Nm]	f <sub>B</sub> [-]	i [:]	IE- Classe	Type	Speed range n <sub>2</sub> [1/min] at engine speed n <sub>1</sub> [1/min]					Torque range M <sub>2</sub> [Nm] at engine speed n <sub>1</sub> [1/min]					m [kg]	F <sub>RN</sub> [N]	F <sub>RV</sub> [N]
								150	500	1000	1500	1800	150	500	1000	1500	1800			
19	3	189	138	2.3	7.91	IE4	BM30-../S4E11SA6	18.5	63	126	189	225	138	138	138	138	138	65	11000	13800
19	3	149	175	2	10.06	IE4	BM30-../S4E11SA6	14.5	49.5	99	149	178	175	175	175	175	175	65	12000	15000
19	3	120	215	1.6	12.46	IE4	BM30-../S4E11SA6	12	40	80	120	144	215	215	215	215	215	65	12000	15000
19	3	93	280	1.2	16.1	IE4	BM30-../S4E11SA6	9.3	31	62	93	111	280	280	280	280	280	65	12000	15000
19	3	75	345	1	19.96	IE4	BM30-../S4E11SA6	7.5	25	50	75	90	345	345	345	345	345	65	12000	15000
19	3	64	400	0.87	23.38	IE4	BM30-../S4E11SA6	6.4	21	42.5	64	76	400	400	400	400	400	65	12000	15000
19	3	103	245	2.7	14.5	IE4	BM40-../S4E11SA6	10	34	68	103	124	245	245	245	245	245	90	20000	25000
19	3	83	305	2.2	18.05	IE4	BM40-../S4E11SA6	8.3	27.5	55	83	99	305	305	305	305	305	90	20000	25000
19	3	66	380	1.8	22.44	IE4	BM40-../S4E11SA6	6.6	22	44.5	66	80	380	380	380	380	380	90	20000	25000
19	3	52	485	1.4	28.59	IE4	BM40-../S4E11SA6	5.2	17	34.5	52	62	485	485	485	485	485	90	20000	25000
19	3	43	590	1.1	34.61	IE4	BM40-../S4E11SA6	4.3	14	28.5	43	52	590	590	590	590	590	90	20000	25000
19	3	36.5	690	0.97	40.88	IE4	BM40-../S4E11SA6	3.6	12	24	36.5	44	690	690	690	690	690	90	20000	25000

### MN = 20 Nm (PN = 3.1 kW)

IE4

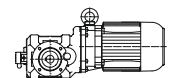

M <sub>N</sub> [Nm]	P <sub>N</sub> [kW]	n <sub>2</sub> [1/min]	M <sub>2</sub> [Nm]	f <sub>B</sub> [-]	i [:]	IE- Classe	Type	Speed range n <sub>2</sub> [1/min] at engine speed n <sub>1</sub> [1/min]					Torque range M <sub>2</sub> [Nm] at engine speed n <sub>1</sub> [1/min]					m [kg]	F <sub>RN</sub> [N]	F <sub>RV</sub> [N]
								150	500	1000	1500	1800	150	500	1000	1500	1800			
20	3.1	195	145	1.4	7.66	IE3	BM20-../SPE09XA4	19.5	65	130	195	230	94	116	145	145	145	40	9100	10900
20	3.1	147	192	1.1	10.15	IE3	BM20-../SPE09XA4	14.5	49	98	147	177	125	154	192	192	192	40	12000	12000
20	3.1	112	250	0.87	13.34	IE3	BM20-../SPE09XA4	11	37	74	112	134	164	200	250	250	250	40	12000	12000
20	3.1	189	145	2.2	7.91	IE3	BM30-../SPE09XA4	18.5	63	126	189	225	94	116	145	145	145	56	11000	13800
20	3.1	149	185	1.9	10.06	IE3	BM30-../SPE09XA4	14.5	49.5	99	149	178	120	148	185	185	185	56	12000	15000
20	3.1	120	225	1.5	12.46	IE3	BM30-../SPE09XA4	12	40	80	120	144	149	183	225	225	225	56	12000	15000
20	3.1	93	295	1.2	16.1	IE3	BM30-../SPE09XA4	9.3	31	62	93	111	192	235	295	295	295	56	12000	15000
20	3.1	75	365	0.95	19.96	IE3	BM30-../SPE09XA4	7.5	25	50	75	90	235	290	365	365	365	56	12000	15000
20	3.1	64	425	0.82	23.38	IE3	BM30-../SPE09XA4	6.4	21	42.5	64	76	275	340	425	425	425	56	12000	15000
20	3.1	103	260	2.6	14.5	IE3	BM40-../SPE09XA4	10	34	68	103	124	169	205	260	260	260	76	20000	25000
20	3.1	83	320	2.1	18.05	IE3	BM40-../SPE09XA4	8.3	27.5	55	83	99	210	255	320	320	320	76	20000	25000
20	3.1	66	400	1.7	22.44	IE3	BM40-../SPE09XA4	6.6	22	44.5	66	80	260	320	400	400	400	76	20000	25000
20	3.1	52	510	1.3	28.59	IE3	BM40-../SPE09XA4	5.2	17	34.5	52	62	330	410	510	510	510	76	20000	25000
20	3.1	43	620	1.1	34.61	IE3	BM40-../SPE09XA4	4.3	14	28.5	43	52	400	495	620	620	620	76	20000	25000
20	3.1	36.5	730	0.92	40.88	IE3	BM40-../SPE09XA4	3.6	12	24	36.5	44	475	580	730	730	730	76	20000	25000

### MN = 25.5 Nm (PN = 4 kW)

IE4

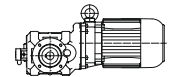

M <sub>N</sub> [Nm]	P <sub>N</sub> [kW]	n <sub>2</sub> [1/min]	M <sub>2</sub> [Nm]	f <sub>B</sub> [-]	i [:]	IE- Classe	Type	Speed range n <sub>2</sub> [1/min] at engine speed n <sub>1</sub> [1/min]					Torque range M <sub>2</sub> [Nm] at engine speed n <sub>1</sub> [1/min]					m [kg]	F <sub>RN</sub> [N]	F <sub>RV</sub> [N]
								150	500	1000	1500	1800	150	500	1000	1500	1800			
25.5	4	189	185	1.7	7.91	IE3	BM30-../SPE11SA6	18.5	63	126	189	225	138	160	185	185	185	65	11000	13800
25.5	4	149	235	1.5	10.06	IE3	BM30-../SPE11SA6	14.5	49.5	99	149	178	175	200	235	235	235	65	12000	15000
25.5	4	120	290	1.2	12.46	IE3	BM30-../SPE11SA6	12	40	80	120	144	215	250	290	290	290	65	12000	15000
25.5	4	93	375	0.93	16.1	IE3	BM30-../SPE11SA6	9.3	31	62	93	111	280	325	375	375	375	65	12000	15000
25.5	4	134	255	2.4	11.17	IE3	BM40-../SPE11SA6	13	44.5	89	134	161	191	220	255	255	255	90	18300	22900
25.5	4	103	330	2	14.5	IE3	BM40-../SPE11SA6	10	34	68	103	124	245	285	330	330	330	90	20000	25000
25.5	4	83	410	1.6	18.05	IE3	BM40-../SPE11SA6	8.3	27.5	55	83	99	305	355	410	410	410	90	20000	25000
25.5	4	66	510	1.3	22.44	IE3	BM40-../SPE11SA6	6.6	22	44.5	66	80	380	440	510	510	510	90	20000	25000
25.5	4	52	650	1	28.59	IE3	BM40-../SPE11SA6	5.2	17	34.5	52	62	485	560	650	650	650	90	20000	25000
25.5	4	43	790	0.86	34.61	IE3	BM40-../SPE11SA6	4.3	14	28.5	43	52	590	680	790	790	790	90	20000	25000

### MN = 26.5 Nm (PN = 4 kW)

IE4

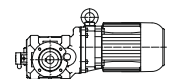

M <sub>N</sub> [Nm]	P <sub>N</sub> [kW]	n <sub>2</sub> [1/min]	M <sub>2</sub> [Nm]	f <sub>B</sub> [-]	i [:]	IE- Classe	Type	Speed range n <sub>2</sub> [1/min] at engine speed n <sub>1</sub> [1/min]					Torque range M <sub>2</sub> [Nm] at engine speed n <sub>1</sub> [1/min]					m [kg]	F <sub>RN</sub> [N]	F <sub>RV</sub> [N]
								150	500	1000	1500	1800	150	500	1000	1500	1800			
26.5	4	189	192	1.7	7.91	IE5	BM30-../S5E11MA6	18.5	63	126	189	225	192	192	192	192	192	65	11000	13800
26.5	4	149	245	1.4	10.06	IE5	BM30-../S5E11MA6	14.5	49.5	99	149	178	245	245	245	245	245	65	12000	15000
26.5	4	120	300	1.2	12.46	IE5	BM30-../S5E11MA6	12	40	80	120	144	300	300	300	300	300	65	12000	15000
26.5	4	93	390	0.89	16.1	IE5	BM30-../S5E11MA6	9.3	31	62	93	111	390	390	390	390	390	65	12000	15000
26.5	4	134	265	2.3	11.17	IE5	BM40-../S5E11MA6	13	44.5	89	134	161	265	265	265	265	265	90	18300	22900
26.5	4	103	345	2	14.5	IE5	BM40-../S5E11MA6	10	34	68	103	124	345	345	345	345	345	90	20000	25000

# Geared motors for electric overhead conveyors series BM

## Selection table asynchronous motors PMSM IE4 1500 1/ min

### MN = 26.5 Nm (PN = 4 kW)

IE4

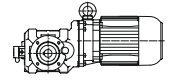

M <sub>N</sub> [Nm]	P <sub>N</sub> [kW]	n <sub>2</sub> [1/min]	M <sub>2</sub> [Nm]	f <sub>B</sub> [-]	i [:1]	IE- Classe	Type	Speed range n <sub>2</sub> [1/min]					Torque range M <sub>2</sub> [Nm]					m [kg]	F <sub>RN</sub> [N]	F <sub>RV</sub> [N]
								at engine speed n <sub>1</sub> [1/min]					at engine speed n <sub>1</sub> [1/min]							
								150	500	1000	1500	1800	150	500	1000	1500	1800			
26.5	4	83	430	1.6	18.05	IE5	BM40-../S5E11MA6	8.3	27.5	55	83	99	430	430	430	430	430	90	20000	25000
26.5	4	66	530	1.3	22.44	IE5	BM40-../S5E11MA6	6.6	22	44.5	66	80	530	530	530	530	530	90	20000	25000
26.5	4	52	680	1	28.59	IE5	BM40-../S5E11MA6	5.2	17	34.5	52	62	680	680	680	680	680	90	20000	25000
26.5	4	43	820	0.82	34.61	IE5	BM40-../S5E11MA6	4.3	14	28.5	43	52	820	820	820	820	820	90	20000	25000

### MN = 35 Nm (PN = 5.5 kW)

IE4

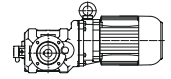

M <sub>N</sub> [Nm]	P <sub>N</sub> [kW]	n <sub>2</sub> [1/min]	M <sub>2</sub> [Nm]	f <sub>B</sub> [-]	i [:1]	IE- Classe	Type	Speed range n <sub>2</sub> [1/min]					Torque range M <sub>2</sub> [Nm]					m [kg]	F <sub>RN</sub> [N]	F <sub>RV</sub> [N]
								at engine speed n <sub>1</sub> [1/min]					at engine speed n <sub>1</sub> [1/min]							
								150	500	1000	1500	1800	150	500	1000	1500	1800			
35	5.5	189	250	1.3	7.91	IE5	BM30-../S5E11LA6	18.5	63	126	189	225	250	250	250	250	250	76	11000	13800
35	5.5	189	250	1.3	7.91	IE4	BM30-../S4E11MA6	18.5	63	126	189	225	192	215	250	250	250	65	11000	13800
35	5.5	149	320	1.1	10.06	IE4	BM30-../S4E11MA6	14.5	49.5	99	149	178	245	275	320	320	320	65	12000	15000
35	5.5	149	320	1.1	10.06	IE5	BM30-../S5E11LA6	14.5	49.5	99	149	178	320	320	320	320	320	76	12000	15000
35	5.5	120	400	0.87	12.46	IE4	BM30-../S4E11MA6	12	40	80	120	144	300	340	400	400	400	65	12000	15000
35	5.5	120	400	0.87	12.46	IE5	BM30-../S5E11LA6	12	40	80	120	144	400	400	400	400	400	76	12000	15000
35	5.5	134	350	1.8	11.17	IE4	BM40-../S4E11MA6	13	44.5	89	134	161	265	300	350	350	350	90	18300	22900
35	5.5	134	350	1.8	11.17	IE5	BM40-../S5E11LA6	13	44.5	89	134	161	350	350	350	350	350	102	18300	22900
35	5.5	103	455	1.5	14.5	IE4	BM40-../S4E11MA6	10	34	68	103	124	345	390	455	455	455	90	20000	25000
35	5.5	103	455	1.5	14.5	IE5	BM40-../S5E11LA6	10	34	68	103	124	455	455	455	455	455	102	20000	25000
35	5.5	83	560	1.2	18.05	IE5	BM40-../S5E11LA6	8.3	27.5	55	83	99	560	560	560	560	560	102	20000	25000
35	5.5	83	560	1.2	18.05	IE4	BM40-../S4E11MA6	8.3	27.5	55	83	99	430	485	560	560	560	90	20000	25000
35	5.5	66	700	0.96	22.44	IE5	BM40-../S5E11LA6	6.6	22	44.5	66	80	700	700	700	700	700	102	20000	25000
35	5.5	66	700	0.96	22.44	IE4	BM40-../S4E11MA6	6.6	22	44.5	66	80	530	600	700	700	700	90	20000	25000

### MN = 48 Nm (PN = 7.5 kW)

IE4

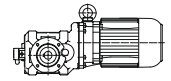

M <sub>N</sub> [Nm]	P <sub>N</sub> [kW]	n <sub>2</sub> [1/min]	M <sub>2</sub> [Nm]	f <sub>B</sub> [-]	i [:1]	IE- Classe	Type	Speed range n <sub>2</sub> [1/min]					Torque range M <sub>2</sub> [Nm]					m [kg]	F <sub>RN</sub> [N]	F <sub>RV</sub> [N]
								at engine speed n <sub>1</sub> [1/min]					at engine speed n <sub>1</sub> [1/min]							
								150	500	1000	1500	1800	150	500	1000	1500	1800			
48	7.5	189	345	0.92	7.91	IE3	BM30-../SPE11LA6	18.5	63	126	189	225	250	290	345	345	345	76	11000	13800
48	7.5	134	480	1.3	11.17	IE3	BM40-../SPE11LA6	13	44.5	89	134	161	350	400	480	480	480	102	18300	22900
48	7.5	103	620	1.1	14.5	IE3	BM40-../SPE11LA6	10	34	68	103	124	455	520	620	620	620	102	20000	25000
48	7.5	83	770	0.87	18.05	IE3	BM40-../SPE11LA6	8.3	27.5	55	83	99	560	640	770	770	770	102	20000	25000



# Geared motors for electric overhead conveyors series BM

## Selection table asynchronous motors PMSM IE4 3000 1/min

### MN = 0.65 Nm (PN = 0.2 kW)

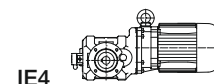

M <sub>N</sub>	P <sub>N</sub>	n <sub>2</sub>	M <sub>2</sub>	f <sub>B</sub>	i	IE- Classe	Type	Speed range n <sub>2</sub> [1/min]					Torque range M <sub>2</sub> [Nm]					m	F <sub>RN</sub>	FRV
								at engine speed n <sub>1</sub> [1/min]					at engine speed n <sub>1</sub> [1/min]							
[Nm]	[kW]	[1/min]	[Nm]	[--]	[:1]			150	500	1000	3000	3600	150	500	1000	3000	3600	[kg]	[N]	[N]
0.65	0.2	33	53	2.8	90.78	IE5	BM10G06-../S5E04SA4-1	1.6	5.5	11	33	39.5	53	53	53	53	53	23	8000	10000
0.65	0.2	29	58	2.6	102.7	IE5	BM10G06-../S5E04SA4-1	1.4	4.8	9.7	29	35	58	58	58	58	58	23	8000	10000
0.65	0.2	24.5	68	2.2	120.5	IE5	BM10G06-../S5E04SA4-1	1.2	4.1	8.2	24.5	29.5	68	68	68	68	68	23	8000	10000
0.65	0.2	22	76	2.1	133.7	IE5	BM10G06-../S5E04SA4-1	1.1	3.7	7.4	22	26.5	76	76	76	76	76	23	8000	10000
0.65	0.2	19.5	84	1.8	150.7	IE5	BM10G06-../S5E04SA4-1	0.95	3.3	6.6	19.5	23.5	84	84	84	84	84	23	8000	10000
0.65	0.2	17.5	93	1.7	167.2	IE5	BM10G06-../S5E04SA4-1	0.85	2.9	5.9	17.5	21.5	93	93	93	93	93	23	8000	10000
0.65	0.2	15.5	108	1.4	189.8	IE5	BM10G06-../S5E04SA4-1	0.75	2.6	5.2	15.5	18.5	108	108	108	108	108	23	8000	10000
0.65	0.2	13.5	122	1.3	219.4	IE5	BM10G06-../S5E04SA4-1	0.65	2.2	4.5	13.5	16	122	122	122	122	122	23	8000	10000
0.65	0.2	11.5	144	1.1	258.1	IE5	BM10G06-../S5E04SA4-1	0.55	1.9	3.8	11.5	13.5	144	144	144	144	144	23	8000	10000
0.65	0.2	9.7	172	0.93	308.9	IE5	BM10G06-../S5E04SA4-1	0.48	1.6	3.2	9.7	11.5	172	172	172	172	172	23	8000	10000
0.65	0.2	8.6	193	0.83	345.4	IE5	BM10G06-../S5E04SA4-1	0.43	1.4	2.8	8.6	10	193	193	193	193	193	23	8000	10000
0.65	0.2	25	72	3	117.9	IE5	BM20Z-../S5E04SA4-1	1.2	4.2	8.4	25	30.5	72	72	72	72	72	21	12000	12000
0.65	0.2	21	88	2.5	142.8	IE5	BM20Z-../S5E04SA4-1	1	3.5	7	21	25	88	88	88	88	88	21	12000	12000
0.65	0.2	16.5	110	1.9	178.9	IE5	BM20Z-../S5E04SA4-1	0.8	2.7	5.5	16.5	20	110	110	110	110	110	21	12000	12000
0.65	0.2	14.5	126	1.5	205.3	IE5	BM20Z-../S5E04SA4-1	0.7	2.4	4.8	14.5	17.5	126	126	126	126	126	21	12000	12000
0.65	0.2	11.5	156	1.2	253	IE5	BM20Z-../S5E04SA4-1	0.55	1.9	3.9	11.5	14	156	156	156	156	156	21	12000	12000
0.65	0.2	14	123	2.8	208.6	IE5	BM30G06-../S5E04SA4-1	0.7	2.3	4.7	14	17	123	123	123	123	123	44	12000	15000
0.65	0.2	12	143	2.4	245.1	IE5	BM30G06-../S5E04SA4-1	0.6	2	4	12	14.5	143	143	143	143	143	44	12000	15000
0.65	0.2	10	168	2.1	288.3	IE5	BM30G06-../S5E04SA4-1	0.5	1.7	3.4	10	12	168	168	168	168	168	44	12000	15000
0.65	0.2	8.6	200	1.7	345.1	IE5	BM30G06-../S5E04SA4-1	0.43	1.4	2.8	8.6	10	200	200	200	200	200	44	12000	15000
0.65	0.2	7.7	225	1.6	385.8	IE5	BM30G06-../S5E04SA4-1	0.38	1.2	2.5	7.7	9.3	225	225	225	225	225	44	12000	15000
0.65	0.2	6.4	270	1.3	463.9	IE5	BM30G06-../S5E04SA4-1	0.32	1	2.1	6.4	7.7	270	270	270	270	270	44	12000	15000
0.65	0.2	5.6	310	1.1	533.9	IE5	BM30G06-../S5E04SA4-1	0.28	0.9	1.8	5.6	6.7	310	310	310	310	310	44	12000	15000
0.65	0.2	4.5	385	0.9	663.4	IE5	BM30G06-../S5E04SA4-1	0.22	0.75	1.5	4.5	5.4	385	385	385	385	385	44	12000	15000

### MN = 0.8 Nm (PN = 0.25 kW)

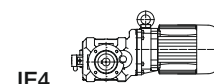

M <sub>N</sub>	P <sub>N</sub>	n <sub>2</sub>	M <sub>2</sub>	f <sub>B</sub>	i	IE- Classe	Type	Speed range n <sub>2</sub> [1/min]					Torque range M <sub>2</sub> [Nm]					m	F <sub>RN</sub>	FRV
								at engine speed n <sub>1</sub> [1/min]					at engine speed n <sub>1</sub> [1/min]							
[Nm]	[kW]	[1/min]	[Nm]	[--]	[:1]			150	500	1000	3000	3600	150	500	1000	3000	3600	[kg]	[N]	[N]
0.8	0.25	43	50	2.8	69.61	IE5	BM10G06-../S5E04SA4-1	2.1	7.1	14	43	51	48	50	50	50	50	23	8000	10000
0.8	0.25	40	52	2.7	74.41	IE5	BM10G06-../S5E04SA4-1	2	6.7	13	40	48	50	52	52	52	52	23	8000	10000
0.8	0.25	36	58	2.6	82.54	IE5	BM10G06-../S5E04SA4-1	1.8	6	12	36	43.5	55	58	58	58	58	23	8000	10000
0.8	0.25	33	66	2.3	90.78	IE5	BM10G06-../S5E04SA4-1	1.6	5.5	11	33	39.5	62	66	66	66	66	23	8000	10000
0.8	0.25	29	72	2.1	102.7	IE5	BM10G06-../S5E04SA4-1	1.4	4.8	9.7	29	35	68	72	72	72	72	23	8000	10000
0.8	0.25	24.5	84	1.8	120.5	IE5	BM10G06-../S5E04SA4-1	1.2	4.1	8.2	24.5	29.5	80	84	84	84	84	23	8000	10000
0.8	0.25	22	94	1.7	133.7	IE5	BM10G06-../S5E04SA4-1	1.1	3.7	7.4	22	26.5	89	94	94	94	94	23	8000	10000
0.8	0.25	19.5	103	1.4	150.7	IE5	BM10G06-../S5E04SA4-1	0.95	3.3	6.6	19.5	23.5	98	103	103	103	103	23	8000	10000
0.8	0.25	17.5	115	1.4	167.2	IE5	BM10G06-../S5E04SA4-1	0.85	2.9	5.9	17.5	21.5	109	115	115	115	115	23	8000	10000
0.8	0.25	15.5	133	1.1	189.8	IE5	BM10G06-../S5E04SA4-1	0.75	2.6	5.2	15.5	18.5	126	133	133	133	133	23	8000	10000
0.8	0.25	13.5	150	1.1	219.4	IE5	BM10G06-../S5E04SA4-1	0.65	2.2	4.5	13.5	16	143	150	150	150	150	23	8000	10000
0.8	0.25	11.5	177	0.9	258.1	IE5	BM10G06-../S5E04SA4-1	0.55	1.9	3.8	11.5	13.5	168	177	177	177	177	23	8000	10000
0.8	0.25	30	75	2.9	99.47	IE5	BM20Z-../S5E04SA4-1	1.5	5	10	30	36	71	75	75	75	75	21	12000	12000
0.8	0.25	25	89	2.5	117.9	IE5	BM20Z-../S5E04SA4-1	1.2	4.2	8.4	25	30.5	85	89	89	89	89	21	12000	12000
0.8	0.25	21	108	2	142.8	IE5	BM20Z-../S5E04SA4-1	1	3.5	7	21	25	103	108	108	108	108	21	12000	12000
0.8	0.25	16.5	135	1.5	178.9	IE5	BM20Z-../S5E04SA4-1	0.8	2.7	5.5	16.5	20	129	135	135	135	135	21	12000	12000
0.8	0.25	14.5	156	1.2	205.3	IE5	BM20Z-../S5E04SA4-1	0.7	2.4	4.8	14.5	17.5	148	156	156	156	156	21	12000	12000
0.8	0.25	11.5	192	0.95	253	IE5	BM20Z-../S5E04SA4-1	0.55	1.9	3.9	11.5	14	182	192	192	192	192	21	12000	12000
0.8	0.25	16	134	2.6	186.7	IE5	BM30G06-../S5E04SA4-1	0.8	2.6	5.3	16	19	127	134	134	134	134	44	12000	15000
0.8	0.25	14	151	2.3	208.6	IE5	BM30G06-../S5E04SA4-1	0.7	2.3	4.7	14	17	144	151	151	151	151	44	12000	15000
0.8	0.25	12	176	2	245.1	IE5	BM30G06-../S5E04SA4-1	0.6	2	4	12	14.5	167	176	176	176	176	44	12000	15000
0.8	0.25	10	205	1.7	288.3	IE5	BM30G06-../S5E04SA4-1	0.5	1.7	3.4	10	12	197	205	205	205	205	44	12000	15000
0.8	0.25	8.6	245	1.4	345.1	IE5	BM30G06-../S5E04SA4-1	0.43	1.4	2.8	8.6	10	235	245	245	245	245	44	12000	15000
0.8	0.25	7.7	275	1.3	385.8	IE5	BM30G06-../S5E04SA4-1	0.38	1.2	2.5	7.7	9.3	260	275	275	275	275	44	12000	15000
0.8	0.25	6.4	330	1	463.9	IE5	BM30G06-../S5E04SA4-1	0.32	1	2.1	6.4	7.7	315	330	330	330	330	44	12000	15000
0.8	0.25	5.6	380	0.91	533.9	IE5	BM30G06-../S5E04SA4-1	0.28	0.9	1.8	5.6	6.7	365	380	380	380	380	44	12000	15000

### MN = 1 Nm (PN = 0.315 kW)

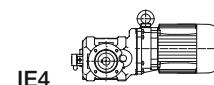

M <sub>N</sub>	P <sub>N</sub>	n <sub>2</sub>	M <sub>2</sub>	f <sub>B</sub>	i	IE- Classe	Type	Speed range n <sub>2</sub> [1/min]					Torque range M <sub>2</sub> [Nm]					m	F <sub>RN</sub>	FRV	
								at engine speed n <sub>1</sub> [1/min]					at engine speed n <sub>1</sub> [1/min]								
[Nm]	[kW]	[1/min]	[Nm]	[--]	[:1]			150	500	1000	3000	3600	150	500	1000	3000	3600	[kg]	[N]	[N]	
1	0.315	56	48	2.9	53.03	IE4	BM10G06-../S4E04SA4-1	2.8	9.4	18.5	56	67	36.5	41	48	48	48	48	23	8000	10000
1	0.315	51	53	2.8	58.79	IE4	BM10G06-../S4E04SA4-1	2.5	8.5	17	51	61	40.5	45	53	53	53	53	23	8000	10000
1	0.315	43	63	2.2	69.61	IE4	BM10G06-../S4E04SA4-1	2.1	7.1	14	43	51	48	53	63	63	63	63	23	8000	10000
1	0.315	40	66	2.2	74.41	IE4	BM10G06-../S4E04SA4-1	2	6.7	13	40	48	50	56	66	66	66	66	23	8000	10000
1	0.315	36	73	2.1	82.54	IE4	BM10G06-../S4E04SA4-1	1.8	6	12	36	43.5	55	62	73	73	73	73	23	8000	10000
1	0.315	33	82	1.8	90.78	IE4	BM10G06-../S4E04SA4-1	1.6	5.5	11	33	39.5	62	70	82	82	82	82	23	8000	

# Geared motors for electric overhead conveyors series BM

## Selection table asynchronous motors PMSM IE4 3000 1/min

### MN = 1 Nm (PN = 0.315 kW)

IE4

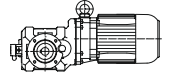

M <sub>N</sub>	P <sub>N</sub>	n <sub>2</sub>	M <sub>2</sub>	f <sub>B</sub>	i	IE- Class	Type	Speed range n <sub>2</sub> [1/min]					Torque range M <sub>2</sub> [Nm]					m	F <sub>RN</sub>	FRV
								at engine speed n <sub>1</sub> [1/min]					at engine speed n <sub>1</sub> [1/min]							
								150	500	1000	3000	3600	150	500	1000	3000	3600			
1	0.315	29	90	1.7	102.7	IE4	BM10G06-../S4E04SA4-1	1.4	4.8	9.7	29	35	68	76	90	90	90	23	8000	10000
1	0.315	24.5	106	1.4	120.5	IE4	BM10G06-../S4E04SA4-1	1.2	4.1	8.2	24.5	29.5	80	90	106	106	106	23	8000	10000
1	0.315	22	117	1.4	133.7	IE4	BM10G06-../S4E04SA4-1	1.1	3.7	7.4	22	26.5	89	100	117	117	117	23	8000	10000
1	0.315	19.5	129	1.2	150.7	IE4	BM10G06-../S4E04SA4-1	0.95	3.3	6.6	19.5	23.5	98	110	129	129	129	23	8000	10000
1	0.315	17.5	143	1.1	167.2	IE4	BM10G06-../S4E04SA4-1	0.85	2.9	5.9	17.5	21.5	109	122	143	143	143	23	8000	10000
1	0.315	15.5	167	0.9	189.8	IE4	BM10G06-../S4E04SA4-1	0.75	2.6	5.2	15.5	18.5	126	141	167	167	167	23	8000	10000
1	0.315	13.5	188	0.85	219.4	IE4	BM10G06-../S4E04SA4-1	0.65	2.2	4.5	13.5	16	143	160	188	188	188	23	8000	10000
1	0.315	35	81	2.7	85.45	IE4	BM20Z-../S4E04SA4-1	1.7	5.8	11.5	35	42	61	69	81	81	81	21	12000	12000
1	0.315	30	94	2.3	99.47	IE4	BM20Z-../S4E04SA4-1	1.5	5	10	30	36	71	80	94	94	94	21	12000	12000
1	0.315	25	112	2	117.9	IE4	BM20Z-../S4E04SA4-1	1.2	4.2	8.4	25	30.5	85	95	112	112	112	21	12000	12000
1	0.315	21	135	1.6	142.8	IE4	BM20Z-../S4E04SA4-1	1	3.5	7	21	25	103	115	135	135	135	21	12000	12000
1	0.315	16.5	169	1.2	178.9	IE4	BM20Z-../S4E04SA4-1	0.8	2.7	5.5	16.5	20	129	144	169	169	169	21	12000	12000
1	0.315	14.5	195	0.99	205.3	IE4	BM20Z-../S4E04SA4-1	0.7	2.4	4.8	14.5	17.5	148	165	195	195	195	21	12000	12000
1	0.315	16	168	2.1	186.7	IE4	BM30G06-../S4E04SA4-1	0.8	2.6	5.3	16	19	127	142	168	168	168	44	12000	15000
1	0.315	14	189	1.8	208.6	IE4	BM30G06-../S4E04SA4-1	0.7	2.3	4.7	14	17	144	161	189	189	189	44	12000	15000
1	0.315	12	220	1.6	245.1	IE4	BM30G06-../S4E04SA4-1	0.6	2	4	12	14.5	167	187	220	220	220	44	12000	15000
1	0.315	10	255	1.3	288.3	IE4	BM30G06-../S4E04SA4-1	0.5	1.7	3.4	10	12	197	220	255	255	255	44	12000	15000
1	0.315	8.6	310	1.1	345.1	IE4	BM30G06-../S4E04SA4-1	0.43	1.4	2.8	8.6	10	235	260	310	310	310	44	12000	15000
1	0.315	7.7	345	1	385.8	IE4	BM30G06-../S4E04SA4-1	0.38	1.2	2.5	7.7	9.3	260	295	345	345	345	44	12000	15000
1	0.315	6.4	415	0.84	463.9	IE4	BM30G06-../S4E04SA4-1	0.32	1	2.1	6.4	7.7	315	350	415	415	415	44	12000	15000

### MN = 1.3 Nm (PN = 0.4 kW)

IE4

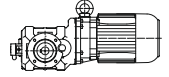

M <sub>N</sub>	P <sub>N</sub>	n <sub>2</sub>	M <sub>2</sub>	f <sub>B</sub>	i	IE- Class	Type	Speed range n <sub>2</sub> [1/min]					Torque range M <sub>2</sub> [Nm]					m	F <sub>RN</sub>	FRV
								at engine speed n <sub>1</sub> [1/min]					at engine speed n <sub>1</sub> [1/min]							
								150	500	1000	3000	3600	150	500	1000	3000	3600			
1.3	0.4	260	12.9	2.3	11.34	IE5	BM09-../S5E06MA4	13	44	88	260	315	12.9	12.9	12.9	12.9	12.9	14	4400	6500
1.3	0.4	225	15.1	2.1	13.23	IE5	BM09-../S5E06MA4	11	37.5	75	225	270	15.1	15.1	15.1	15.1	15.1	14	4400	6500
1.3	0.4	169	20	2.3	17.73	IE5	BM09-../S5E06MA4	8.4	28	56	169	200	20	20	20	20	20	14	4400	6500
1.3	0.4	141	24	2.3	21.2	IE5	BM09-../S5E06MA4	7	23.5	47	141	169	24	24	24	24	24	14	4400	6500
1.3	0.4	121	28	2.1	24.74	IE5	BM09-../S5E06MA4	6	20	40	121	145	28	28	28	28	28	14	4400	6500
1.3	0.4	115	29.5	2.3	25.98	IE5	BM09-../S5E06MA4	5.7	19	38	115	138	29.5	29.5	29.5	29.5	29.5	14	4400	6500
1.3	0.4	98	34.5	2.1	30.31	IE5	BM09-../S5E06MA4	4.9	16	32.5	98	118	34.5	34.5	34.5	34.5	34.5	14	4400	6500
1.3	0.4	90	37.5	2.3	32.97	IE5	BM09-../S5E06MA4	4.5	15	30	90	109	37.5	37.5	37.5	37.5	37.5	14	4400	6500
1.3	0.4	78	43.5	2.1	38.46	IE5	BM09-../S5E06MA4	3.9	13	26	78	93	43.5	43.5	43.5	43.5	43.5	14	4400	6500
1.3	0.4	70	47.5	1.8	42.44	IE5	BM09-../S5E06MA4	3.5	11.5	23.5	70	84	47.5	47.5	47.5	47.5	47.5	14	4400	6500
1.3	0.4	55	60	1.8	53.85	IE5	BM09-../S5E06MA4	2.7	9.2	18.5	55	66	60	60	60	60	60	14	4400	6500
1.3	0.4	57	55	2.7	52.44	IE5	BM10-../S5E06MA4	2.8	9.5	19	57	68	55	55	55	55	55	21	8000	10000
1.3	0.4	51	62	2.6	58.18	IE5	BM10-../S5E06MA4	2.5	8.5	17	51	61	62	62	62	62	62	21	8000	10000
1.3	0.4	67	52	2.7	44.15	IE5	BM10G06-../S5E06MA4	3.3	11	22.5	67	81	52	52	52	52	52	26	8000	10000
1.3	0.4	56	62	2.2	53.03	IE5	BM10G06-../S5E06MA4	2.8	9.4	18.5	56	67	62	62	62	62	62	26	8000	10000
1.3	0.4	51	69	2.2	58.79	IE5	BM10G06-../S5E06MA4	2.5	8.5	17	51	61	69	69	69	69	69	26	8000	10000
1.3	0.4	43	82	1.7	69.61	IE5	BM10G06-../S5E06MA4	2.1	7.1	14	43	51	82	82	82	82	82	26	8000	10000
1.3	0.4	40	86	1.7	74.41	IE5	BM10G06-../S5E06MA4	2	6.7	13	40	48	86	86	86	86	86	26	8000	10000
1.3	0.4	36	95	1.6	82.54	IE5	BM10G06-../S5E06MA4	1.8	6	12	36	43.5	95	95	95	95	95	26	8000	10000
1.3	0.4	33	107	1.4	90.78	IE5	BM10G06-../S5E06MA4	1.6	5.5	11	33	39.5	107	107	107	107	107	26	8000	10000
1.3	0.4	29	117	1.3	102.7	IE5	BM10G06-../S5E06MA4	1.4	4.8	9.7	29	35	117	117	117	117	117	26	8000	10000
1.3	0.4	24.5	137	1.1	120.5	IE5	BM10G06-../S5E06MA4	1.2	4.1	8.2	24.5	29.5	137	137	137	137	137	26	8000	10000
1.3	0.4	22	152	1	133.7	IE5	BM10G06-../S5E06MA4	1.1	3.7	7.4	22	26.5	152	152	152	152	152	26	8000	10000
1.3	0.4	19.5	168	0.89	150.7	IE5	BM10G06-../S5E06MA4	0.95	3.3	6.6	19.5	23.5	168	168	168	168	168	26	8000	10000
1.3	0.4	17.5	186	0.86	167.2	IE5	BM10G06-../S5E06MA4	0.85	2.9	5.9	17.5	21.5	186	186	186	186	186	26	8000	10000
1.3	0.4	49	74	2.6	60.64	IE5	BM20-../S5E06MA4	2.4	8.2	16	49	59	74	74	74	74	74	23	12000	12000
1.3	0.4	40	92	2	74.76	IE5	BM20-../S5E06MA4	2	6.6	13	40	48	92	92	92	92	92	23	12000	12000
1.3	0.4	44.5	82	2.7	66.74	IE5	BM20Z-../S5E06MA4	2.2	7.4	14.5	44.5	53	82	82	82	82	82	24	12000	12000
1.3	0.4	35	105	2.1	85.45	IE5	BM20Z-../S5E06MA4	1.7	5.8	11.5	35	42	105	105	105	105	105	24	12000	12000
1.3	0.4	30	122	1.8	99.47	IE5	BM20Z-../S5E06MA4	1.5	5	10	30	36	122	122	122	122	122	24	12000	12000
1.3	0.4	25	145	1.5	117.9	IE5	BM20Z-../S5E06MA4	1.2	4.2	8.4	25	30.5	145	145	145	145	145	24	12000	12000
1.3	0.4	21	176	1.2	142.8	IE5	BM20Z-../S5E06MA4	1	3.5	7	21	25	176	176	176	176	176	24	12000	12000
1.3	0.4	16.5	220	0.95	178.9	IE5	BM20Z-../S5E06MA4	0.8	2.7	5.5	16.5	20	220	220	220	220	220	24	12000	12000
1.3	0.4	23	143	2.4	128.2	IE5	BM30Z-../S5E06MA4	1.1	3.9	7.8	23	28	143	143	143	143	143	41	12000	1

# Geared motors for electric overhead conveyors series BM

## Selection table asynchronous motors PMSM IE4 3000 1/ min

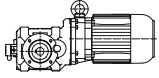
MN = 1.3 Nm (PN = 0.4 kW)																				
M <sub>N</sub>	P <sub>N</sub>	n <sub>2</sub>	M <sub>2</sub>	f <sub>B</sub>	i	IE- Classe	Type	Speed range n <sub>2</sub> [1/min]					Torque range M <sub>2</sub> [Nm]					m	F <sub>RN</sub>	F <sub>RV</sub>
								at engine speed n <sub>1</sub> [1/min]					at engine speed n <sub>1</sub> [1/min]							
								150	500	1000	3000	3600	150	500	1000	3000	3600			
1.3	0.4	6.9	445	1.1	430	IE5	BM40Z-../S5E06MA4	0.34	1.1	2.3	6.9	8.3	445	445	445	445	445	64	20000	25000
1.3	0.4	6.1	570	1.2	487.3	IE5	BM40G10-../S5E06MA4	0.3	1	2	6.1	7.3	570	570	570	570	570	68	20000	25000
1.3	0.4	5.5	630	1.1	540	IE5	BM40G10-../S5E06MA4	0.27	0.9	1.8	5.5	6.6	630	630	630	630	630	68	20000	25000
1.3	0.4	4.5	770	0.88	660.2	IE5	BM40G10-../S5E06MA4	0.22	0.75	1.5	4.5	5.4	770	770	770	770	770	68	20000	25000

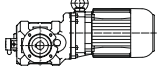
MN = 1.75 Nm (PN = 0.55 kW)																				
M <sub>N</sub>	P <sub>N</sub>	n <sub>2</sub>	M <sub>2</sub>	f <sub>B</sub>	i	IE- Classe	Type	Speed range n <sub>2</sub> [1/min]					Torque range M <sub>2</sub> [Nm]					m	F <sub>RN</sub>	F <sub>RV</sub>
								at engine speed n <sub>1</sub> [1/min]					at engine speed n <sub>1</sub> [1/min]							
								150	500	1000	3000	3600	150	500	1000	3000	3600			
1.75	0.55	260	17.4	1.7	11.34	IE5	BM09-../S5E06MA4	13	44	88	260	315	17.4	17.4	17.4	17.4	17.4	14	4400	6500
1.75	0.55	225	20	1.6	13.23	IE5	BM09-../S5E06MA4	11	37.5	75	225	270	20	20	20	20	20	14	4400	6500
1.75	0.55	169	27	1.7	17.73	IE5	BM09-../S5E06MA4	8.4	28	56	169	200	27	27	27	27	27	14	4400	6500
1.75	0.55	141	32.5	1.7	21.2	IE5	BM09-../S5E06MA4	7	23.5	47	141	169	32.5	32.5	32.5	32.5	32.5	14	4400	6500
1.75	0.55	121	38	1.5	24.74	IE5	BM09-../S5E06MA4	6	20	40	121	145	38	38	38	38	38	14	4400	6500
1.75	0.55	115	40	1.7	25.98	IE5	BM09-../S5E06MA4	5.7	19	38	115	138	40	40	40	40	40	14	4400	6500
1.75	0.55	98	46.5	1.5	30.31	IE5	BM09-../S5E06MA4	4.9	16	32.5	98	118	46.5	46.5	46.5	46.5	46.5	14	4400	6500
1.75	0.55	90	50	1.7	32.97	IE5	BM09-../S5E06MA4	4.5	15	30	90	109	50	50	50	50	50	14	4400	6500
1.75	0.55	78	59	1.6	38.46	IE5	BM09-../S5E06MA4	3.9	13	26	78	93	59	59	59	59	59	14	4400	6500
1.75	0.55	70	64	1.3	42.44	IE5	BM09-../S5E06MA4	3.5	11.5	23.5	70	84	64	64	64	64	64	14	4400	6500
1.75	0.55	55	81	1.3	53.85	IE5	BM09-../S5E06MA4	2.7	9.2	18.5	55	66	81	81	81	81	81	14	4400	6500
1.75	0.55	90	49.5	3	33.19	IE5	BM10-../S5E06MA4	4.5	15	30	90	108	49.5	49.5	49.5	49.5	49.5	21	8000	10000
1.75	0.55	81	55	2.9	36.82	IE5	BM10-../S5E06MA4	4	13.5	27	81	97	55	55	55	55	55	21	8000	10000
1.75	0.55	73	59	2.5	40.56	IE5	BM10-../S5E06MA4	3.6	12	24.5	73	88	59	59	59	59	59	21	8000	10000
1.75	0.55	66	66	2.4	45	IE5	BM10-../S5E06MA4	3.3	11	22	66	80	66	66	66	66	66	21	8000	10000
1.75	0.55	57	75	2	52.44	IE5	BM10-../S5E06MA4	2.8	9.5	19	57	68	75	75	75	75	75	21	8000	10000
1.75	0.55	51	83	1.9	58.18	IE5	BM10-../S5E06MA4	2.5	8.5	17	51	61	83	83	83	83	83	21	8000	10000
1.75	0.55	67	70	2	44.15	IE5	BM10G06-../S5E06MA4	3.3	11	22.5	67	81	70	70	70	70	70	26	8000	10000
1.75	0.55	56	84	1.7	53.03	IE5	BM10G06-../S5E06MA4	2.8	9.4	18.5	56	67	84	84	84	84	84	26	8000	10000
1.75	0.55	51	93	1.6	58.79	IE5	BM10G06-../S5E06MA4	2.5	8.5	17	51	61	93	93	93	93	93	26	8000	10000
1.75	0.55	43	110	1.3	69.61	IE5	BM10G06-../S5E06MA4	2.1	7.1	14	43	51	110	110	110	110	110	26	8000	10000
1.75	0.55	40	115	1.3	74.41	IE5	BM10G06-../S5E06MA4	2	6.7	13	40	48	115	115	115	115	115	26	8000	10000
1.75	0.55	36	128	1.2	82.54	IE5	BM10G06-../S5E06MA4	1.8	6	12	36	43.5	128	128	128	128	128	26	8000	10000
1.75	0.55	33	144	1	90.78	IE5	BM10G06-../S5E06MA4	1.6	5.5	11	33	39.5	144	144	144	144	144	26	8000	10000
1.75	0.55	29	158	0.95	102.7	IE5	BM10G06-../S5E06MA4	1.4	4.8	9.7	29	35	158	158	158	158	158	26	8000	10000
1.75	0.55	24.5	185	0.81	120.5	IE5	BM10G06-../S5E06MA4	1.2	4.1	8.2	24.5	29.5	185	185	185	185	185	26	8000	10000
1.75	0.55	56	87	2.4	52.84	IE5	BM20-../S5E06MA4	2.8	9.4	18.5	56	68	87	87	87	87	87	23	12000	12000
1.75	0.55	49	100	1.9	60.64	IE5	BM20-../S5E06MA4	2.4	8.2	16	49	59	100	100	100	100	100	23	12000	12000
1.75	0.55	40	124	1.5	74.76	IE5	BM20-../S5E06MA4	2	6.6	13	40	48	124	124	124	124	124	23	12000	12000
1.75	0.55	87	57	2.9	34.35	IE5	BM20Z-../S5E06MA4	4.3	14.5	29	87	104	57	57	57	57	57	24	12000	12000
1.75	0.55	66	75	2.9	45.15	IE5	BM20Z-../S5E06MA4	3.3	11	22	66	79	75	75	75	75	75	24	12000	12000
1.75	0.55	44.5	110	2	66.74	IE5	BM20Z-../S5E06MA4	2.2	7.4	14.5	44.5	53	110	110	110	110	110	24	12000	12000
1.75	0.55	35	142	1.5	85.45	IE5	BM20Z-../S5E06MA4	1.7	5.8	11.5	35	42	142	142	142	142	142	24	12000	12000
1.75	0.55	30	165	1.3	99.47	IE5	BM20Z-../S5E06MA4	1.5	5	10	30	36	165	165	165	165	165	24	12000	12000
1.75	0.55	25	196	1.1	117.9	IE5	BM20Z-../S5E06MA4	1.2	4.2	8.4	25	30.5	196	196	196	196	196	24	12000	12000
1.75	0.55	21	235	0.93	142.8	IE5	BM20Z-../S5E06MA4	1	3.5	7	21	25	235	235	235	235	235	24	12000	12000
1.75	0.55	48.5	94	2.9	61.33	IE5	BM30-../S5E06MA4	2.4	8.1	16	48.5	58	94	94	94	94	94	39	12000	15000
1.75	0.55	42	109	2.3	71.09	IE5	BM30-../S5E06MA4	2.1	7	14	42	50	109	109	109	109	109	39	12000	15000
1.75	0.55	34.5	130	2.7	85.96	IE5	BM30Z-../S5E06MA4	1.7	5.8	11.5	34.5	41.5	130	130	130	130	130	41	12000	15000
1.75	0.55	29.5	151	2.3	100.7	IE5	BM30Z-../S5E06MA4	1.4	4.9	9.9	29.5	35.5	151	151	151	151	151	41	12000	15000
1.75	0.55	23	192	1.8	128.2	IE5	BM30Z-../S5E06MA4	1.1	3.9	7.8	23	28	192	192	192	192	192	41	12000	15000
1.75	0.55	19.5	220	1.6	150.3	IE5	BM30Z-../S5E06MA4	0.95	3.3	6.6	19.5	23.5	220	220	220	220	220	41	12000	15000
1.75	0.55	16.5	260	1.3	177.2	IE5	BM30Z-../S5E06MA4	0.8	2.8	5.6	16.5	20	260	260	260	260	260	41	12000	15000
1.75	0.55	16	290	1.2	186.7	IE5	BM30G06-../S5E06MA4	0.8	2.6	5.3	16	19	290	290	290	290	290	47	12000	15000
1.75	0.55	14	330	1.1	208.6	IE5	BM30G06-../S5E06MA4	0.7	2.3	4.7	14	17	330	330	330	330	330	47	12000	15000
1.75	0.55	12	385	0.91	245.1	IE5	BM30G06-../S5E06MA4	0.6	2	4	12	14.5	385	385	385	385	385	47	12000	15000
1.75	0.55	17.5	245	2.8	169	IE5	BM40Z-../S5E06MA4	0.85	2.9	5.9	17.5	21	245	245	245	245	245	64	20000	25000
1.75	0.55	14	300	2.2	211.5	IE5	BM40Z-../S5E06MA4	0.7	2.3	4.7	14	17	300	300	300	300	300	64	20000	25000
1.75	0.55	12	345	1.9	246.6	IE5	BM40Z-../S5E06MA4	0.6	2	4	12	14.5	345	345	345	345	345	64	20000	25000
1.75	0.55	10	410	1.4	289.8	IE5	BM40Z-../S5E06MA4	0.5	1.7	3.4	10	12	410	410	410	410	410	64	20000	25000
1.75	0.55	8.6	490	1	348.7	IE5	BM40Z-../S5E06MA4	0.43	1.4											

# Geared motors for electric overhead conveyors series BM

## Selection table asynchronous motors PMSM IE4 3000 1/min

MN = 2.4 Nm (PN = 0.75 kW)

IE4

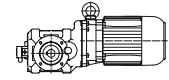

M <sub>N</sub> [Nm]	P <sub>N</sub> [kW]	n <sub>2</sub> [1/min]	M <sub>2</sub> [Nm]	f <sub>B</sub> [-]	i [1]	IE- Classe	Type	Speed range n <sub>2</sub> [1/min]					Torque range M <sub>2</sub> [Nm]					m [kg]	F <sub>RN</sub> [N]	F <sub>RV</sub> [N]
								at engine speed n <sub>1</sub> [1/min]					at engine speed n <sub>1</sub> [1/min]							
								150	500	1000	3000	3600	150	500	1000	3000	3600			
2.4	0.75	260	23.5	1.3	11.34	IE5	BM09-../S5E06LA4	13	44	88	260	315	23.5	23.5	23.5	23.5	23.5	14	4400	6500
2.4	0.75	260	23.5	1.3	11.34	IE3	BM09-../SPE06MA4	13	44	88	260	315	17.9	19.9	21.5	23.5	23.5	14	4400	6500
2.4	0.75	225	27.5	1.1	13.23	IE5	BM09-../S5E06LA4	11	37.5	75	225	270	27.5	27.5	27.5	27.5	27.5	14	4400	6500
2.4	0.75	225	27.5	1.1	13.23	IE3	BM09-../SPE06MA4	11	37.5	75	225	270	20.5	23	25.5	27.5	27.5	14	4400	6500
2.4	0.75	169	37	1.3	17.73	IE5	BM09-../S5E06LA4	8.4	28	56	169	200	37	37	37	37	37	14	4400	6500
2.4	0.75	169	37	1.3	17.73	IE3	BM09-../SPE06MA4	8.4	28	56	169	200	28	31	34	37	37	14	4400	6500
2.4	0.75	141	44.5	1.3	21.2	IE5	BM09-../S5E06LA4	7	23.5	47	141	169	44.5	44.5	44.5	44.5	44.5	14	4400	6500
2.4	0.75	141	44.5	1.3	21.2	IE3	BM09-../SPE06MA4	7	23.5	47	141	169	33.5	37	41	44.5	44.5	14	4400	6500
2.4	0.75	121	52	1.1	24.74	IE5	BM09-../S5E06LA4	6	20	40	121	145	52	52	52	52	52	14	4400	6500
2.4	0.75	121	52	1.1	24.74	IE3	BM09-../SPE06MA4	6	20	40	121	145	39	43.5	47.5	52	52	14	4400	6500
2.4	0.75	115	54	1.3	25.98	IE5	BM09-../S5E06LA4	5.7	19	38	115	138	54	54	54	54	54	14	4400	6500
2.4	0.75	115	54	1.3	25.98	IE3	BM09-../SPE06MA4	5.7	19	38	115	138	41	45.5	50	54	54	14	4400	6500
2.4	0.75	98	64	1.1	30.31	IE5	BM09-../S5E06LA4	4.9	16	32.5	98	118	64	64	64	64	64	14	4400	6500
2.4	0.75	98	64	1.1	30.31	IE3	BM09-../SPE06MA4	4.9	16	32.5	98	118	48	53	58	64	64	14	4400	6500
2.4	0.75	90	69	1.2	32.97	IE5	BM09-../S5E06LA4	4.5	15	30	90	109	69	69	69	69	69	14	4400	6500
2.4	0.75	90	69	1.2	32.97	IE3	BM09-../SPE06MA4	4.5	15	30	90	109	52	58	63	69	69	14	4400	6500
2.4	0.75	78	81	1.1	38.46	IE5	BM09-../S5E06LA4	3.9	13	26	78	93	81	81	81	81	81	14	4400	6500
2.4	0.75	78	81	1.1	38.46	IE3	BM09-../SPE06MA4	3.9	13	26	78	93	60	67	74	81	81	14	4400	6500
2.4	0.75	70	88	0.96	42.44	IE5	BM09-../S5E06LA4	3.5	11.5	23.5	70	84	88	88	88	88	88	14	4400	6500
2.4	0.75	70	88	0.96	42.44	IE3	BM09-../SPE06MA4	3.5	11.5	23.5	70	84	66	73	81	88	88	14	4400	6500
2.4	0.75	55	112	0.96	53.85	IE5	BM09-../S5E06LA4	2.7	9.2	18.5	55	66	112	112	112	112	112	14	4400	6500
2.4	0.75	55	112	0.96	53.85	IE3	BM09-../SPE06MA4	2.7	9.2	18.5	55	66	84	93	103	112	112	14	4400	6500
2.4	0.75	119	52	3	25.09	IE5	BM10-../S5E06LA4	5.9	19.5	39.5	119	143	52	52	52	52	52	21	8000	10000
2.4	0.75	119	52	3	25.09	IE3	BM10-../SPE06MA4	5.9	19.5	39.5	119	143	39.5	44	48.5	52	52	21	8000	10000
2.4	0.75	112	56	2.7	26.55	IE5	BM10-../S5E06LA4	5.6	18.5	37.5	112	135	56	56	56	56	56	21	8000	10000
2.4	0.75	112	56	2.7	26.55	IE3	BM10-../SPE06MA4	5.6	18.5	37.5	112	135	42	46.5	51	56	56	21	8000	10000
2.4	0.75	101	62	2.6	29.45	IE5	BM10-../S5E06LA4	5	16.5	33.5	101	122	62	62	62	62	62	21	8000	10000
2.4	0.75	101	62	2.6	29.45	IE3	BM10-../SPE06MA4	5	16.5	33.5	101	122	46.5	51	57	62	62	21	8000	10000
2.4	0.75	90	68	2.2	33.19	IE5	BM10-../S5E06LA4	4.5	15	30	90	108	68	68	68	68	68	21	8000	10000
2.4	0.75	90	68	2.2	33.19	IE3	BM10-../SPE06MA4	4.5	15	30	90	108	51	57	62	68	68	21	8000	10000
2.4	0.75	81	75	2.1	36.82	IE5	BM10-../S5E06LA4	4	13.5	27	81	97	75	75	75	75	75	21	8000	10000
2.4	0.75	81	75	2.1	36.82	IE3	BM10-../SPE06MA4	4	13.5	27	81	97	56	63	69	75	75	21	8000	10000
2.4	0.75	73	81	1.8	40.56	IE5	BM10-../S5E06LA4	3.6	12	24.5	73	88	81	81	81	81	81	21	8000	10000
2.4	0.75	73	81	1.8	40.56	IE3	BM10-../SPE06MA4	3.6	12	24.5	73	88	61	68	74	81	81	21	8000	10000
2.4	0.75	66	90	1.8	45	IE5	BM10-../S5E06LA4	3.3	11	22	66	80	90	90	90	90	90	21	8000	10000
2.4	0.75	66	90	1.8	45	IE3	BM10-../SPE06MA4	3.3	11	22	66	80	68	75	83	90	90	21	8000	10000
2.4	0.75	57	103	1.5	52.44	IE5	BM10-../S5E06LA4	2.8	9.5	19	57	68	103	103	103	103	103	21	8000	10000
2.4	0.75	57	103	1.5	52.44	IE3	BM10-../SPE06MA4	2.8	9.5	19	57	68	77	86	94	103	103	21	8000	10000
2.4	0.75	51	114	1.4	58.18	IE5	BM10-../S5E06LA4	2.5	8.5	17	51	61	114	114	114	114	114	21	8000	10000
2.4	0.75	51	114	1.4	58.18	IE3	BM10-../SPE06MA4	2.5	8.5	17	51	61	85	95	104	114	114	21	8000	10000
2.4	0.75	67	96	1.5	44.15	IE5	BM10G06-../S5E06LA4	3.3	11	22.5	67	81	96	96	96	96	96	26	8000	10000
2.4	0.75	67	96	1.5	44.15	IE3	BM10G06-../SPE06MA4	3.3	11	22.5	67	81	72	80	88	96	96	26	8000	10000
2.4	0.75	56	115	1.2	53.03	IE5	BM10G06-../S5E06LA4	2.8	9.4	18.5	56	67	115	115	115	115	115	26	8000	10000
2.4	0.75	56	115	1.2	53.03	IE3	BM10G06-../SPE06MA4	2.8	9.4	18.5	56	67	86	96	106	115	115	26	8000	10000
2.4	0.75	51	128	1.2	58.79	IE5	BM10G06-../S5E06LA4	2.5	8.5	17	51	61	128	128	128	128	128	26	8000	10000
2.4	0.75	51	128	1.2	58.79	IE3	BM10G06-../SPE06MA4	2.5	8.5	17	51	61	96	106	117	128	128	26	8000	10000
2.4	0.75	43	152	0.92	69.61	IE5	BM10G06-../S5E06LA4	2.1	7.1	14	43	51	152	152	152	152	152	26	8000	10000
2.4	0.75	43	152	0.92	69.61	IE3	BM10G06-../SPE06MA4	2.1	7.1	14	43	51	114	126	139	152	152	26	8000	10000
2.4	0.75	40	158	0.91	74.41	IE5	BM10G06-../S5E06LA4	2	6.7	13	40	48	158	158	158	158	158	26	8000	10000
2.4	0.75	40	158	0.91	74.41	IE3	BM10G06-../SPE06MA4	2	6.7	13	40	48	119	132	145	158	158	26	8000	10000
2.4	0.75	36	176	0.88	82.54	IE5	BM10G06-../S5E06LA4	1.8	6	12	36	43.5	176	176	176	176	176	26	8000	10000
2.4	0.75	36	176	0.88	82.54	IE3	BM10G06-../SPE06MA4	1.8	6	12	36	43.5	132	146	161	176	176	26	8000	10000
2.4	0.75	85	80	2.7	35.25	IE5	BM20-../S5E06LA4	4.2	14	28	85	102	80	80	80	80	80	23	12000	12000
2.4	0.75	85	80	2.7	35.25	IE3	BM20-../SPE06MA4	4.2	14	28	85	102	60	66	73	80	80	23	12000	12000
2.4	0.75	71	96	2.3	42.18	IE5	BM20-../S5E06LA4	3.5	11.5	23.5	71	85	96	96	96	96	96	23	12000	12000
2.4	0.75	71	96	2.3	42.18	IE3	BM20-../SPE06MA4	3.5	11.5	23.5	71	85	72	80	88	96	96	23	12000	12000
2.4	0.75	56	120	1.7	52.84	IE5	BM20-../S5E06LA4	2.8	9.4	18.5	56	68	120	120	120	120	120	23	12000	12000
2.4	0.75	56	120	1.7	52.84	IE3	BM20-../SPE06MA4	2.8	9.4	18.5	56	68	90	100	110	120	120	23	12000	12000
2.4	0.75	49	138	1.4	60.64	IE5	BM20-../S5E06LA4	2.4	8.2	16	49	59	138	138	138	138	138	23	12000	12000
2.4	0.75	49	138	1.4	60.64	IE3	BM20-../SPE06MA4	2.4	8.2	16	49	59	103	115	126	138	138	23	12000	12000
2.4	0.75	40	170	1.1	74.76	IE5	BM20-../S5E06LA4	2	6.6	13	40	48	170	170	170	170	170	23	12000	12000
2.4	0.75	40	170	1.1	74.76	IE3	BM20-../SPE06MA4	2	6.6	13	40	48	127	142	156	170	170	23	12000	12000
2.4	0.75	87	78	2.1	34.35	IE5	BM20Z-../S5E06LA4	4.3	14.5	29	87	104	78	78	78	78	78	24	12000	12000
2.4	0.75	87	78	2.1	34.35	IE3	BM20Z-../SPE06MA4	4.3	14.5	29	87	104	58	65	71	78	78	24	12000	12000
2.4	0.75	66	102	2.1	45.15	IE5	BM20Z-../S5E06LA4	3.3	11	22	66	79	102	102	102	102	102			



# Geared motors for electric overhead conveyors series BM

## Selection table asynchronous motors PMSM IE4 3000 1/ min

### MN = 2.4 Nm (PN = 0.75 kW)

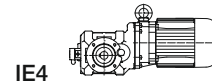

M <sub>N</sub>	P <sub>N</sub>	n <sub>2</sub>	M <sub>2</sub>	f <sub>B</sub>	i	IE- Classe	Type	Speed range n <sub>2</sub> [1/min]					Torque range M <sub>2</sub> [Nm]					m	F <sub>RN</sub>	FRV
								at engine speed n <sub>1</sub> [1/min]					at engine speed n <sub>1</sub> [1/min]							
								150	500	1000	3000	3600	150	500	1000	3000	3600			
2.4	0.75	55	112	2.5	53.67	IE5	BM30Z-../S5E06LA4	2.7	9.3	18.5	55	67	112	112	112	112	112	41	12000	15000
2.4	0.75	55	112	2.5	53.67	IE3	BM30Z-../SPE06MA4	2.7	9.3	18.5	55	67	84	93	102	112	112	41	12000	15000
2.4	0.75	43	144	2.4	69.35	IE5	BM30Z-../S5E06LA4	2.1	7.2	14	43	51	144	144	144	144	144	41	12000	15000
2.4	0.75	43	144	2.4	69.35	IE3	BM30Z-../SPE06MA4	2.1	7.2	14	43	51	108	120	132	144	144	41	12000	15000
2.4	0.75	34.5	179	2	85.96	IE5	BM30Z-../S5E06LA4	1.7	5.8	11.5	34.5	41.5	179	179	179	179	179	41	12000	15000
2.4	0.75	34.5	179	2	85.96	IE3	BM30Z-../SPE06MA4	1.7	5.8	11.5	34.5	41.5	134	149	164	179	179	41	12000	15000
2.4	0.75	29.5	205	1.7	100.7	IE5	BM30Z-../S5E06LA4	1.4	4.9	9.9	29.5	35.5	205	205	205	205	205	41	12000	15000
2.4	0.75	29.5	205	1.7	100.7	IE3	BM30Z-../SPE06MA4	1.4	4.9	9.9	29.5	35.5	155	173	190	205	205	41	12000	15000
2.4	0.75	23	260	1.3	128.2	IE5	BM30Z-../S5E06LA4	1.1	3.9	7.8	23	28	260	260	260	260	260	41	12000	15000
2.4	0.75	23	260	1.3	128.2	IE3	BM30Z-../SPE06MA4	1.1	3.9	7.8	23	28	198	220	240	260	260	41	12000	15000
2.4	0.75	19.5	305	1.1	150.3	IE5	BM30Z-../S5E06LA4	0.95	3.3	6.6	19.5	23.5	305	305	305	305	305	41	12000	15000
2.4	0.75	19.5	305	1.1	150.3	IE3	BM30Z-../SPE06MA4	0.95	3.3	6.6	19.5	23.5	225	255	280	305	305	41	12000	15000
2.4	0.75	16.5	360	0.97	177.2	IE5	BM30Z-../S5E06LA4	0.8	2.8	5.6	16.5	20	360	360	360	360	360	41	12000	15000
2.4	0.75	16.5	360	0.97	177.2	IE3	BM30Z-../SPE06MA4	0.8	2.8	5.6	16.5	20	270	300	330	360	360	41	12000	15000
2.4	0.75	16	400	0.87	186.7	IE5	BM30G06-../S5E06LA4	0.8	2.6	5.3	16	19	400	400	400	400	400	47	12000	15000
2.4	0.75	16	400	0.87	186.7	IE3	BM30G06-../SPE06MA4	0.8	2.6	5.3	16	19	300	335	365	400	400	47	12000	15000
2.4	0.75	25	240	2.8	118.2	IE5	BM40Z-../S5E06LA4	1.2	4.2	8.4	25	30	240	240	240	240	240	64	20000	25000
2.4	0.75	25	240	2.8	118.2	IE3	BM40Z-../SPE06MA4	1.2	4.2	8.4	25	30	180	200	220	240	240	64	20000	25000
2.4	0.75	20.5	285	2.4	143	IE5	BM40Z-../S5E06LA4	1	3.4	6.9	20.5	25	285	285	285	285	285	64	20000	25000
2.4	0.75	20.5	285	2.4	143	IE3	BM40Z-../SPE06MA4	1	3.4	6.9	20.5	25	215	240	260	285	285	64	20000	25000
2.4	0.75	17.5	335	2	169	IE5	BM40Z-../S5E06LA4	0.85	2.9	5.9	17.5	21	335	335	335	335	335	64	20000	25000
2.4	0.75	17.5	335	2	169	IE3	BM40Z-../SPE06MA4	0.85	2.9	5.9	17.5	21	250	280	305	335	335	64	20000	25000
2.4	0.75	14	415	1.6	211.5	IE5	BM40Z-../S5E06LA4	0.7	2.3	4.7	14	17	415	415	415	415	415	64	20000	25000
2.4	0.75	14	415	1.6	211.5	IE3	BM40Z-../SPE06MA4	0.7	2.3	4.7	14	17	310	345	380	415	415	64	20000	25000
2.4	0.75	12	475	1.4	246.6	IE5	BM40Z-../S5E06LA4	0.6	2	4	12	14.5	475	475	475	475	475	64	20000	25000
2.4	0.75	12	475	1.4	246.6	IE3	BM40Z-../SPE06MA4	0.6	2	4	12	14.5	355	395	435	475	475	64	20000	25000
2.4	0.75	10	560	1	289.8	IE5	BM40Z-../S5E06LA4	0.5	1.7	3.4	10	12	560	560	560	560	560	64	20000	25000
2.4	0.75	10	560	1	289.8	IE3	BM40Z-../SPE06MA4	0.5	1.7	3.4	10	12	420	465	510	560	560	64	20000	25000

### MN = 3.5 Nm (PN = 1.1 kW)

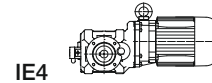

M <sub>N</sub>	P <sub>N</sub>	n <sub>2</sub>	M <sub>2</sub>	f <sub>B</sub>	i	IE- Classe	Type	Speed range n <sub>2</sub> [1/min]					Torque range M <sub>2</sub> [Nm]					m	F <sub>RN</sub>	FRV
								at engine speed n <sub>1</sub> [1/min]					at engine speed n <sub>1</sub> [1/min]							
								150	500	1000	3000	3600	150	500	1000	3000	3600			
3.5	1.1	260	34.5	0.86	11.34	IE4	BM09-../S4E06LA4	13	44	88	260	315	24.5	28.5	34.5	34.5	34.5	14	4400	6500
3.5	1.1	169	54	0.86	17.73	IE4	BM09-../S4E06LA4	8.4	28	56	169	200	39	45	54	54	54	14	4400	6500
3.5	1.1	141	65	0.86	21.2	IE4	BM09-../S4E06LA4	7	23.5	47	141	169	46.5	54	65	65	65	14	4400	6500
3.5	1.1	115	80	0.86	25.98	IE4	BM09-../S4E06LA4	5.7	19	38	115	138	57	66	80	80	80	14	4400	6500
3.5	1.1	90	101	0.86	32.97	IE4	BM09-../S4E06LA4	4.5	15	30	90	109	72	84	101	101	101	14	4400	6500
3.5	1.1	132	69	2.2	22.62	IE4	BM10-../S4E06LA4	6.6	22	44	132	159	49.5	57	69	69	69	21	8000	10000
3.5	1.1	119	77	2.1	25.09	IE4	BM10-../S4E06LA4	5.9	19.5	39.5	119	143	55	64	77	77	77	21	8000	10000
3.5	1.1	112	81	1.8	26.55	IE4	BM10-../S4E06LA4	5.6	18.5	37.5	112	135	58	67	81	81	81	21	8000	10000
3.5	1.1	101	90	1.8	29.45	IE4	BM10-../S4E06LA4	5	16.5	33.5	101	122	64	75	90	90	90	21	8000	10000
3.5	1.1	90	99	1.5	33.19	IE4	BM10-../S4E06LA4	4.5	15	30	90	108	71	82	99	99	99	21	8000	10000
3.5	1.1	81	110	1.4	36.82	IE4	BM10-../S4E06LA4	4	13.5	27	81	97	79	91	110	110	110	21	8000	10000
3.5	1.1	73	119	1.3	40.56	IE4	BM10-../S4E06LA4	3.6	12	24.5	73	88	85	98	119	119	119	21	8000	10000
3.5	1.1	66	132	1.2	45	IE4	BM10-../S4E06LA4	3.3	11	22	66	80	94	109	132	132	132	21	8000	10000
3.5	1.1	57	150	1	52.44	IE4	BM10-../S4E06LA4	2.8	9.5	19	57	68	107	124	150	150	150	21	8000	10000
3.5	1.1	51	166	0.96	58.18	IE4	BM10-../S4E06LA4	2.5	8.5	17	51	61	119	138	166	166	166	21	8000	10000
3.5	1.1	67	140	1	44.15	IE4	BM10G06-../S4E06LA4	3.3	11	22.5	67	81	100	116	140	140	140	26	8000	10000
3.5	1.1	56	168	0.83	53.03	IE4	BM10G06-../S4E06LA4	2.8	9.4	18.5	56	67	120	139	168	168	168	26	8000	10000
3.5	1.1	51	187	0.8	58.79	IE4	BM10G06-../S4E06LA4	2.5	8.5	17	51	61	133	155	187	187	187	26	8000	10000
3.5	1.1	118	83	2.6	25.25	IE4	BM20-../S4E06LA4	5.9	19.5	39.5	118	142	59	69	83	83	83	23	12000	12000
3.5	1.1	102	97	2.3	29.39	IE4	BM20-../S4E06LA4	5.1	17	34	102	122	69	80	97	97	97	23	12000	12000
3.5	1.1	85	117	1.9	35.25	IE4	BM20-../S4E06LA4	4.2	14	28	85	102	83	97	117	117	117	23	12000	12000
3.5	1.1	71	140	1.6	42.18	IE4	BM20-../S4E06LA4	3.5	11.5	23.5	71	85	100	116	140	140	140	23	12000	12000
3.5	1.1	56	175	1.2	52.84	IE4	BM20-../S4E06LA4	2.8	9.4	18.5	56	68	125	145	175	175	175	23	12000	12000
3.5	1.1	49	200	0.96	60.64	IE4	BM20-../S4E06LA4	2.4	8.2	16	49	59	144	167	200	200	200	23	12000	12000
3.5	1.1	87	114	1.4	34.35	IE4	BM20Z-../S4E06LA4	4.3	14.5	29	87	104	81	94	114	114	114	24	12000	12000
3.5	1.1	66	150	1.4	45.15	IE4	BM20Z-../S4E06LA4	3.3	11	22	66	79	107	124	150	150	150	24	12000	12000
3.5	1.1	44.5	220	0.99	66.74	IE4	BM20Z-../S4E06LA4	2.2	7.4	14.5	44.5	53	158	183	220	220	220	24	12000	12000
3.5	1.1	72	129	2.7	41.13	IE4	BM30-../S4E06LA4	3.6	12	24	72	87	92	107	129	129	129	39	12000	15000
3.5	1.1	60	154	2	49.66	IE4	BM30-../S4E06LA4	3	10	20	60	72	110	128	154	154	154	39	12000	15000
3.5	1.1	48.5	188	1.4	61.33	IE4	BM30-../S4E06LA4	2.4	8.1	16	48.5	58	134	156	188	188	188	39	12000	15000
3.5	1.1	42	215	1.2	71.09	IE4	BM30-../S4E06LA4	2.1	7	14	42	50	156	181	215	215	215	39	12000	15000
3.5	1.1	55	163	1.7	53.67	IE4	BM30Z-../S4E06LA4	2.7	9.3	18.5	55	67	116	135	163	163	163	41	12000	15000
3.5	1.1	43	210	1.7	69.35	IE4	BM30Z-../S4E06LA4	2.1	7.2	14	43	51	150	174	210	210	210	41	12000	15000
3.5	1.1	34.5	260	1.3	85.96	IE4	BM30Z-../S4E06LA4	1.7	5.8	11.5	34.5	41.5	186	215	260	260	260	41	12000	15

# Geared motors for electric overhead conveyors series BM

## Selection table asynchronous motors PMSM IE4 3000 1/ min

### MN = 3.5 Nm (PN = 1.1 kW)

IE4

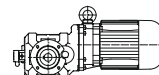

M <sub>N</sub> [Nm]	P <sub>N</sub> [kW]	n <sub>2</sub> [1/min]	M <sub>2</sub> [Nm]	f <sub>B</sub> [--]	i [1:1]	IE- Classe	Type	Speed range n <sub>2</sub> [1/min] at engine speed n <sub>1</sub> [1/min]					Torque range M <sub>2</sub> [Nm] at engine speed n <sub>1</sub> [1/min]					m [kg]	F <sub>RN</sub> [N]	FRV [N]
								150	500	1000	3000	3600	150	500	1000	3000	3600			
3.5	1.1	17.5	490	1.4	169	IE4	BM40Z-../S4E06LA4	0.85	2.9	5.9	17.5	21	350	405	490	490	490	64	20000	25000
3.5	1.1	14	600	1.1	211.5	IE4	BM40Z-../S4E06LA4	0.7	2.3	4.7	14	17	430	500	600	600	600	64	20000	25000
3.5	1.1	12	690	0.97	246.6	IE4	BM40Z-../S4E06LA4	0.6	2	4	12	14.5	495	570	690	690	690	64	20000	25000

### MN = 5 Nm (PN = 1.55 kW)

IE4

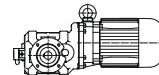

M <sub>N</sub> [Nm]	P <sub>N</sub> [kW]	n <sub>2</sub> [1/min]	M <sub>2</sub> [Nm]	f <sub>B</sub> [--]	i [1:1]	IE- Classe	Type	Speed range n <sub>2</sub> [1/min] at engine speed n <sub>1</sub> [1/min]					Torque range M <sub>2</sub> [Nm] at engine speed n <sub>1</sub> [1/min]					m [kg]	F <sub>RN</sub> [N]	FRV [N]
								150	500	1000	3000	3600	150	500	1000	3000	3600			
5	1.55	255	53	2.6	11.68	IE5	BM10-../S5E08MA4	12.5	42.5	85	255	305	53	53	53	53	53	24	8000	10000
5	1.55	230	58	2.5	12.95	IE5	BM10-../S5E08MA4	11.5	38.5	77	230	275	58	58	58	58	58	24	8000	10000
5	1.55	183	72	2	16.39	IE5	BM10-../S5E08MA4	9.1	30.5	61	183	215	72	72	72	72	72	24	8000	10000
5	1.55	165	80	1.9	18.18	IE5	BM10-../S5E08MA4	8.2	27.5	55	165	198	80	80	80	80	80	24	8000	10000
5	1.55	132	99	1.5	22.62	IE5	BM10-../S5E08MA4	6.6	22	44	132	159	99	99	99	99	99	24	8000	10000
5	1.55	119	110	1.4	25.09	IE5	BM10-../S5E08MA4	5.9	19.5	39.5	119	143	110	110	110	110	110	24	8000	10000
5	1.55	112	116	1.3	26.55	IE5	BM10-../S5E08MA4	5.6	18.5	37.5	112	135	116	116	116	116	116	24	8000	10000
5	1.55	101	129	1.2	29.45	IE5	BM10-../S5E08MA4	5	16.5	33.5	101	122	129	129	129	129	129	24	8000	10000
5	1.55	90	142	1.1	33.19	IE5	BM10-../S5E08MA4	4.5	15	30	90	108	142	142	142	142	142	24	8000	10000
5	1.55	81	158	1	36.82	IE5	BM10-../S5E08MA4	4	13.5	27	81	97	158	158	158	158	158	24	8000	10000
5	1.55	73	170	0.88	40.56	IE5	BM10-../S5E08MA4	3.6	12	24.5	73	88	170	170	170	170	170	24	8000	10000
5	1.55	66	189	0.85	45	IE5	BM10-../S5E08MA4	3.3	11	22	66	80	189	189	189	189	189	24	8000	10000
5	1.55	179	79	2.8	16.72	IE5	BM20-../S5E08MA4	8.9	29.5	59	179	215	79	79	79	79	79	26	12000	12000
5	1.55	152	93	2.3	19.72	IE5	BM20-../S5E08MA4	7.6	25	50	152	182	93	93	93	93	93	26	12000	12000
5	1.55	118	119	1.8	25.25	IE5	BM20-../S5E08MA4	5.9	19.5	39.5	118	142	119	119	119	119	119	26	12000	12000
5	1.55	102	139	1.6	29.39	IE5	BM20-../S5E08MA4	5.1	17	34	102	122	139	139	139	139	139	26	12000	12000
5	1.55	85	167	1.3	35.25	IE5	BM20-../S5E08MA4	4.2	14	28	85	102	167	167	167	167	167	26	12000	12000
5	1.55	71	200	1.1	42.18	IE5	BM20-../S5E08MA4	3.5	11.5	23.5	71	85	200	200	200	200	200	26	12000	12000
5	1.55	56	250	0.83	52.84	IE5	BM20-../S5E08MA4	2.8	9.4	18.5	56	68	250	250	250	250	250	26	12000	12000
5	1.55	87	163	1	34.35	IE5	BM20Z-../S5E08MA4	4.3	14.5	29	87	104	163	163	163	163	163	28	12000	12000
5	1.55	66	210	1	45.15	IE5	BM20Z-../S5E08MA4	3.3	11	22	66	79	210	210	210	210	210	28	12000	12000
5	1.55	100	135	2.6	29.76	IE5	BM30-../S5E08MA4	5	16.5	33.5	100	120	135	135	135	135	135	42	12000	15000
5	1.55	86	158	2.2	34.88	IE5	BM30-../S5E08MA4	4.3	14	28.5	86	103	158	158	158	158	158	42	12000	15000
5	1.55	72	185	1.9	41.13	IE5	BM30-../S5E08MA4	3.6	12	24	72	87	185	185	185	185	185	42	12000	15000
5	1.55	60	220	1.4	49.66	IE5	BM30-../S5E08MA4	3	10	20	60	72	220	220	220	220	220	42	12000	15000
5	1.55	48.5	265	1	61.33	IE5	BM30-../S5E08MA4	2.4	8.1	16	48.5	58	265	265	265	265	265	42	12000	15000
5	1.55	42	310	0.82	71.09	IE5	BM30-../S5E08MA4	2.1	7	14	42	50	310	310	310	310	310	42	12000	15000
5	1.55	55	230	1.2	53.67	IE5	BM30Z-../S5E08MA4	2.7	9.3	18.5	55	67	230	230	230	230	230	45	12000	15000
5	1.55	43	300	1.2	69.35	IE5	BM30Z-../S5E08MA4	2.1	7.2	14	43	51	300	300	300	300	300	45	12000	15000
5	1.55	34.5	370	0.94	85.96	IE5	BM30Z-../S5E08MA4	1.7	5.8	11.5	34.5	41.5	370	370	370	370	370	45	12000	15000
5	1.55	29.5	430	0.81	100.7	IE5	BM30Z-../S5E08MA4	1.4	4.9	9.9	29.5	35.5	430	430	430	430	430	45	12000	15000
5	1.55	58	225	3	51.18	IE5	BM40-../S5E08MA4	2.9	9.7	19.5	58	70	225	225	225	225	225	63	20000	25000
5	1.55	50	260	2.6	59.66	IE5	BM40-../S5E08MA4	2.5	8.3	16.5	50	60	260	260	260	260	260	63	20000	25000
5	1.55	42.5	300	2.2	70.11	IE5	BM40-../S5E08MA4	2.1	7.1	14	42.5	51	300	300	300	300	300	63	20000	25000
5	1.55	35.5	365	1.6	84.36	IE5	BM40-../S5E08MA4	1.7	5.9	11.5	35.5	42.5	365	365	365	365	365	63	20000	25000
5	1.55	28.5	440	1.4	104	IE5	BM40-../S5E08MA4	1.4	4.8	9.6	28.5	34.5	440	440	440	440	440	63	20000	25000
5	1.55	25	500	1.4	118.2	IE5	BM40Z-../S5E08MA4	1.2	4.2	8.4	25	30	500	500	500	500	500	67	20000	25000
5	1.55	20.5	600	1.1	143	IE5	BM40Z-../S5E08MA4	1	3.4	6.9	20.5	25	600	600	600	600	600	67	20000	25000
5	1.55	17.5	700	0.97	169	IE5	BM40Z-../S5E08MA4	0.85	2.9	5.9	17.5	21	700	700	700	700	700	67	20000	25000

### MN = 7 Nm (PN = 2.2 kW)

IE4

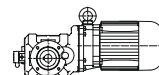

M <sub>N</sub> [Nm]	P <sub>N</sub> [kW]	n <sub>2</sub> [1/min]	M <sub>2</sub> [Nm]	f <sub>B</sub> [--]	i [1:1]	IE- Classe	Type	Speed range n <sub>2</sub> [1/min] at engine speed n <sub>1</sub> [1/min]					Torque range M <sub>2</sub> [Nm] at engine speed n <sub>1</sub> [1/min]					m [kg]	F <sub>RN</sub> [N]	FRV [N]
								150	500	1000	3000	3600	150	500	1000	3000	3600			
7	2.2	255	74	1.9	11.68	IE4	BM10-../S4E08MA4	12.5	42.5	85	255	305	53	62	74	74	74	24	8000	10000
7	2.2	255	74	1.9	11.68	IE5	BM10-../S5E08LA4	12.5	42.5	85	255	305	69	74	74	74	74	26	8000	10000
7	2.2	230	82	1.8	12.95	IE4	BM10-../S4E08MA4	11.5	38.5	77	230	275	58	69	82	82	82	24	8000	10000
7	2.2	230	82	1.8	12.95	IE5	BM10-../S5E08LA4	11.5	38.5	77	230	275	76	82	82	82	82	26	8000	10000
7	2.2	183	102	1.4	16.39	IE4	BM10-../S4E08MA4	9.1	30.5	61	183	215	72	86	102	102	102	24	8000	10000
7	2.2	183	102	1.4	16.39	IE5	BM10-../S5E08LA4	9.1	30.5	61	183	215	94	102	102	102	102	26	8000	10000
7	2.2	165	113	1.4	18.18	IE4	BM10-../S4E08MA4	8.2	27.5	55	165	198	80	95	113	113	113	24	8000	10000
7	2.2	165	113	1.4	18.18	IE5	BM10-../S5E08LA4	8.2	27.5	55	165	198	105	113	113	113	113	26	8000	10000
7	2.2	132	139	1.1	22.62	IE4	BM10-../S4E08MA4	6.6	22	44	132	159	99	117	139	139	139	24	8000	10000
7	2.2	132	139	1.1	22.62	IE5	BM10-../S5E08LA4	6.6	22	44	132	159	129	139	139	139	139	26	8000	10000
7	2.2	119	154	1	25.09	IE4	BM10-../S4E08MA4	5.9	19.5	39.5	119	143	110	130	154	154	154	24	8000	10000
7	2.2	119	154	1	25.09	IE5	BM10-../S5E08LA4	5.9	19.5	39.5	119	143	143	154	154	154	154	26	8000	10000
7	2.2	112	163	0.92	26.55	IE4	BM10-../S4E08MA4	5.6	18.5	37.5	112	135	116	137	163	163	163	24	8000	10000
7	2.2	112	163	0.92	26.55	IE5	BM10-../S5E08LA4	5.6	18.5	37.5	112	135	151	163	163	163	163	26	8000	10000
7	2.2	101	181	0.88	29.45	IE4	BM10-../S4E08MA4	5	16.5	33.5	101	122	129	152	181	181	181	24	8000	10000

# Geared motors for electric overhead conveyors series BM

## Selection table asynchronous motors PMSM IE4 3000 1/min

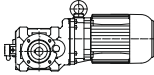
<b>MN = 7 Nm (PN = 2.2 kW)</b>																				
M <sub>N</sub>	P <sub>N</sub>	n <sub>2</sub>	M <sub>2</sub>	f <sub>B</sub>	i	IE- Class	Type	Speed range n <sub>2</sub> [1/min]					Torque range M <sub>2</sub> [Nm]					m	F <sub>RN</sub>	FRV
								at engine speed n <sub>1</sub> [1/min]					at engine speed n <sub>1</sub> [1/min]							
[Nm]	[kW]	[1/min]	[Nm]	[--]	[:1]			150	500	1000	3000	3600	150	500	1000	3000	3600	[kg]	[N]	[N]
7	2.2	101	181	0.88	29.45	IE5	BM10-../S5E08LA4	5	16.5	33.5	101	122	168	181	181	181	181	26	8000	10000
7	2.2	220	88	2.5	13.34	IE4	BM20-../S4E08MA4	11	37	74	220	265	63	74	88	88	88	26	12000	12000
7	2.2	220	88	2.5	13.34	IE5	BM20-../S5E08LA4	11	37	74	220	265	82	88	88	88	88	28	12000	12000
7	2.2	179	111	2	16.72	IE4	BM20-../S4E08MA4	8.9	29.5	59	179	215	79	93	111	111	111	26	12000	12000
7	2.2	179	111	2	16.72	IE5	BM20-../S5E08LA4	8.9	29.5	59	179	215	103	111	111	111	111	28	12000	12000
7	2.2	152	131	1.7	19.72	IE4	BM20-../S4E08MA4	7.6	25	50	152	182	93	110	131	131	131	26	12000	12000
7	2.2	152	131	1.7	19.72	IE5	BM20-../S5E08LA4	7.6	25	50	152	182	121	131	131	131	131	28	12000	12000
7	2.2	118	167	1.3	25.25	IE4	BM20-../S4E08MA4	5.9	19.5	39.5	118	142	119	141	167	167	167	26	12000	12000
7	2.2	118	167	1.3	25.25	IE5	BM20-../S5E08LA4	5.9	19.5	39.5	118	142	155	167	167	167	167	28	12000	12000
7	2.2	102	195	1.1	29.39	IE4	BM20-../S4E08MA4	5.1	17	34	102	122	139	164	195	195	195	26	12000	12000
7	2.2	102	195	1.1	29.39	IE5	BM20-../S5E08LA4	5.1	17	34	102	122	181	195	195	195	195	28	12000	12000
7	2.2	85	230	0.94	35.25	IE4	BM20-../S4E08MA4	4.2	14	28	85	102	167	197	230	230	230	26	12000	12000
7	2.2	85	230	0.94	35.25	IE5	BM20-../S5E08LA4	4.2	14	28	85	102	215	230	230	230	230	28	12000	12000
7	2.2	150	128	2.7	19.96	IE4	BM30-../S4E08MA4	7.5	25	50	150	180	91	108	128	128	128	42	12000	15000
7	2.2	150	128	2.7	19.96	IE5	BM30-../S5E08LA4	7.5	25	50	150	180	119	128	128	128	128	44	12000	15000
7	2.2	128	148	2.4	23.38	IE4	BM30-../S4E08MA4	6.4	21	42.5	128	153	106	125	148	148	148	42	12000	15000
7	2.2	128	148	2.4	23.38	IE5	BM30-../S5E08LA4	6.4	21	42.5	128	153	138	148	148	148	148	44	12000	15000
7	2.2	100	189	1.8	29.76	IE4	BM30-../S4E08MA4	5	16.5	33.5	100	120	135	159	189	189	189	42	12000	15000
7	2.2	100	189	1.8	29.76	IE5	BM30-../S5E08LA4	5	16.5	33.5	100	120	176	189	189	189	189	44	12000	15000
7	2.2	86	220	1.6	34.88	IE4	BM30-../S4E08MA4	4.3	14	28.5	86	103	158	187	220	220	220	42	12000	15000
7	2.2	86	220	1.6	34.88	IE5	BM30-../S5E08LA4	4.3	14	28.5	86	103	205	220	220	220	220	44	12000	15000
7	2.2	72	255	1.4	41.13	IE4	BM30-../S4E08MA4	3.6	12	24	72	87	185	215	255	255	255	42	12000	15000
7	2.2	72	255	1.4	41.13	IE5	BM30-../S5E08LA4	3.6	12	24	72	87	240	255	255	255	255	44	12000	15000
7	2.2	60	305	1	49.66	IE4	BM30-../S4E08MA4	3	10	20	60	72	220	260	305	305	305	42	12000	15000
7	2.2	60	305	1	49.66	IE5	BM30-../S5E08LA4	3	10	20	60	72	285	305	305	305	305	44	12000	15000
7	2.2	55	325	0.86	53.67	IE4	BM30Z../S4E08MA4	2.7	9.3	18.5	55	67	230	275	325	325	325	45	12000	15000
7	2.2	55	325	0.86	53.67	IE5	BM30Z../S5E08LA4	2.7	9.3	18.5	55	67	300	325	325	325	325	46	12000	15000
7	2.2	43	420	0.83	69.35	IE4	BM30Z../S4E08MA4	2.1	7.2	14	43	51	300	355	420	420	420	45	12000	15000
7	2.2	43	420	0.83	69.35	IE5	BM30Z../S5E08LA4	2.1	7.2	14	43	51	390	420	420	420	420	46	12000	15000
7	2.2	73	255	2.6	40.88	IE4	BM40-../S4E08MA4	3.6	12	24	73	88	183	215	255	255	255	63	20000	25000
7	2.2	73	255	2.6	40.88	IE5	BM40-../S5E08LA4	3.6	12	24	73	88	235	255	255	255	255	64	20000	25000
7	2.2	58	315	2.2	51.18	IE4	BM40-../S4E08MA4	2.9	9.7	19.5	58	70	225	265	315	315	315	63	20000	25000
7	2.2	58	315	2.2	51.18	IE5	BM40-../S5E08LA4	2.9	9.7	19.5	58	70	290	315	315	315	315	64	20000	25000
7	2.2	50	365	1.9	59.66	IE4	BM40-../S4E08MA4	2.5	8.3	16.5	50	60	260	305	365	365	365	63	20000	25000
7	2.2	50	365	1.9	59.66	IE5	BM40-../S5E08LA4	2.5	8.3	16.5	50	60	340	365	365	365	365	64	20000	25000
7	2.2	42.5	425	1.6	70.11	IE4	BM40-../S4E08MA4	2.1	7.1	14	42.5	51	300	355	425	425	425	63	20000	25000
7	2.2	42.5	425	1.6	70.11	IE5	BM40-../S5E08LA4	2.1	7.1	14	42.5	51	395	425	425	425	425	64	20000	25000
7	2.2	35.5	510	1.2	84.36	IE4	BM40-../S4E08MA4	1.7	5.9	11.5	35.5	42.5	365	430	510	510	510	63	20000	25000
7	2.2	35.5	510	1.2	84.36	IE5	BM40-../S5E08LA4	1.7	5.9	11.5	35.5	42.5	475	510	510	510	510	64	20000	25000
7	2.2	28.5	610	0.97	104	IE4	BM40-../S4E08MA4	1.4	4.8	9.6	28.5	34.5	440	520	610	610	610	63	20000	25000
7	2.2	28.5	610	0.97	104	IE5	BM40-../S5E08LA4	1.4	4.8	9.6	28.5	34.5	570	610	610	610	610	64	20000	25000
7	2.2	25	700	0.97	118.2	IE4	BM40Z../S4E08MA4	1.2	4.2	8.4	25	30	500	590	700	700	700	67	20000	25000
7	2.2	25	700	0.97	118.2	IE5	BM40Z../S5E08LA4	1.2	4.2	8.4	25	30	650	700	700	700	700	69	20000	25000
7	2.2	20.5	840	0.81	143	IE4	BM40Z../S4E08MA4	1	3.4	6.9	20.5	25	600	700	840	840	840	67	20000	25000
7	2.2	20.5	840	0.81	143	IE5	BM40Z../S5E08LA4	1	3.4	6.9	20.5	25	780	840	840	840	840	69	20000	25000

9

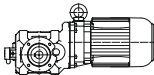
<b>MN = 10 Nm (PN = 3.1 kW)</b>																				
M <sub>N</sub>	P <sub>N</sub>	n <sub>2</sub>	M <sub>2</sub>	f <sub>B</sub>	i	IE- Class	Type	Speed range n <sub>2</sub> [1/min]					Torque range M <sub>2</sub> [Nm]					m	F <sub>RN</sub>	FRV
								at engine speed n <sub>1</sub> [1/min]					at engine speed n <sub>1</sub> [1/min]							
[Nm]	[kW]	[1/min]	[Nm]	[--]	[:1]			150	500	1000	3000	3600	150	500	1000	3000	3600	[kg]	[N]	[N]
10	3.1	255	106	1.3	11.68	IE3	BM10-../SPE08LA4	12.5	42.5	85	255	305	69	85	106	106	106	26	8000	10000
10	3.1	230	117	1.3	12.95	IE3	BM10-../SPE08LA4	11.5	38.5	77	230	275	76	94	117	117	117	26	8000	10000
10	3.1	183	145	0.99	16.39	IE3	BM10-../SPE08LA4	9.1	30.5	61	183	215	94	116	145	145	145	26	8000	10000
10	3.1	165	161	0.96	18.18	IE3	BM10-../SPE08LA4	8.2	27.5	55	165	198	105	129	161	161	161	26	8000	10000
10	3.1	390	72	2.7	7.66	IE3	BM20-../SPE08LA4	19.5	65	130	390	465	47	58	72	72	72	28	9100	10900
10	3.1	295	96	2.3	10.15	IE3	BM20-../SPE08LA4	14.5	49	98	295	350	62	77	96	96	96	28	12000	12000
10	3.1	220	126	1.7	13.34	IE3	BM20-../SPE08LA4	11	37	74	220	265	82	101	126	126	126	28	12000	12000
10	3.1	179	158	1.4	16.72	IE3	BM20-../SPE08LA4	8.9	29.5	59	179	215	103	127	158	158	158	28	12000	12000
10	3.1	152	187	1.2	19.72	IE3	BM20-../SPE08LA4	7.6	25	50	152	182	121	149	187	187	187	28	12000	12000
10	3.1	118	235	0.92	25.25	IE3	BM20-../SPE08LA4	5.9	19.5	39.5	118	142	155	191	235	235	235	28	12000	12000
10	3.1	186	148	2.4	16.1	IE3	BM30-../SPE08LA4	9.3	31	62	186	220	96	118	148	148	148	44	12000	15000
10	3.1	150	183	1.9	19.96	IE3	BM30-../SPE08LA4	7.5	25	50	150	180	119	146	183	183	183	44	12000	15000
10	3.1	128	210	1.6	23.38	IE3	BM30-../SPE08LA4	6.4	21	42.5	128	153	138	170	210	210	210	44	12000	15000
10	3.1	100	270	1.3	29.76	IE3	BM30-../SPE08LA4	5	16.5	33.5	100	120	176	215	270	270	270	44	12000	15000
10	3.1	86	315	1.1	34.88	IE3	BM30-../SPE08LA4	4.3	14	28.5	86	103	205	250	315	315	315	44	12000	15000
10	3.1	72	370	0.95	41.13	IE3	BM30-../SPE08LA4	3.6	12	24	72	87	240	295	370	370	370	44	12000	15000
10	3.1	104	255	2.6	28.59	IE3	BM40-../SPE08LA4	5.2	17	34.5	104	125	167	205	255	255	255	64	20000	25000
10	3.1	86	310	2.2	34.61	IE3</														

# Geared motors for electric overhead conveyors series BM

## Selection table asynchronous motors PMSM IE4 3000 1/min

### MN = 10 Nm (PN = 3.1 kW)

IE4

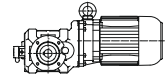

M <sub>N</sub> [Nm]	P <sub>N</sub> [kW]	n <sub>2</sub> [1/min]	M <sub>2</sub> [Nm]	f <sub>B</sub> [-]	i [:1]	IE- Classe	Type	Speed range n <sub>2</sub> [1/min]					Torque range M <sub>2</sub> [Nm]					m [kg]	F <sub>RN</sub> [N]	FRV [N]
								at engine speed n <sub>1</sub> [1/min]					at engine speed n <sub>1</sub> [1/min]							
								150	500	1000	3000	3600	150	500	1000	3000	3600			
10	3.1	50	520	1.3	59.66	IE3	BM40-../SPE08LA4	2.5	8.3	16.5	50	60	340	420	520	520	520	64	20000	25000
10	3.1	42.5	600	1.1	70.11	IE3	BM40-../SPE08LA4	2.1	7.1	14	42.5	51	395	485	600	600	600	64	20000	25000
10	3.1	35.5	730	0.82	84.36	IE3	BM40-../SPE08LA4	1.7	5.9	11.5	35.5	42.5	475	580	730	730	730	64	20000	25000

### MN = 13 Nm (PN = 4 kW)

IE4

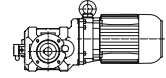

M <sub>N</sub> [Nm]	P <sub>N</sub> [kW]	n <sub>2</sub> [1/min]	M <sub>2</sub> [Nm]	f <sub>B</sub> [-]	i [:1]	IE- Classe	Type	Speed range n <sub>2</sub> [1/min]					Torque range M <sub>2</sub> [Nm]					m [kg]	F <sub>RN</sub> [N]	FRV [N]
								at engine speed n <sub>1</sub> [1/min]					at engine speed n <sub>1</sub> [1/min]							
								150	500	1000	3000	3600	150	500	1000	3000	3600			
13	4	255	138	1	11.68	IE4	BM10-../S4E09SA4	12.5	42.5	85	255	305	90	106	138	138	138	30	8000	10000
13	4	230	153	0.98	12.95	IE4	BM10-../S4E09SA4	11.5	38.5	77	230	275	100	117	153	153	153	30	8000	10000
13	4	390	94	2.1	7.66	IE4	BM20-../S4E09SA4	19.5	65	130	390	465	61	72	94	94	94	32	9100	10900
13	4	295	125	1.8	10.15	IE4	BM20-../S4E09SA4	14.5	49	98	295	350	81	96	125	125	125	32	12000	12000
13	4	220	164	1.3	13.34	IE4	BM20-../S4E09SA4	11	37	74	220	265	107	126	164	164	164	32	12000	12000
13	4	179	205	1.1	16.72	IE4	BM20-../S4E09SA4	8.9	29.5	59	179	215	135	158	205	205	205	32	12000	12000
13	4	152	240	0.9	19.72	IE4	BM20-../S4E09SA4	7.6	25	50	152	182	159	187	240	240	240	32	12000	12000
13	4	295	120	2.9	10.06	IE4	BM30-../S4E09SA4	14.5	49.5	99	295	355	78	92	120	120	120	48	12000	15000
13	4	240	149	2.3	12.46	IE4	BM30-../S4E09SA4	12	40	80	240	285	97	114	149	149	149	48	12000	15000
13	4	186	192	1.8	16.1	IE4	BM30-../S4E09SA4	9.3	31	62	186	220	125	148	192	192	192	48	12000	15000
13	4	150	235	1.5	19.96	IE4	BM30-../S4E09SA4	7.5	25	50	150	180	156	183	235	235	235	48	12000	15000
13	4	128	275	1.3	23.38	IE4	BM30-../S4E09SA4	6.4	21	42.5	128	153	180	210	275	275	275	48	12000	15000
13	4	100	350	0.99	29.76	IE4	BM30-../S4E09SA4	5	16.5	33.5	100	120	230	270	350	350	350	48	12000	15000
13	4	86	410	0.85	34.88	IE4	BM30-../S4E09SA4	4.3	14	28.5	86	103	265	315	410	410	410	48	12000	15000
13	4	133	260	2.6	22.44	IE4	BM40-../S4E09SA4	6.6	22	44.5	133	160	171	200	260	260	260	68	20000	25000
13	4	104	330	2	28.59	IE4	BM40-../S4E09SA4	5.2	17	34.5	104	125	215	255	330	330	330	68	20000	25000
13	4	86	400	1.7	34.61	IE4	BM40-../S4E09SA4	4.3	14	28.5	86	104	260	310	400	400	400	68	20000	25000
13	4	73	475	1.4	40.88	IE4	BM40-../S4E09SA4	3.6	12	24	73	88	310	365	475	475	475	68	20000	25000
13	4	58	580	1.2	51.18	IE4	BM40-../S4E09SA4	2.9	9.7	19.5	58	70	380	450	580	580	580	68	20000	25000
13	4	50	680	1	59.66	IE4	BM40-../S4E09SA4	2.5	8.3	16.5	50	60	445	520	680	680	680	68	20000	25000
13	4	42.5	790	0.86	70.11	IE4	BM40-../S4E09SA4	2.1	7.1	14	42.5	51	510	600	790	790	790	68	20000	25000

### MN = 17.5 Nm (PN = 5.5 kW)

IE4

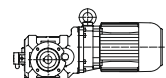

M <sub>N</sub> [Nm]	P <sub>N</sub> [kW]	n <sub>2</sub> [1/min]	M <sub>2</sub> [Nm]	f <sub>B</sub> [-]	i [:1]	IE- Classe	Type	Speed range n <sub>2</sub> [1/min]					Torque range M <sub>2</sub> [Nm]					m [kg]	F <sub>RN</sub> [N]	FRV [N]
								at engine speed n <sub>1</sub> [1/min]					at engine speed n <sub>1</sub> [1/min]							
								150	500	1000	3000	3600	150	500	1000	3000	3600			
17.5	5.5	390	127	1.6	7.66	IE5	BM20-../S5E09XA4	19.5	65	130	390	465	94	116	127	127	127	40	9100	10900
17.5	5.5	295	168	1.3	10.15	IE5	BM20-../S5E09XA4	14.5	49	98	295	350	125	154	168	168	168	40	12000	12000
17.5	5.5	220	220	0.99	13.34	IE5	BM20-../S5E09XA4	11	37	74	220	265	164	200	220	220	220	40	12000	12000
17.5	5.5	375	127	2.5	7.91	IE4	BM30-../S4E11SA6	18.5	63	126	375	455	127	127	127	127	127	65	11000	13800
17.5	5.5	375	127	2.5	7.91	IE5	BM30-../S5E09XA4	18.5	63	126	375	455	94	116	127	127	127	56	11000	13800
17.5	5.5	295	161	2.2	10.06	IE4	BM30-../S4E11SA6	14.5	49.5	99	295	355	161	161	161	161	161	65	12000	15000
17.5	5.5	295	161	2.2	10.06	IE5	BM30-../S5E09XA4	14.5	49.5	99	295	355	120	148	161	161	161	56	12000	15000
17.5	5.5	240	200	1.7	12.46	IE4	BM30-../S4E11SA6	12	40	80	240	285	200	200	200	200	200	65	12000	15000
17.5	5.5	240	200	1.7	12.46	IE5	BM30-../S5E09XA4	12	40	80	240	285	149	183	200	200	200	56	12000	15000
17.5	5.5	186	255	1.4	16.1	IE4	BM30-../S4E11SA6	9.3	31	62	186	220	255	255	255	255	255	65	12000	15000
17.5	5.5	186	255	1.4	16.1	IE5	BM30-../S5E09XA4	9.3	31	62	186	220	192	235	255	255	255	56	12000	15000
17.5	5.5	150	320	1.1	19.96	IE4	BM30-../S4E11SA6	7.5	25	50	150	180	320	320	320	320	320	65	12000	15000
17.5	5.5	150	320	1.1	19.96	IE5	BM30-../S5E09XA4	7.5	25	50	150	180	235	290	320	320	320	56	12000	15000
17.5	5.5	128	370	0.94	23.38	IE4	BM30-../S4E11SA6	6.4	21	42.5	128	153	370	370	370	370	370	65	12000	15000
17.5	5.5	128	370	0.94	23.38	IE5	BM30-../S5E09XA4	6.4	21	42.5	128	153	275	340	370	370	370	56	12000	15000
17.5	5.5	205	225	3	14.5	IE4	BM40-../S4E11SA6	10	34	68	205	245	225	225	225	225	225	90	20000	25000
17.5	5.5	205	225	3	14.5	IE5	BM40-../S5E09XA4	10	34	68	205	245	169	205	225	225	225	76	20000	25000
17.5	5.5	166	280	2.4	18.05	IE4	BM40-../S4E11SA6	8.3	27.5	55	166	199	280	280	280	280	280	90	20000	25000
17.5	5.5	166	280	2.4	18.05	IE5	BM40-../S5E09XA4	8.3	27.5	55	166	199	210	255	280	280	280	76	20000	25000
17.5	5.5	133	350	1.9	22.44	IE4	BM40-../S4E11SA6	6.6	22	44.5	133	160	350	350	350	350	350	90	20000	25000
17.5	5.5	133	350	1.9	22.44	IE5	BM40-../S5E09XA4	6.6	22	44.5	133	160	260	320	350	350	350	76	20000	25000
17.5	5.5	104	450	1.5	28.59	IE4	BM40-../S4E11SA6	5.2	17	34.5	104	125	450	450	450	450	450	90	20000	25000
17.5	5.5	104	450	1.5	28.59	IE5	BM40-../S5E09XA4	5.2	17	34.5	104	125	330	410	450	450	450	76	20000	25000
17.5	5.5	86	540	1.2	34.61	IE4	BM40-../S4E11SA6	4.3	14	28.5	86	104	540	540	540	540	540	90	20000	25000
17.5	5.5	86	540	1.2	34.61	IE5	BM40-../S5E09XA4	4.3	14	28.5	86	104	400	495	540	540	540	76	20000	25000
17.5	5.5	73	640	1.1	40.88	IE4	BM40-../S4E11SA6	3.6	12	24	73	88	640	640	640	640	640	90	20000	25000
17.5	5.5	73	640	1.1	40.88	IE5	BM40-../S5E09XA4	3.6	12	24	73	88	475	580	640	640	640	76	20000	25000



# Geared motors for electric overhead conveyors series BM

## Selection table asynchronous motors PMSM IE4 3000 1/ min

### MN = 20 Nm (PN = 6.3 kW)

IE4

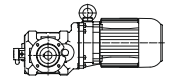

M <sub>N</sub> [Nm]	P <sub>N</sub> [kW]	n <sub>2</sub> [1/min]	M <sub>2</sub> [Nm]	f <sub>B</sub> [--]	i [:1]	IE- Classe	Type	Speed range n <sub>2</sub> [1/min] at engine speed n <sub>1</sub> [1/min]					Torque range M <sub>2</sub> [Nm] at engine speed n <sub>1</sub> [1/min]					m [kg]	F <sub>RN</sub> [N]	FRV [N]
								150	500	1000	3000	3600	150	500	1000	3000	3600			
								20	6.3	390	145	1.4	7.66	IE5	BM20-../S5E09XA4	19.5	65			
20	6.3	295	192	1.1	10.15	IE5	BM20-../S5E09XA4	14.5	49	98	295	350	125	154	192	192	168	40	12000	12000
20	6.3	220	250	0.87	13.34	IE5	BM20-../S5E09XA4	11	37	74	220	265	164	200	250	250	220	40	12000	12000
20	6.3	375	145	2.2	7.91	IE5	BM30-../S5E09XA4	18.5	63	126	375	455	94	116	145	145	127	56	11000	13800
20	6.3	295	185	1.9	10.06	IE5	BM30-../S5E09XA4	14.5	49.5	99	295	355	120	148	185	185	161	56	12000	15000
20	6.3	240	225	1.5	12.46	IE5	BM30-../S5E09XA4	12	40	80	240	285	149	183	225	225	200	56	12000	15000
20	6.3	186	295	1.2	16.1	IE5	BM30-../S5E09XA4	9.3	31	62	186	220	192	235	295	295	255	56	12000	15000
20	6.3	150	365	0.95	19.96	IE5	BM30-../S5E09XA4	7.5	25	50	150	180	235	290	365	365	320	56	12000	15000
20	6.3	128	425	0.82	23.38	IE5	BM30-../S5E09XA4	6.4	21	42.5	128	153	275	340	425	425	370	56	12000	15000
20	6.3	205	260	2.6	14.5	IE5	BM40-../S5E09XA4	10	34	68	205	245	169	205	260	260	225	76	20000	25000
20	6.3	166	320	2.1	18.05	IE5	BM40-../S5E09XA4	8.3	27.5	55	166	199	210	255	320	320	280	76	20000	25000
20	6.3	133	400	1.7	22.44	IE5	BM40-../S5E09XA4	6.6	22	44.5	133	160	260	320	400	400	350	76	20000	25000
20	6.3	104	510	1.3	28.59	IE5	BM40-../S5E09XA4	5.2	17	34.5	104	125	330	410	510	510	450	76	20000	25000
20	6.3	86	620	1.1	34.61	IE5	BM40-../S5E09XA4	4.3	14	28.5	86	104	400	495	620	620	540	76	20000	25000
20	6.3	73	730	0.92	40.88	IE5	BM40-../S5E09XA4	3.6	12	24	73	88	475	580	730	730	640	76	20000	25000

### MN = 24 Nm (PN = 7.5 kW)

IE4

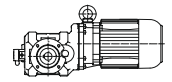

M <sub>N</sub> [Nm]	P <sub>N</sub> [kW]	n <sub>2</sub> [1/min]	M <sub>2</sub> [Nm]	f <sub>B</sub> [--]	i [:1]	IE- Classe	Type	Speed range n <sub>2</sub> [1/min] at engine speed n <sub>1</sub> [1/min]					Torque range M <sub>2</sub> [Nm] at engine speed n <sub>1</sub> [1/min]					m [kg]	F <sub>RN</sub> [N]	FRV [N]
								150	500	1000	3000	3600	150	500	1000	3000	3600			
								24	7.5	375	174	1.8	7.91	IE4	BM30-../S4E11SA6	18.5	63			
24	7.5	295	174	1.8	7.91	IE5	BM30-../S5E11MA6	18.5	63	126	375	455	174	174	174	174	174	65	11000	13800
24	7.5	220	220	1.6	10.06	IE4	BM30-../S4E11SA6	14.5	49.5	99	220	265	175	198	220	220	220	65	12000	15000
24	7.5	295	220	1.6	10.06	IE5	BM30-../S5E11MA6	14.5	49.5	99	220	265	220	220	220	220	220	65	12000	15000
24	7.5	240	275	1.3	12.46	IE4	BM30-../S4E11SA6	12	40	80	240	285	215	245	275	275	275	65	12000	15000
24	7.5	240	275	1.3	12.46	IE5	BM30-../S5E11MA6	12	40	80	240	285	275	275	275	275	275	65	12000	15000
24	7.5	186	355	0.98	16.1	IE4	BM30-../S4E11SA6	9.3	31	62	186	220	280	315	355	355	355	65	12000	15000
24	7.5	186	355	0.98	16.1	IE5	BM30-../S5E11MA6	9.3	31	62	186	220	355	355	355	355	355	65	12000	15000
24	7.5	265	240	2.6	11.17	IE4	BM40-../S4E11SA6	13	44.5	89	265	320	191	215	240	240	240	90	18300	22900
24	7.5	265	240	2.6	11.17	IE5	BM40-../S5E11MA6	13	44.5	89	265	320	240	240	240	240	240	90	18300	22900
24	7.5	205	310	2.2	14.5	IE4	BM40-../S4E11SA6	10	34	68	205	245	245	280	310	310	310	90	20000	25000
24	7.5	205	310	2.2	14.5	IE5	BM40-../S5E11MA6	10	34	68	205	245	310	310	310	310	310	90	20000	25000
24	7.5	166	385	1.7	18.05	IE4	BM40-../S4E11SA6	8.3	27.5	55	166	199	305	345	385	385	385	90	20000	25000
24	7.5	166	385	1.7	18.05	IE5	BM40-../S5E11MA6	8.3	27.5	55	166	199	385	385	385	385	385	90	20000	25000
24	7.5	133	480	1.4	22.44	IE4	BM40-../S4E11SA6	6.6	22	44.5	133	160	380	430	480	480	480	90	20000	25000
24	7.5	133	480	1.4	22.44	IE5	BM40-../S5E11MA6	6.6	22	44.5	133	160	480	480	480	480	480	90	20000	25000
24	7.5	104	610	1.1	28.59	IE4	BM40-../S4E11SA6	5.2	17	34.5	104	125	485	550	610	610	610	90	20000	25000
24	7.5	104	610	1.1	28.59	IE5	BM40-../S5E11MA6	5.2	17	34.5	104	125	610	610	610	610	610	90	20000	25000
24	7.5	86	740	0.91	34.61	IE4	BM40-../S4E11SA6	4.3	14	28.5	86	104	590	660	740	740	740	90	20000	25000
24	7.5	86	740	0.91	34.61	IE5	BM40-../S5E11MA6	4.3	14	28.5	86	104	740	740	740	740	740	90	20000	25000

### MN = 30 Nm (PN = 9.5 kW)

IE4

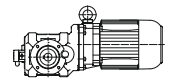

M <sub>N</sub> [Nm]	P <sub>N</sub> [kW]	n <sub>2</sub> [1/min]	M <sub>2</sub> [Nm]	f <sub>B</sub> [--]	i [:1]	IE- Classe	Type	Speed range n <sub>2</sub> [1/min] at engine speed n <sub>1</sub> [1/min]					Torque range M <sub>2</sub> [Nm] at engine speed n <sub>1</sub> [1/min]					m [kg]	F <sub>RN</sub> [N]	FRV [N]
								150	500	1000	3000	3600	150	500	1000	3000	3600			
								30	9.5	375	215	1.5	7.91	IE5	BM30-../S5E11LA6	18.5	63			
30	9.5	375	215	1.5	7.91	IE5	BM30-../S5E11MA6	18.5	63	126	375	455	192	215	215	215	215	65	11000	13800
30	9.5	295	275	1.3	10.06	IE5	BM30-../S5E11LA6	14.5	49.5	99	295	355	275	275	275	275	275	76	12000	15000
30	9.5	295	275	1.3	10.06	IE5	BM30-../S5E11MA6	14.5	49.5	99	295	355	245	275	275	275	275	65	12000	15000
30	9.5	240	340	1	12.46	IE5	BM30-../S5E11LA6	12	40	80	240	285	340	340	340	340	340	76	12000	15000
30	9.5	240	340	1	12.46	IE5	BM30-../S5E11MA6	12	40	80	240	285	300	340	340	340	340	65	12000	15000
30	9.5	265	300	2.1	11.17	IE5	BM40-../S5E11LA6	13	44.5	89	265	320	300	300	300	300	300	102	18300	22900
30	9.5	265	300	2.1	11.17	IE5	BM40-../S5E11MA6	13	44.5	89	265	320	265	300	300	300	300	90	18300	22900
30	9.5	205	390	1.7	14.5	IE5	BM40-../S5E11LA6	10	34	68	205	245	390	390	390	390	390	102	20000	25000
30	9.5	205	390	1.7	14.5	IE5	BM40-../S5E11MA6	10	34	68	205	245	345	390	390	390	390	90	20000	25000
30	9.5	166	485	1.4	18.05	IE5	BM40-../S5E11LA6	8.3	27.5	55	166	199	485	485	485	485	485	102	20000	25000
30	9.5	166	485	1.4	18.05	IE5	BM40-../S5E11MA6	8.3	27.5	55	166	199	430	485	485	485	485	90	20000	25000
30	9.5	133	600	1.1	22.44	IE5	BM40-../S5E11LA6	6.6	22	44.5	133	160	600	600	600	600	600	102	20000	25000
30	9.5	133	600	1.1	22.44	IE5	BM40-../S5E11MA6	6.6	22	44.5	133	160	530	600	600	600	600	90	20000	25000
30	9.5	104	770	0.88	28.59	IE5	BM40-../S5E11LA6	5.2	17	34.5	104	125	770	770	770	770	770	102	20000	25000
30	9.5	104	770	0.88	28.59	IE5	BM40-../S5E11MA6	5.2	17	34.5	104	125	680	770	770	770	770	90	20000	25000

# Geared motors for electric overhead conveyors series BM

## Selection table asynchronous motors PMSM IE4 3000 1/min

### MN = 35 Nm (PN = 11 kW)

IE4

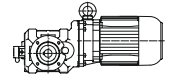

M <sub>N</sub> [Nm]	P <sub>N</sub> [kW]	n <sub>2</sub> [1/min]	M <sub>2</sub> [Nm]	f <sub>B</sub> [-]	i [:1]	IE- Classe	Type	Speed range n <sub>2</sub> [1/min] at engine speed n <sub>1</sub> [1/min]					Torque range M <sub>2</sub> [Nm] at engine speed n <sub>1</sub> [1/min]					m [kg]	F <sub>RN</sub> [N]	F <sub>RV</sub> [N]
								150	500	1000	3000	3600	150	500	1000	3000	3600			
35	11	375	250	1.3	7.91	IE4	BM30-../S4E11MA6	18.5	63	126	375	455	192	215	250	250	250	65	11000	13800
35	11	375	250	1.3	7.91	IE5	BM30-../S5E11LA6	18.5	63	126	375	455	250	250	250	250	250	76	11000	13800
35	11	295	320	1.1	10.06	IE4	BM30-../S4E11MA6	14.5	49.5	99	295	355	245	275	320	320	320	65	12000	15000
35	11	295	320	1.1	10.06	IE5	BM30-../S5E11LA6	14.5	49.5	99	295	355	320	320	320	320	320	76	12000	15000
35	11	240	400	0.87	12.46	IE4	BM30-../S4E11MA6	12	40	80	240	285	300	340	400	400	400	65	12000	15000
35	11	240	400	0.87	12.46	IE5	BM30-../S5E11LA6	12	40	80	240	285	400	400	400	400	400	76	12000	15000
35	11	265	350	1.8	11.17	IE4	BM40-../S4E11MA6	13	44.5	89	265	320	265	300	350	350	350	90	18300	22900
35	11	265	350	1.8	11.17	IE5	BM40-../S5E11LA6	13	44.5	89	265	320	350	350	350	350	350	102	18300	22900
35	11	205	455	1.5	14.5	IE4	BM40-../S4E11MA6	10	34	68	205	245	345	390	455	455	455	90	20000	25000
35	11	205	455	1.5	14.5	IE5	BM40-../S5E11LA6	10	34	68	205	245	455	455	455	455	455	102	20000	25000
35	11	166	560	1.2	18.05	IE4	BM40-../S4E11MA6	8.3	27.5	55	166	199	430	485	560	560	560	90	20000	25000
35	11	166	560	1.2	18.05	IE5	BM40-../S5E11LA6	8.3	27.5	55	166	199	560	560	560	560	560	102	20000	25000
35	11	133	700	0.96	22.44	IE4	BM40-../S4E11MA6	6.6	22	44.5	133	160	530	600	700	700	700	90	20000	25000
35	11	133	700	0.96	22.44	IE5	BM40-../S5E11LA6	6.6	22	44.5	133	160	700	700	700	700	700	102	20000	25000

### MN = 48 Nm (PN = 15 kW)

IE4

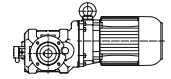

M <sub>N</sub> [Nm]	P <sub>N</sub> [kW]	n <sub>2</sub> [1/min]	M <sub>2</sub> [Nm]	f <sub>B</sub> [-]	i [:1]	IE- Classe	Type	Speed range n <sub>2</sub> [1/min] at engine speed n <sub>1</sub> [1/min]					Torque range M <sub>2</sub> [Nm] at engine speed n <sub>1</sub> [1/min]					m [kg]	F <sub>RN</sub> [N]	F <sub>RV</sub> [N]
								150	500	1000	3000	3600	150	500	1000	3000	3600			
48	15	375	345	0.92	7.91	IE5	BM30-../S5E11LA6	18.5	63	126	375	455	250	290	345	345	290	76	11000	13800
48	15	265	480	1.3	11.17	IE5	BM40-../S5E11LA6	13	44.5	89	265	320	350	400	480	480	400	102	18300	22900
48	15	205	620	1.1	14.5	IE5	BM40-../S5E11LA6	10	34	68	205	245	455	520	620	620	520	102	20000	25000
48	15	166	770	0.87	18.05	IE5	BM40-../S5E11LA6	8.3	27.5	55	166	199	560	640	770	770	640	102	20000	25000

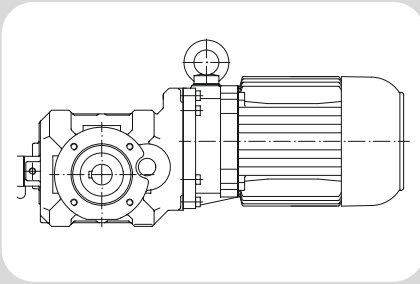

# 10

### Electric overhead conveyors series BM - Dimension

<b>Dimension - Standard .....</b>	<b>113</b>
BM09.....	113
BM10-BM10X.....	114
BM20-BM20Z.....	116
BM30-BM30Z.....	118
BM40-BM40Z.....	120
<b>Additional Dimension Sheet .....</b>	<b>122</b>
Standard terminal box.....	122
Plug-connector terminal box.....	123
Standard brakes.....	124
“Heavy-Duty“- brake.....	125
Motors with back stop.....	126
Motors with second shaft end.....	127
Motors with brake and second shaft end.....	128
Motors with “heavy duty“ brake and second shaft end.....	129
Motors with protective hood.....	130
Motors with independent fan.....	131
Motors with brake and independent fan.....	132
Motors with encoder and built-on independent fan.....	133
Motors with brake and encoder with built-on independent fan.....	134
Motors with standard encoder.....	135
Motors with “heavy duty“ encoder.....	136
Motors with brake and encoder.....	137
Motors with “heavy duty“ brake and encoder.....	138
Motors in IEC design.....	139

# Energy Efficient Geared Motors

## Electric overhead conveyors series BM

---

# Electric overhead conveyors series BM

## Dimension - Standard

### BM09

Flange with tapped holes at front. Follow-up type of SZ2-V3209

Code -7.V/

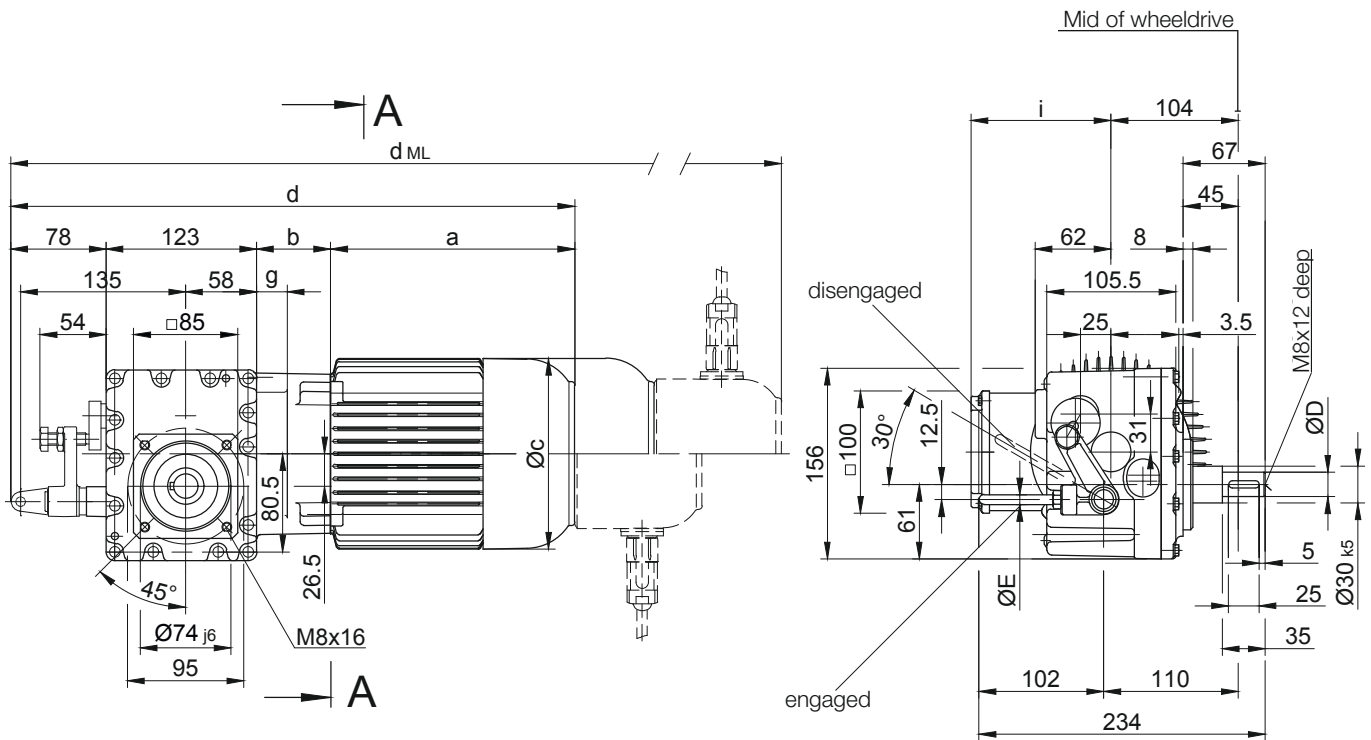

Code -7.V/

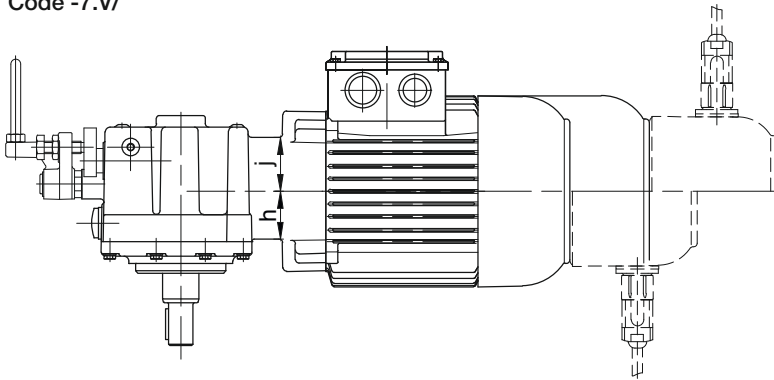

Code -1/

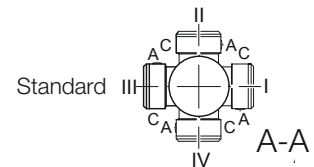
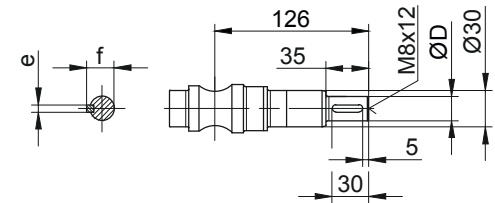

Type	a	b	c	d	i	Design with motor extensions				
						i <sub>TB</sub>	Brake	Encoder	Brake with Encoder	Back Stop
							d <sub>ML</sub>	d <sub>ML</sub>	d <sub>ML</sub>	d <sub>ML</sub>
BM09(X)-../D..05.A.	170.5	30	123	401.5	101	117	443.5	504	541.5	-
BM09(X)-../D..06.A.	170.5	30	123	401.5	99	119	443.5	504	541.5	-
BM09(X)-../S..06.A.	170.5	30	123	401.5	99	119	443.5	504	541.5	-
BM09(X)-../D..07.A.	190.5	30	123	421.5	99	119	463.5	524	561.5	-
BM09(X)-../D..08.A.	199.5	74	156	474.5	114.5	136.5	540.5	586.5	648	-
BM09(X)-../D..08.B.	199.5	74	156	474.5	114.5	136.5	275	616.5	677.5	-
BM09(X)-../S..08.A.	199.5	74	156	474.5	114.5	136.5	540.5	586.5	648	-
BM09(X)-../S..08.B.	199.5	74	156	474.5	114.5	136.5	275	616.5	677.5	-

Dimensions in millimetres (mm)

The actual gearbox design can vary from the geometry shown. Generate drive specific 3D and 2D geometries under [www.BauerCat.com](http://www.BauerCat.com).

# Electric overhead conveyors series BM

## Dimension - Standard

### BM10-BM10X

Flange with tapped holes at front

Code -7.V/

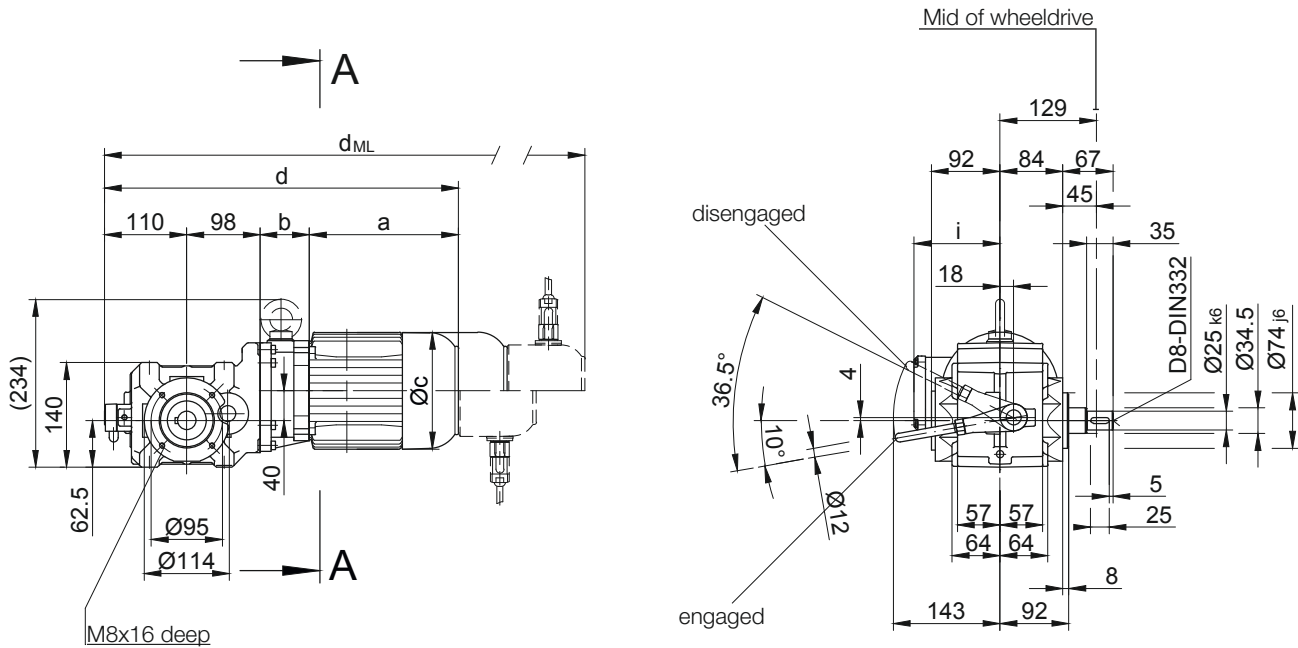

### Code -1/

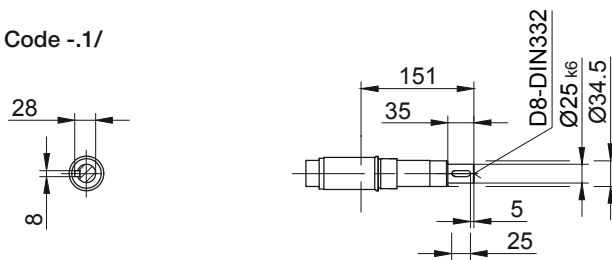

### Code -3/

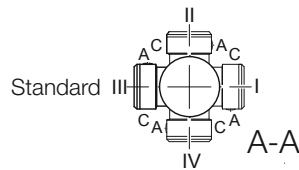
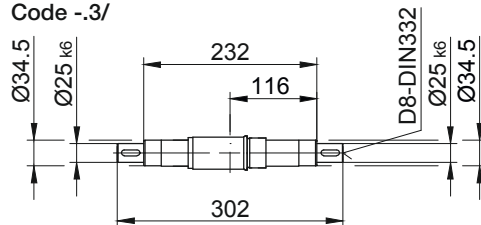

Type	a	b	c	d	i	Design with motor extensions				
						i <sub>TB</sub>	Brake	Encoder	Brake with Encoder	Back Stop
							d <sub>ML</sub>	d <sub>ML</sub>	d <sub>ML</sub>	d <sub>ML</sub>
BM10(X)-../D..05.A.	170.5	62	123	440.5	101	117	482.5	543	580.5	-
BM10(X)-../D..06.A.	170.5	62	123	440.5	99	119	482.5	543	580.5	-
BM10(X)-../S..06.A.	170.5	62	123	440.5	99	119	482.5	543	580.5	-
BM10(X)-../D..07.A.	190.5	62	123	460.5	99	119	502.5	563	600.5	-
BM10(X)-../D..08.A.	199.5	66	156	473.5	114.5	136.5	539.5	585.5	647	-
BM10(X)-../D..08.B.	229.5	66	156	503.5	114.5	136.5	569.5	615.5	676.5	-
BM10(X)-../S..08.A.	199.5	66	156	473.5	114.5	136.5	539.5	585.5	647	-
BM10(X)-../S..08.B.	229.5	66	156	503.5	114.5	136.5	569.5	615.5	676.5	-
BM10(X)-../D..09.A.	250.5	80.5	176	539	124	157	632	646.5	736	-
BM10(X)-../S..09.A.	250.5	80.5	176	539	124	157	632	646.5	736	-
BM10(X)-../D..09.B.	308.5	80.5	176	597	124	157	690	704	794	-
BM10(X)-../S..09.B.	308.5	80.5	176	597	124	157	690	704	794	-

Dimensions in millimetres (mm)

The actual gearbox design can vary from the geometry shown. Generate drive specific 3D and 2D geometries under [www.BauerCat.com](http://www.BauerCat.com).

### BM10-BM10X

Foot with tapped holes at bottom and top

Code -6.UO/

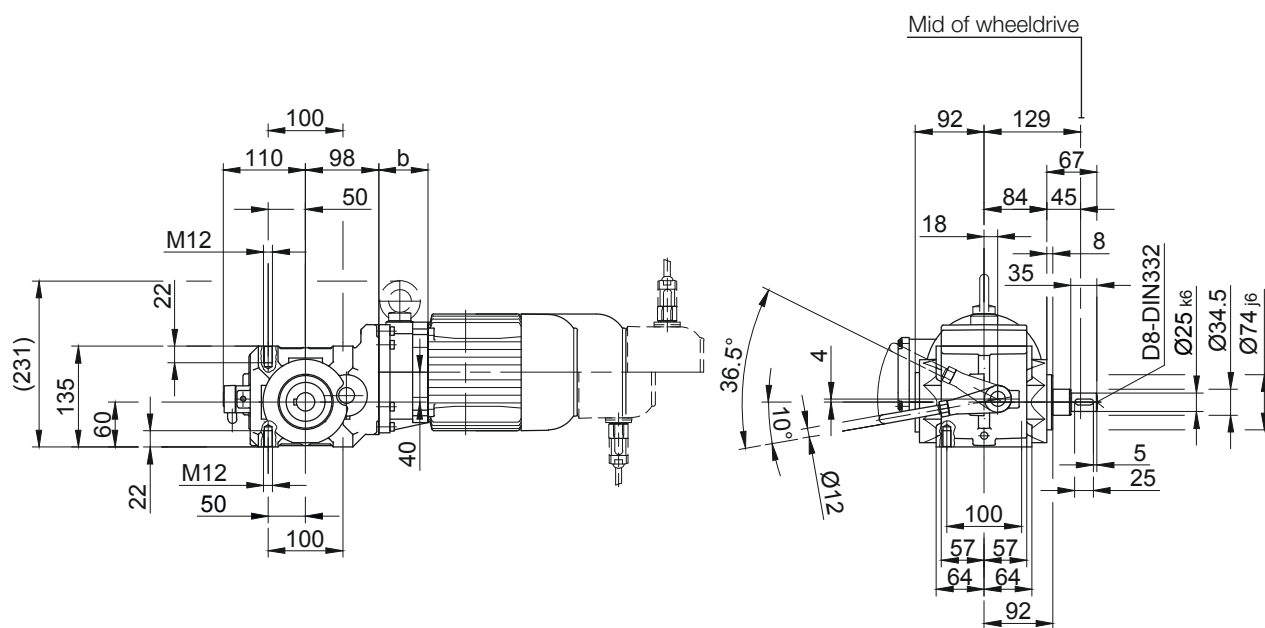

Code -3/

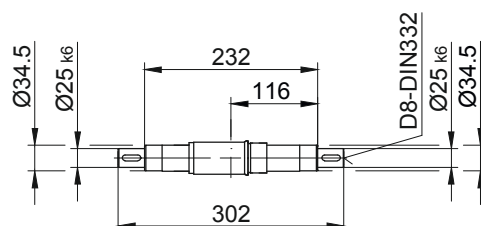

# Electric overhead conveyors series BM

## Dimension - Standard

### BM20-BM20Z

Flange with tapped holes at front

Code -7.V/

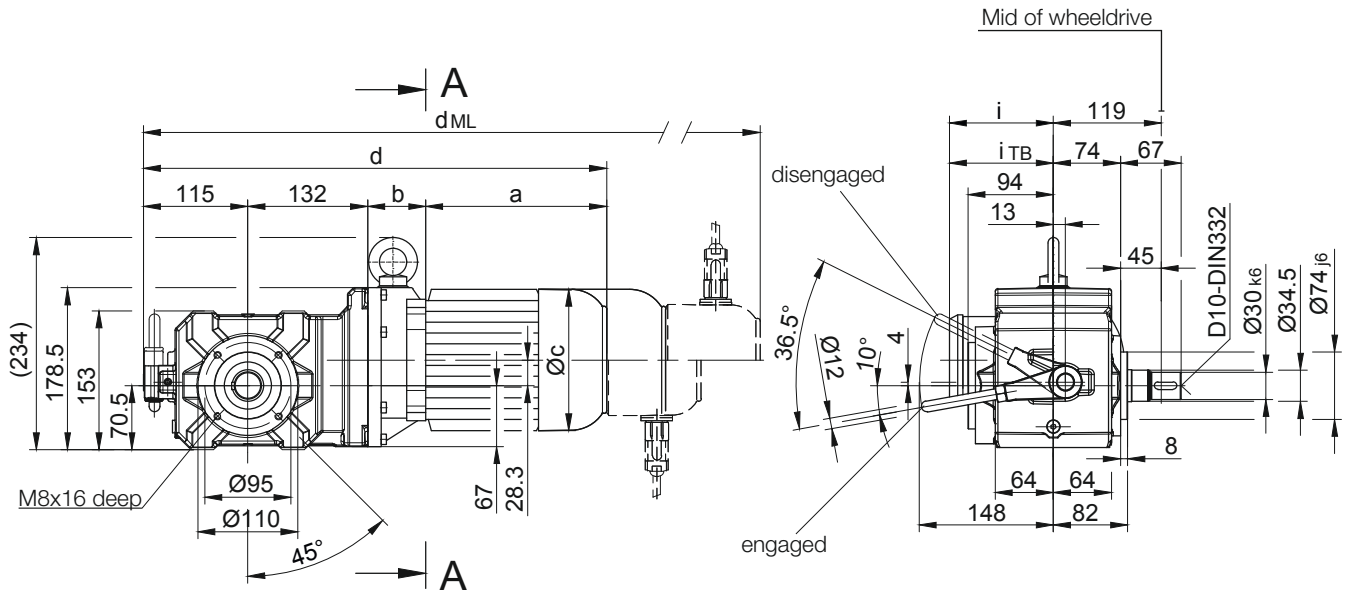

Code -1/

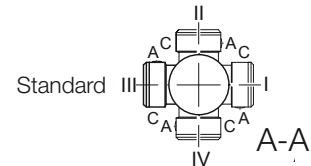
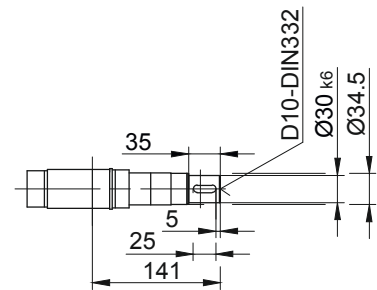
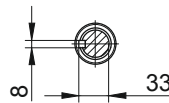

Type	a	b	c	d	i	Design with motor extensions				
						i <sub>TB</sub>	Brake	Encoder	Brake with Encoder	Back Stop
							d <sub>ML</sub>	d <sub>ML</sub>	d <sub>ML</sub>	d <sub>ML</sub>
BK20Z-.1/D04.A.	142.5	100	110.5	489.5	90	112	533	577	620.5	-
BK20Z-.1/S04.A.	142.5	100	110.5	489.5	90	112	533	577	620.5	-
BM20-.1/D..05.A.	170.5	60	123	477.5	101	117	519.5	580	617.5	-
BM20Z-.1/D..05.A.	170.5	102	123	519.5	101	117	561.5	622	659.5	-
BM20-.1/D..06.A.	170.5	60	123	477.5	99	119	519.5	580	617.5	-
BM20-.1/D..06.A.	170.5	102	123	519.5	99	119	561.5	622	659.5	-
BM20-.1/S..06.A.	170.5	60	123	477.5	99	119	519.5	580	617.5	-
BM20-.1/S..06.A.	170.5	102	123	519.5	99	119	561.5	622	659.5	-
BM20-.1/D..07.A.	190.5	60	123	497.5	99	119	539.5	600	637.5	-
BM20Z-.1/D..07.A.	190.5	102	123	539.5	99	119	581.5	642	679.5	-
BM20-.1/D..08.A.	199.5	64	156	510.5	114.5	136.5	576.5	622.5	684	-
BM20Z-.1/D..08.A.	199.5	146	156	592.5	114.5	136.5	658.5	704.5	766	-
BM20-.1/S..08.A.	199.5	64	156	510.5	114.5	136.5	576.5	622.5	684	-
BM20Z-.1/S..08.A.	199.5	146	156	592.5	114.5	136.5	658.5	704.5	766	-
BM20-.1/D..08.B.	229.5	64	156	540.5	114.5	136.5	606.5	652.5	713.5	-
BM20Z-.1/D..08.B.	229.5	146	156	622.5	114.5	136.5	688.5	734.5	795.5	-
BM20-.1/S..08.B.	229.5	64	156	540.5	114.5	136.5	606.5	652.5	713.5	-
BM20Z-.1/S..08.B.	229.5	146	156	622.5	114.5	136.5	688.5	734.5	795.5	-
BM20-.1/D..09.A.	250.5	78.5	176	576	124	157	742.5	683.5	773	-
BM20-.1/D..09.B.	308.5	78.5	176	634	124	157	621	741	831	-
BM20-.1/S..09.A.	250.5	78.5	176	576	124	157	742.5	683.5	773	-
BM20-.1/S..09.B.	308.5	78.5	176	634	124	157	621	741	831	-

Dimensions in millimetres (mm)

The actual gearbox design can vary from the geometry shown. Generate drive specific 3D and 2D geometries under [www.BauerCat.com](http://www.BauerCat.com).





# Electric overhead conveyors series BM

## Dimension - Standard

### BM30-BM30Z

Flange with tapped holes at front

Code -7.V/

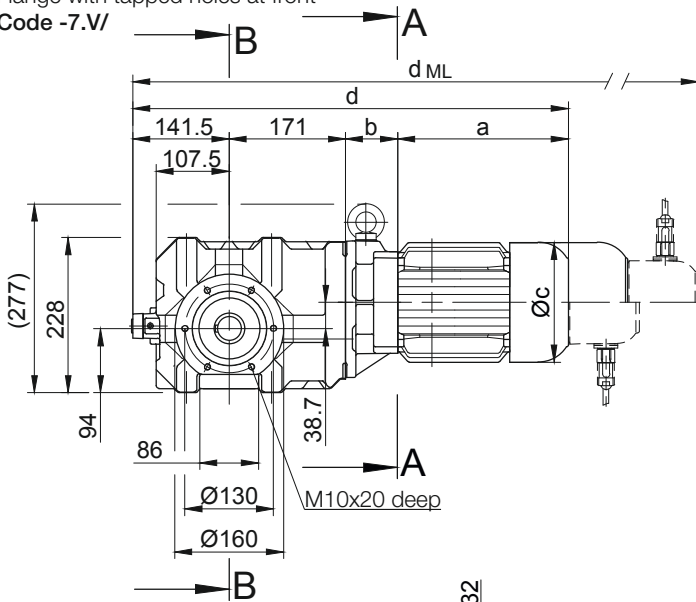

Code -1/

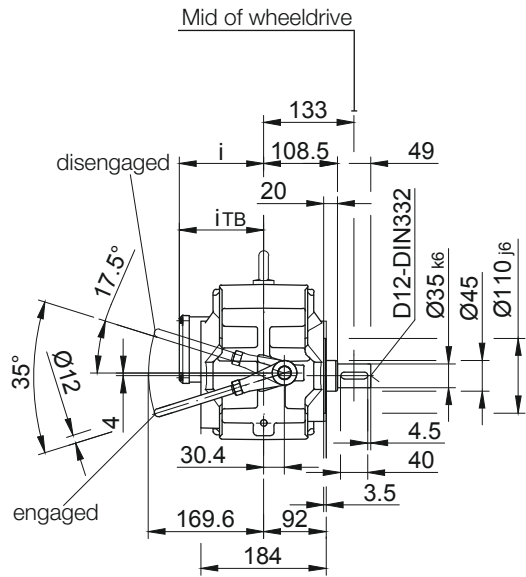
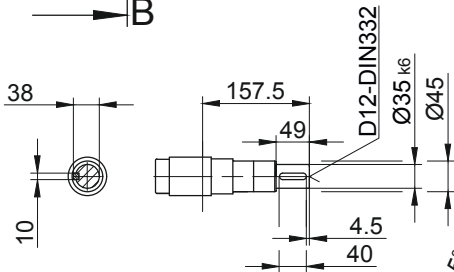

Code -3/

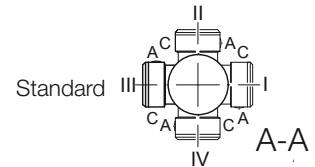
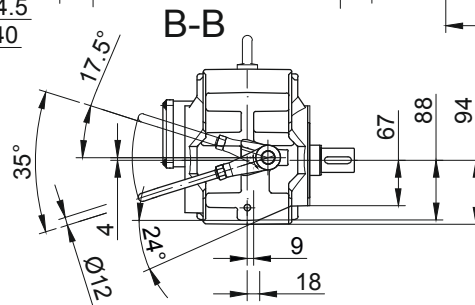
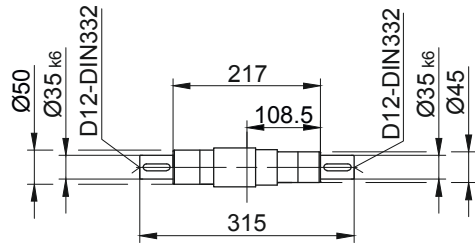

Type	a	b	c	d	i	Design with motor extensions				
						i <sub>TB</sub>	Brake	Encoder	Brake with Encoder	Back Stop
							d <sub>ML</sub>	d <sub>ML</sub>	d <sub>ML</sub>	d <sub>ML</sub>
BM30-../D..05.A.	170.5	58	123	541	101	117	583	643.5	681	-
BM30Z-../D..05.A.	170.5	133.5	123	616.5	101	117	658.5	719	756.5	-
BM30-../D..06.A.	170.5	58	123	541	99	119	583	643.5	681	-
BM30Z-../D..06.A.	170.5	133.5	123	616.5	99	119	658.5	719	756.5	-
BM30-../S..06.A.	170.5	58	123	541	99	119	583	643.5	681	-
BM30Z-../S..06.A.	170.5	133.5	123	616.5	99	119	658.5	719	756.5	-
BM30-../D..07.A.	190.5	58	123	561	99	119	603	663.5	701	-
BM30Z-../D..07.A.	190.5	133.5	123	636.5	99	119	678.5	739	776.5	-
BM30-../D..08.A.	199.5	62	156	574	114.5	136.5	640	686	747.5	-
BM30Z-../D..08.A.	199.5	137.5	156	649.5	114.5	136.5	715.5	761.5	823	-
BM30-../S..08.A.	199.5	62	156	574	114.5	136.5	640	686	747.5	-
BM30Z-../S..08.A.	199.5	137.5	156	649.5	114.5	136.5	715.5	761.5	823	-
BM30-../D..08.B.	229.5	62	156	604	114.5	136.5	670	716	777	-
BM30Z-../D..08.B.	229.5	137.5	156	679.5	114.5	136.5	745.5	791.5	852.5	-
BM30-../S..08.B.	229.5	62	156	604	114.5	136.5	670	716	777	-
BM30Z-../S..08.B.	229.5	137.5	156	679.5	114.5	136.5	745.5	791.5	852.5	-
BM30-../D..09.A.	250.5	76.5	176	639.5	124	157	732.5	747	836.5	-
BM30Z-../D..09.A.	250.5	152	176	715	124	157	808	822.5	912	-
BM30-../S..09.A.	250.5	76.5	176	639.5	124	157	732.5	747	836.5	-
BM30Z-../S..09.A.	250.5	152	176	715	124	157	808	822.5	912	-
BM30-../D..09.B.	308.5	76.5	176	697.5	124	157	790.5	804.5	894.5	-
BM30Z-../D..09.B.	308.5	152	176	773	124	157	866	880	970	-
BM30-../S..09.B.	308.5	76.5	176	697.5	124	157	790.5	804.5	894.5	-
BM30Z-../S..09.B.	308.5	152	176	773	124	157	866	880	970	-
BM30-../D..11.A.	319	83	218	714.5	165	176	812.5	822	914.5	-
BM30-../D..11.B.	387	83	218	782.5	165	176	878.5	890	982.5	-

Dimensions in millimetres (mm)

The actual gearbox design can vary from the geometry shown. Generate drive specific 3D and 2D geometries under [www.BauerCat.com](http://www.BauerCat.com).

# Electric overhead conveyors series BM

## Dimension - Standard

### BM30-BM30Z

Foot with tapped holes at bottom and top

Code -6.UO/

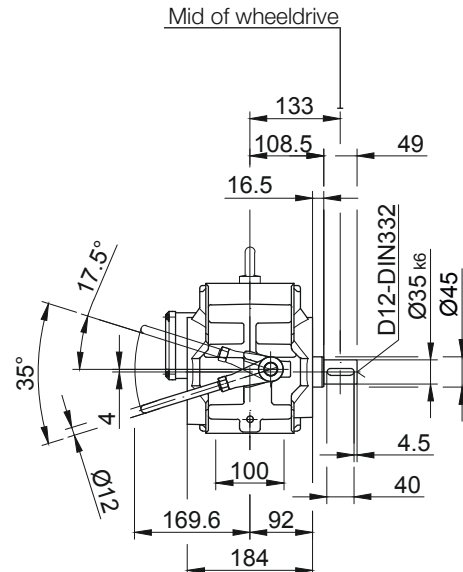
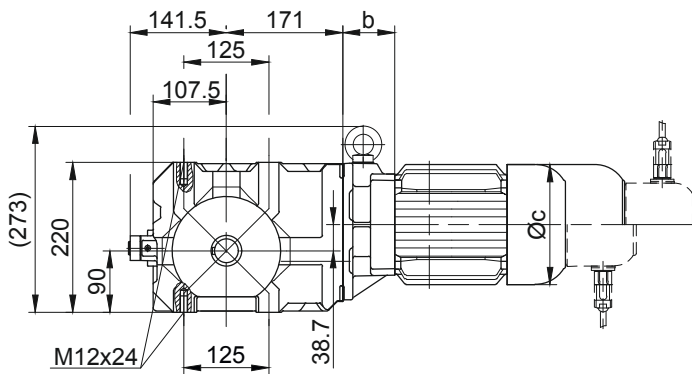

drawn flange at front

Code -07V.../S01

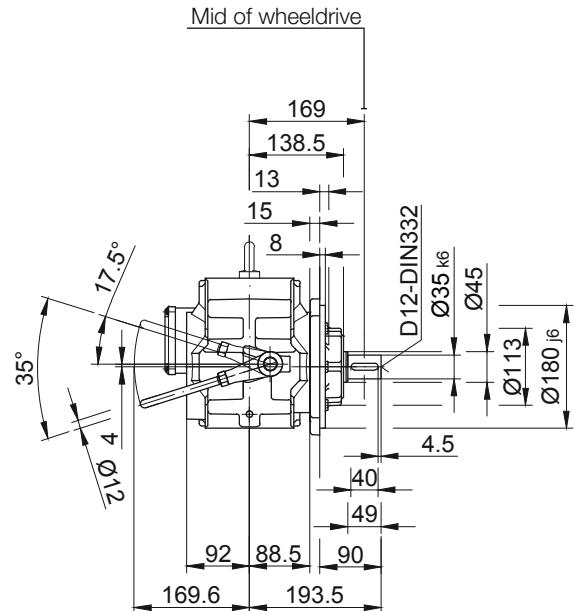
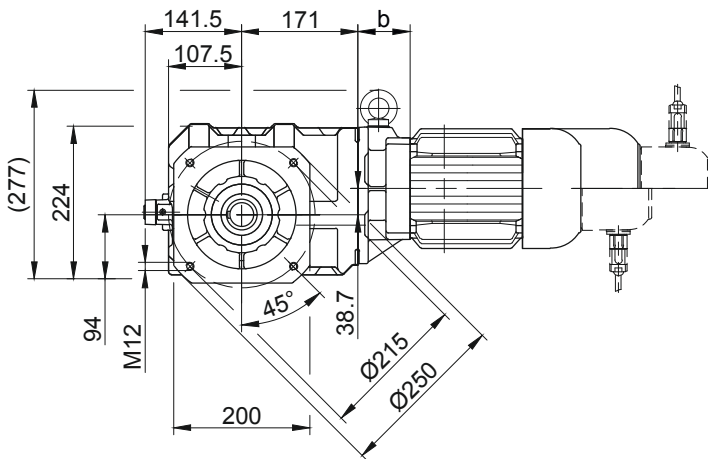

far drawn flange at front

Code -07V.../S02

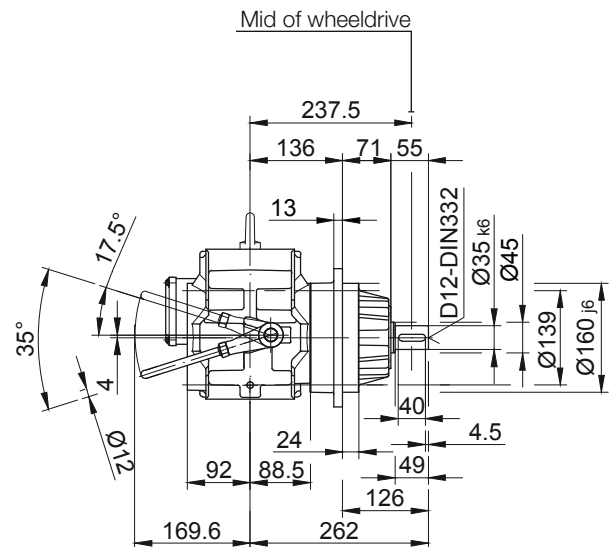
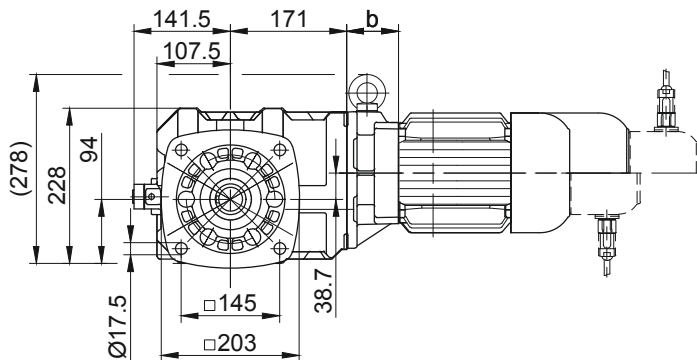

Flange Dimensions		k	l	m	n	o	p	q	s	t
BM30..	Code -3.V/	250	215	180	16	13.5	276	152	4	78
BM30..	Code -4.V/	300	265	230	20	13.5	282	158	4	72

Dimensions in millimetres (mm)

The actual gearbox design can vary from the geometry shown. Generate drive specific 3D and 2D geometries under [www.BauerCat.com](http://www.BauerCat.com).

# Electric overhead conveyors series BM

## Dimension - Standard

### BM40-BM40Z

Flange with threaded holes at the front

Code -7.V/

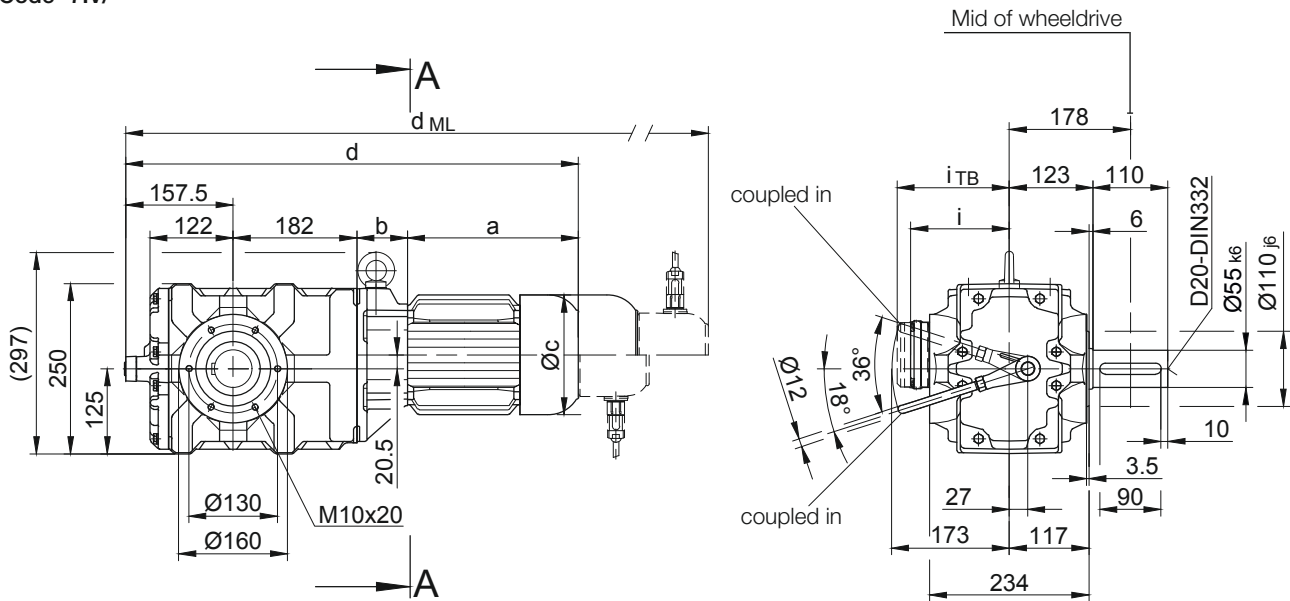

Code -1/

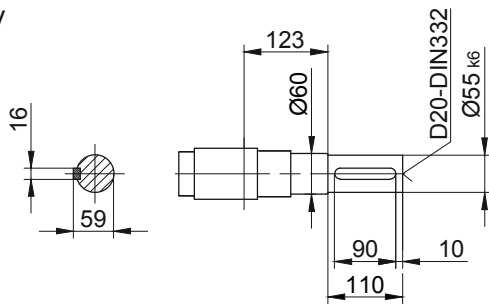

Code -3/

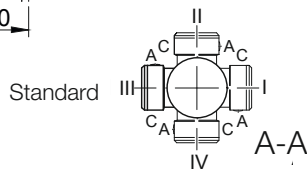
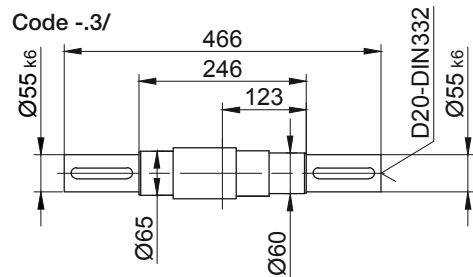

Type	a	b	c	d	i	Design with motor extensions				
						i <sub>TB</sub>	Brake	Encoder	Brake with Encoder	Back Stop
							d <sub>ML</sub>	d <sub>ML</sub>	d <sub>ML</sub>	d <sub>ML</sub>
BM40Z-../D..05.A.	170.5	138.5	123	648.5	101	117	690.5	751	788.5	-
BM40Z-../D..06.A.	170.5	138.5	123	648.5	99	119	690.5	751	788.5	-
BM40Z-../S..06.A.	170.5	138.5	123	648.5	99	119	690.5	751	788.5	-
BM40Z-../D..07.A.	190.5	138.5	123	668.5	99	119	710.5	771	808.5	-
BM40-../D..08.A.	199.5	60	156	599	114.5	136.5	665	711	772.5	-
BM40Z-../D..08.A.	199.5	142.5	156	681.5	114.5	136.5	747.5	793.5	855	-
BM40-../S..08.A.	199.5	60	156	599	114.5	136.5	665	711	772.5	-
BM40Z-../S..08.A.	199.5	142.5	156	681.5	114.5	136.5	747.5	793.5	855	-
BM40-../D..08.B.	229.5	60	156	629	114.5	136.5	695	741	802	-
BM40Z-../D..08.B.	229.5	142.5	156	711.5	114.5	136.5	777.5	823.5	884.5	-
BM40-../S..08.B.	229.5	60	156	629	114.5	136.5	695	741	802	-
BM40Z-../S..08.B.	229.5	142.5	156	711.5	114.5	136.5	777.5	823.5	884.5	-
BM40-../D..09.A.	250.5	74.5	176	664.5	124	157	757.5	772	861.5	-
BM40Z-../D..09.A.	250.5	157	176	747	124	157	840	854.5	944	-
BM40-../S..09.A.	250.5	74.5	176	664.5	124	157	757.5	772	861.5	-
BM40Z-../S..09.A.	250.5	157	176	747	124	157	840	854.5	944	-
BM40-../D..09.B.	308.5	74.5	176	722.5	124	157	815.5	829.5	919.5	-
BM40Z-../D..09.B.	308.5	157	176	805	124	157	898	912	1002	-
BM40-../S..09.B.	308.5	74.5	176	722.5	124	157	815.5	829.5	919.5	-
BM40Z-../S..09.B.	308.5	157	176	805	124	157	898	912	1002	-
BM40-../D..11.A.	319	81	218	739.5	165	176	837.5	847	939.5	-
BM40-../D..11.B.	387	81	218	807.5	165	176	903.5	915	1007.5	-

Dimensions in millimetres (mm)

The actual gearbox design can vary from the geometry shown. Generate drive specific 3D and 2D geometries under [www.BauerCat.com](http://www.BauerCat.com).

# Electric overhead conveyors series BM

## Dimension - Standard

### BM40-BM40Z

Foot with threaded holes at the bottom and top

Code -6.UO/

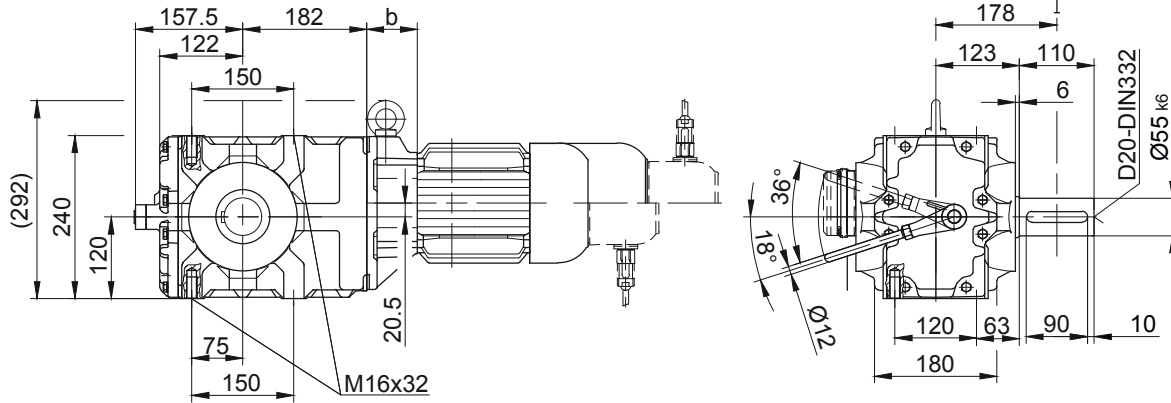

Front flange

Code -07V/.../S01

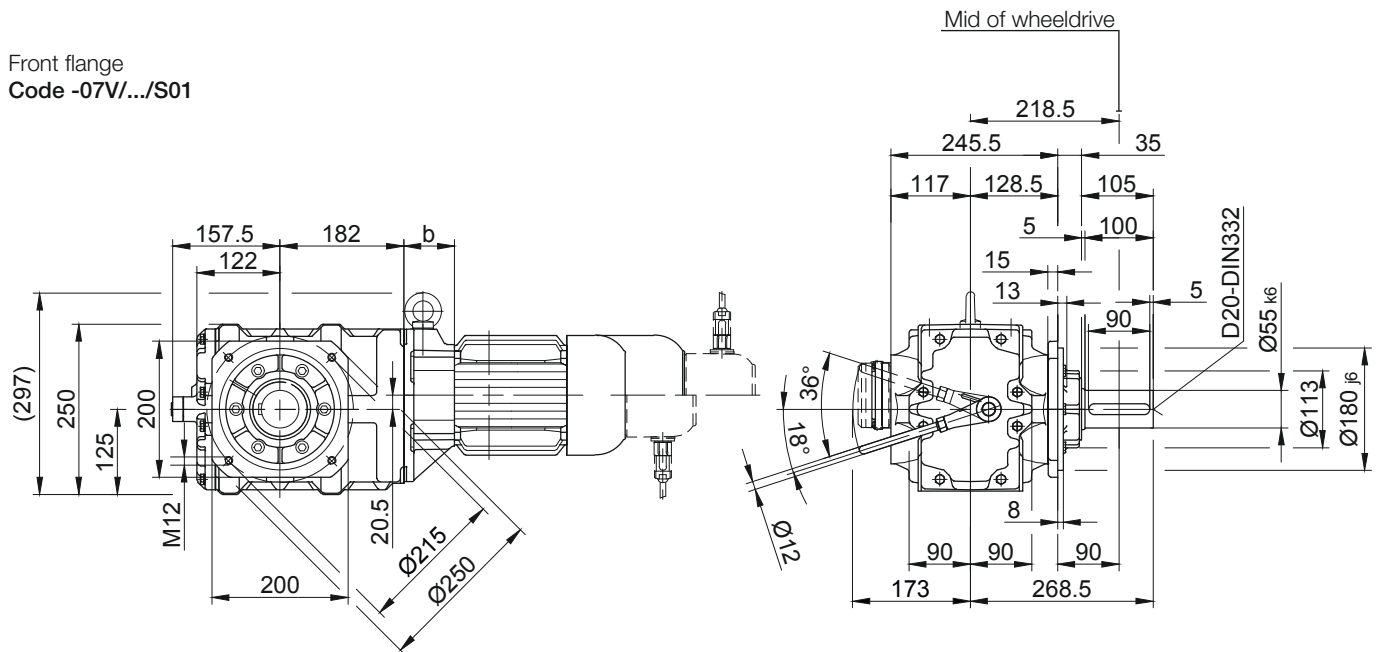

wde forward flange at the front

Code -07V/.../S02

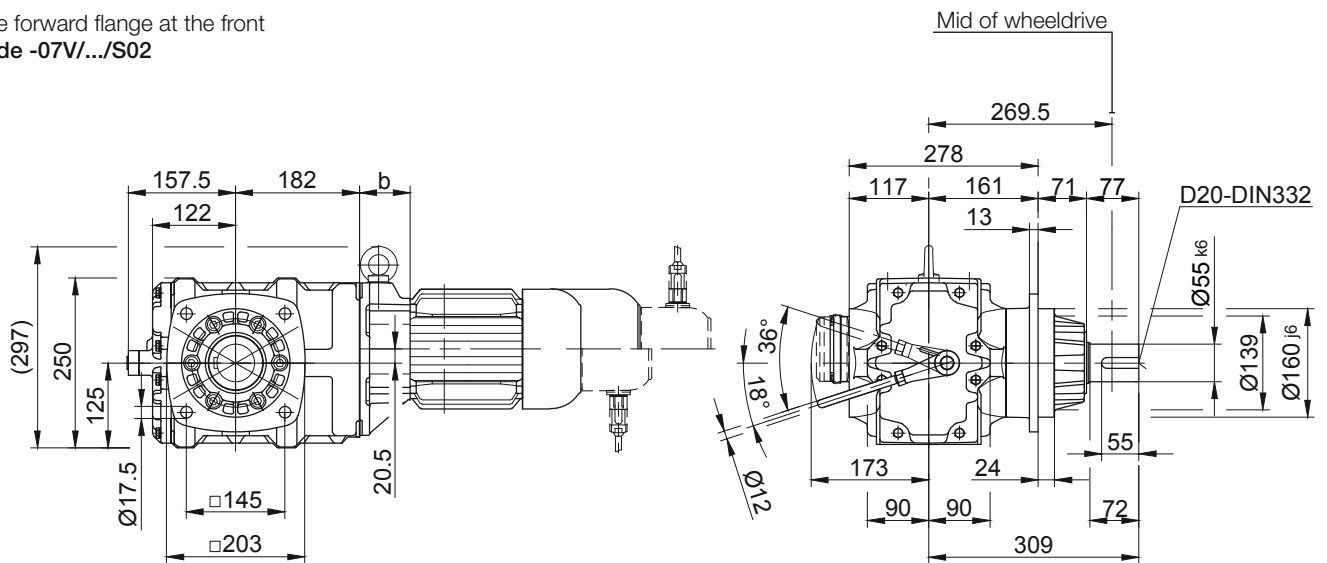

#### Flange Dimensions

Type	Design	k	l	m	n	o	p	q	s	t
BM40..	Code -3.V/	250	215	180	16	13.5	276	152	4	78
BM40..	Code -4.V/	300	265	230	20	13.5	282	158	4	72

Dimensions in millimetres (mm)

The actual gearbox design can vary from the geometry shown. Generate drive specific 3D and 2D geometries under [www.BauerCat.com](http://www.BauerCat.com).

# Electric overhead conveyors series BM

## Additional Dimension Sheet

### Standard terminal box

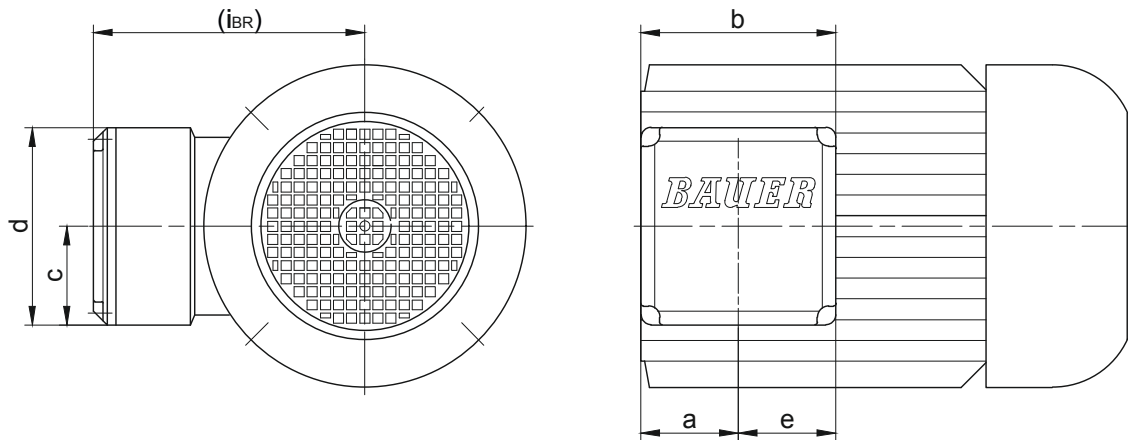

Motor/		Dimensions (mm)						Code	Cable entry		max. spanner width for cable entry gland
ASM	PMSM	a	b	c	d	e	i/iBR		Major (M)	Next to (N)	
Motor with brake											
D..04..	S..04..	42.5	88	44	88	44	90	KAG1	M=2xM20x1.5	-	24 mm
D..05..	-	50	100	50	100	50	100	KAG2	M=2xM20x1.5	-	29 mm
D..06..	S..06..	50	100	50	100	50	100	KAG2	M=2xM20x1.5	-	29 mm
D..07..	-		100	50	100	50	100	KAG2	M=2xM20x1.5	-	29 mm
D..08..	S..08..	50	100	50	100	50	115	KAG2	M=2xM20x1.5	-	29 mm
D..09..	S..09..	50	100	50	100	50	124	KAG2	M=2xM20x1.5	-	29 mm
D..11..	S..11..	66.5	133	66.5	133	66.5	165	KAG3	M=2xM32x1.5	-	-

# Electric overhead conveyors series BM

## Additional Dimension Sheet

### Plug-connector terminal box

Standard design (two brackets)

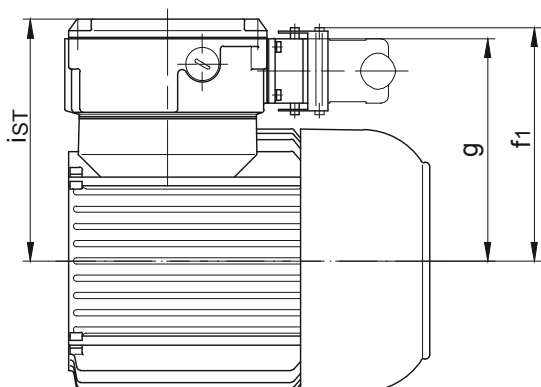

Optional for DESINA (one bracket)

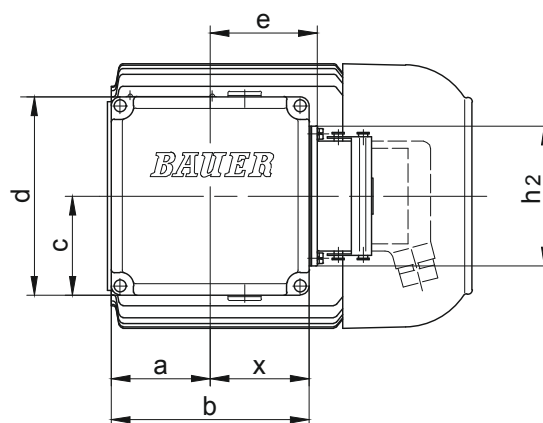
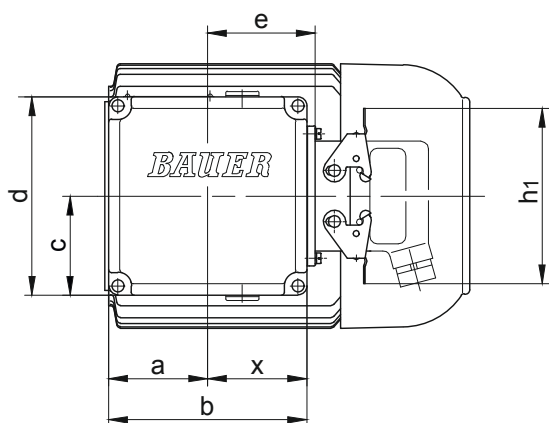
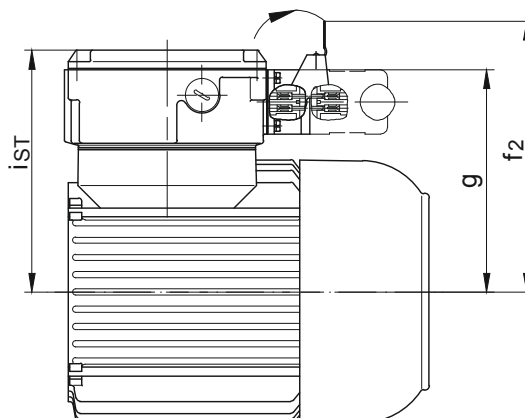

10

Motor		Size Terminal box	a	b	c	d	e	f <sub>1</sub>	f <sub>2</sub>	g	h <sub>1</sub>	h <sub>2</sub>	ist	x
ASM	PMSM													
D..04..	S..04..	TBS1	30	90	52.5	106	49	118.5	147	111	117	93	124.5	46
D..05..	-	TBS1	57	90	52.5	106	49	123.5	152	116	117	93	129.5	46
D..06..	S..06..	TBS1	45	90	52.5	106	49	125.5	154	118	117	93	131.5	46
D..07..	-	TBS1	45	90	52.5	106	49	125.5	154	118	117	93	131.5	46
D..08..	S..08..	TBS1	45	90	52.5	106	49	143.5	172	136	117	93	149.5	46
D..09..	S..09..	TBS2	62	132	66	135	71.5	158.5	187	158	117	93	164	68.5
D..11..	S..11..	TBS2	62	132	66	135	71.5	175.5	191	166	117	93	181	68.5

Dimensions in millimetres (mm)

# Electric overhead conveyors series BM

## Additional Dimension Sheet

### Standard brakes

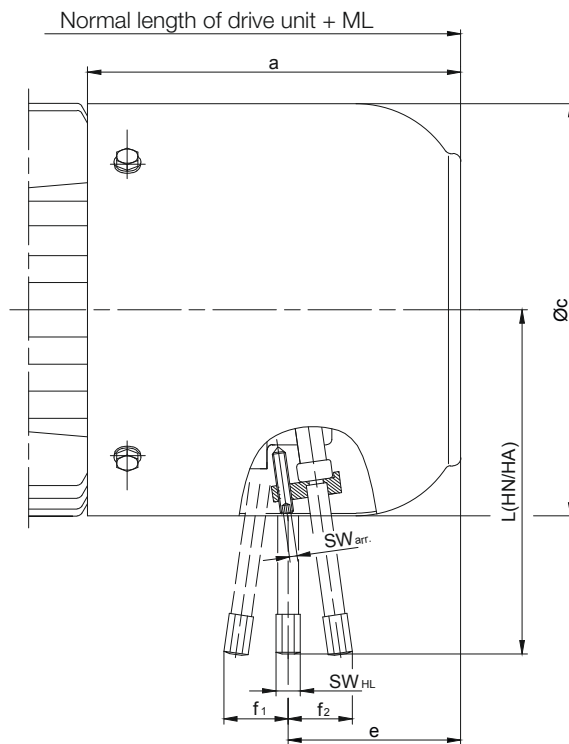

Motor		Brake	ML (mm) Additional length with brake	Dimensions (mm)								Additional weight kg
ASM	PMSM			a	Øc	e	f <sub>1</sub>	f <sub>2</sub>	L(HA/HN)	SW <sub>HL</sub>	SW <sub>arr.</sub>	
D..04..	S..04..	E003	43.5	97	110.5	58.5	20.5	24	96/102	11	11	1.0
D..05..	-		60									
D..06..	S..06..		42	102	123	58.5						
D..07..	-	E003/E004										
D..08..	S..08..	ES(X)010	66	141	156	68	-	29	132	8	2.5	2.6
D..09..	S..09..	ES(X)010	93	173	176	99	-	29	132	8	2.5	2.7
		ES(X)027				91	-	35.5	162			4.2
D..11..	S..11..	ES(X)027	98	195	218	103	-	35.5	162	8	2.5	4.5
		ES(X)040				100	-	37	172			6.3
		ES(X)070				96	-	34.5	190			12

HA = manual release lockable  
HN = manual release not lockable



# Electric overhead conveyors series BM

## Additional Dimension Sheet

“Heavy-Duty“- brake

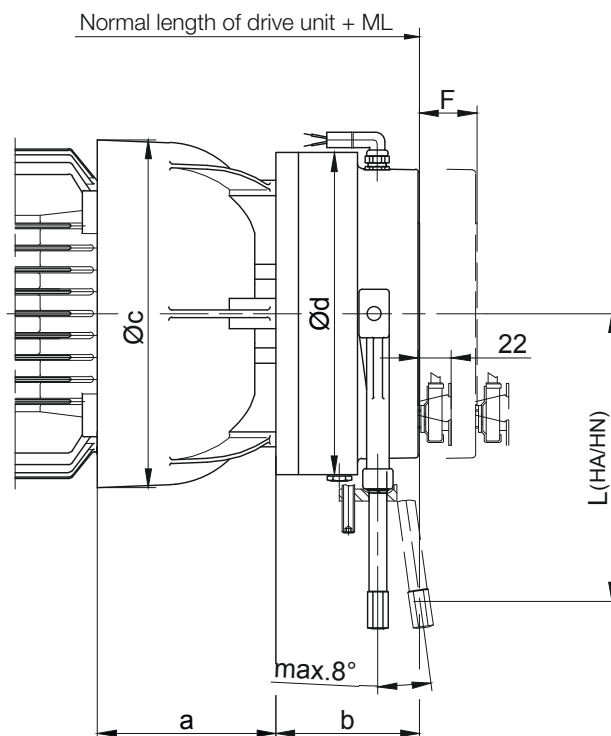

Motor		Brake	Additional length with brake (mm)		Dimensions (mm)					Additional weight kg
ASM	PMSM		ML Standard	ML Microswitch	a	b	c	Ød	L (HA/HN)	
D..08..	S..08..	EH(X)027	79	101	83.5	66.5	166	145	162	5.5
D..09..	S..09..	EH(X)040	90	112	102	73	191	168	172	8.3
D..11..	S..11..	EH(X)125	114	136	120	95	231	213	208.5	19.5

HA = manual release lockable  
HN = manual release not lockable

10

# Electric overhead conveyors series BM

## Additional Dimension Sheet

Motors with back stop

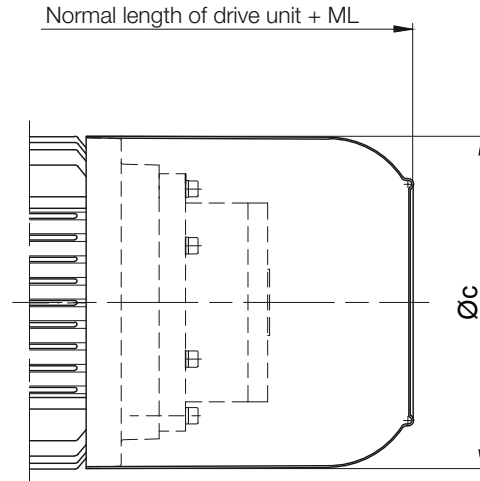

10

Motor		ML (mm)	Dimensions (mm)	Additional weight
ASM	PMSM	Additional length with backstop	c	kg
D..08..	S..08..	66	156	6.5
D..09..	S..09..	93	181	6.5
D..11..	S..11..	98	228	8

The actual gearbox design can vary from the geometry shown. Generate drive specific 3D and 2D geometries under [www.BauerCat.com](http://www.BauerCat.com).

# Electric overhead conveyors series BM

## Additional Dimension Sheet

### Motors with second shaft end

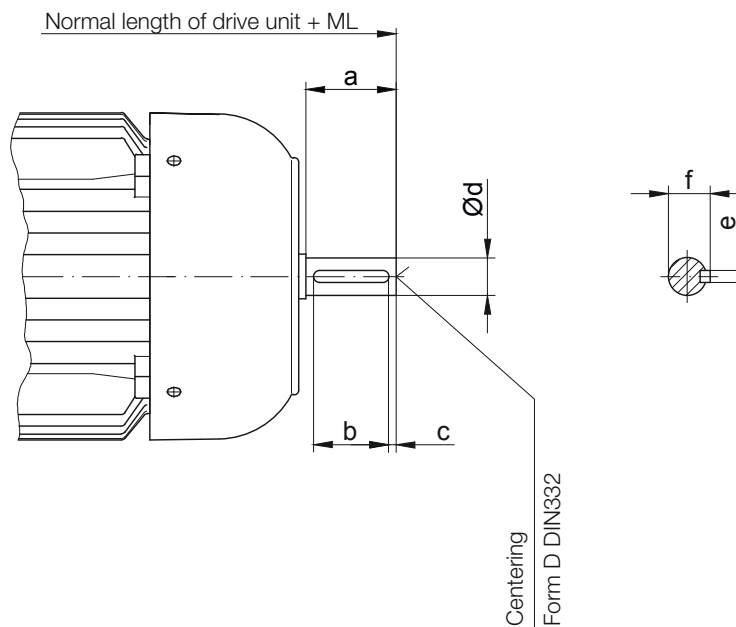

Motor		ML (mm) Additional length with second shaft end	Dimensions (mm)							Centering DIN 332
ASM	PMSM		a	b	c	d	e	f		
D..04..	S..04..	20	15	-	-	8 <sub>g6</sub>	-	-	-	
D..05..	-	25	20	-	-	10 <sub>k6</sub>	-	-	-	
D..06..	S..06..	25	20	-	-	10 <sub>k6</sub>	-	-	-	
D..07..	-	25.5	20	-	-	10 <sub>k6</sub>	-	-	-	
D..08..	S..08..	45	40	30	5	16 <sub>k6</sub>	5	18	D5	
D..09..	S..09..	55	50	40	5	20 <sub>k6</sub>	6	22.5	D5	
D..11..	S..11..	65	60	50	5	25 <sub>k6</sub>	8	28	D8	

10

# Electric overhead conveyors series BM

## Additional Dimension Sheet

### Motors with brake and second shaft end

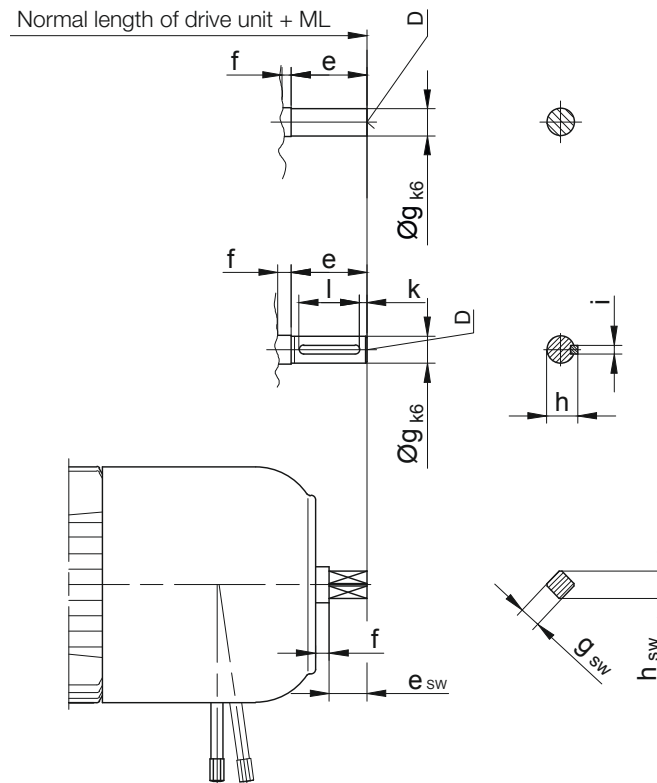

10

Motor		Brake	Additional length (mm)		Dimensions (mm)										Centering	
ASM	PMSM		ML	ML <sub>SW</sub>	e	e <sub>SW</sub>	f	g	g <sub>SW</sub>	h	h <sub>SW</sub>	i	k	l	DIN 332	SW
D..04..	S..04..	E003	63	-	15	-	5	8	-	-	-	-	-	-	-	-
D..05..	-				20			10								
D..06..	S..06..															
D..07..	-	E003/E004														
D..08..	S..08..	ES(X)..	121	96*	50	25*	5	18	SW14*	20.5	18*	6	5	40	D6	D4*
D..09..	S..09..		98	123*				20*	SW14	22.5*	18	6*	5*	40*	D6*	D4
D..11..	S..11..		153.5*	128				50*	25							

\* special design with manual release

# Electric overhead conveyors series BM

## Additional Dimension Sheet

Motors with "heavy duty" brake and second shaft end

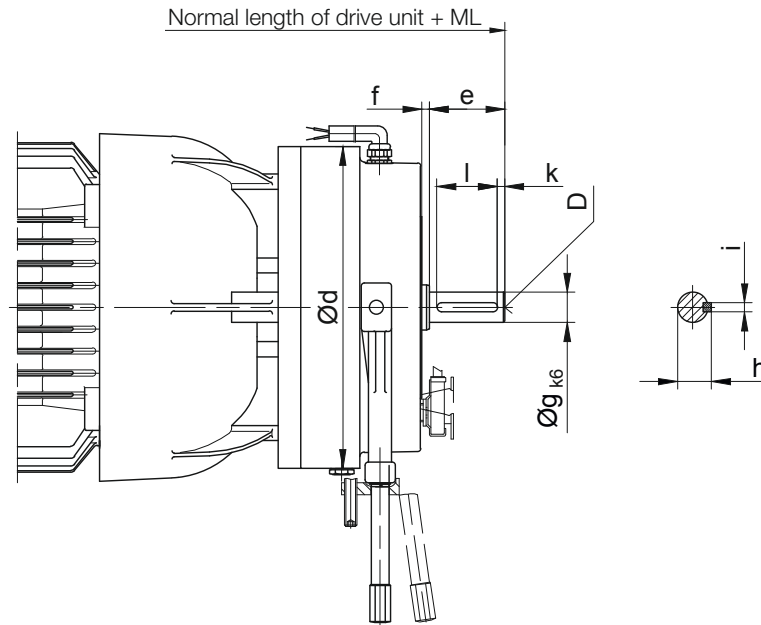

Motor		Brake	ML (mm) Additional length with encoder and brake	Dimensions (mm)								Centering D 332	Additional weight kg
ASM	PMSM			Ød	e	f	Øg	h	i	k	k		
D..08..	S..08..	EH(X)027	132	145	50	4	18	20.5	6	5	6	D6	6
D..09..	S..09..	EH(X)040	144	168		5							20
D..11..	S..11..	EH(X)125	169	213									20

10

# Electric overhead conveyors series BM

## Additional Dimension Sheet

### Motors with protective hood

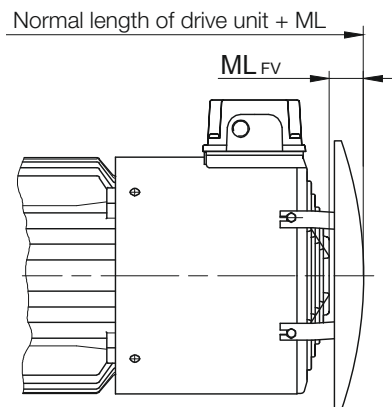
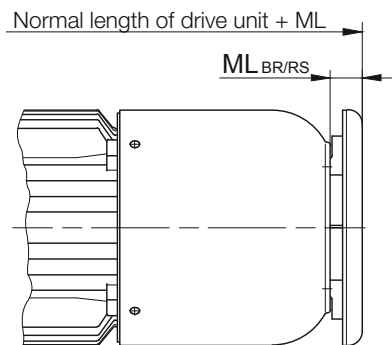
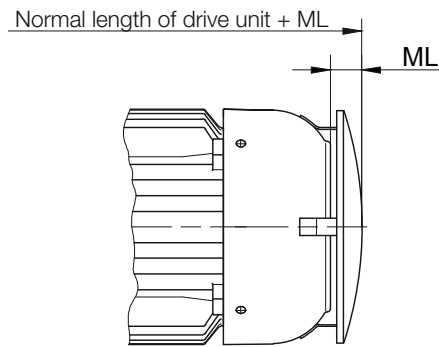

10

Motor		ML (mm)				Additional weight kg
ASM	PMSM	Additional length with attached protective cover				
		ML	ML <sub>BR</sub>	ML <sub>RS</sub>	ML <sub>FV</sub>	
D..04..	S04..	16	-	-	-	0.15
D..05..	-	18				0.15
D..06..	S..06..	18	-	-	-	0.15
D..07..	-	18	-	-	-	0.15
D..08..	S..08..	14.5	24.5	24.5	40	0.20
D..09..	S..09..	22	24.5	24.5	30	0.30
D..11..	S..11..	29	29.5	29.5	33	0.40

# Electric overhead conveyors series BM

## Additional Dimension Sheet

### Motors with independent fan

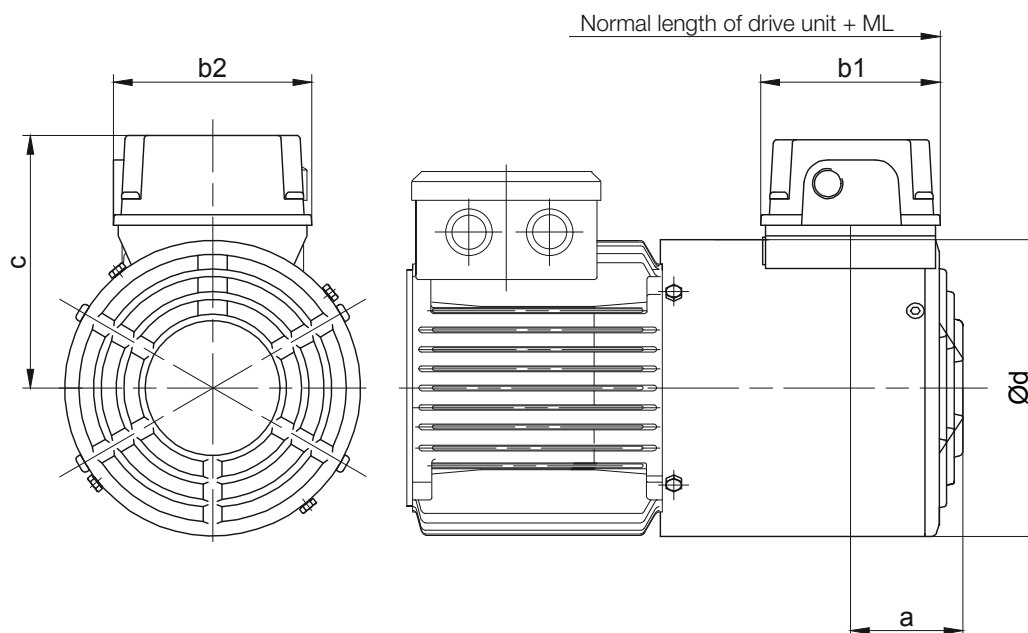

Drive Motor		Fan Motor	kW	r/min	400 V A	ML (mm) Additional length with forced cooling fan	Dimensions (mm)					Additional weight ~kg
ASM	PMSM						a	b1	b2	c	d	
D..08..	S..08..	FV D08	0.019	2670	0.029	92	69.5	107	105	134	157	2.2
D..09..	S..09..	FV D09	0.046	2820	0.106	97	69.5	107	105	143	177	2.7
D..11..	S..11..	FV D11	0.051	2660	0.110	97	79.5	107	105	162.5	219	3.2

10

# Electric overhead conveyors series BM

## Additional Dimension Sheet

Motors with brake and independent fan

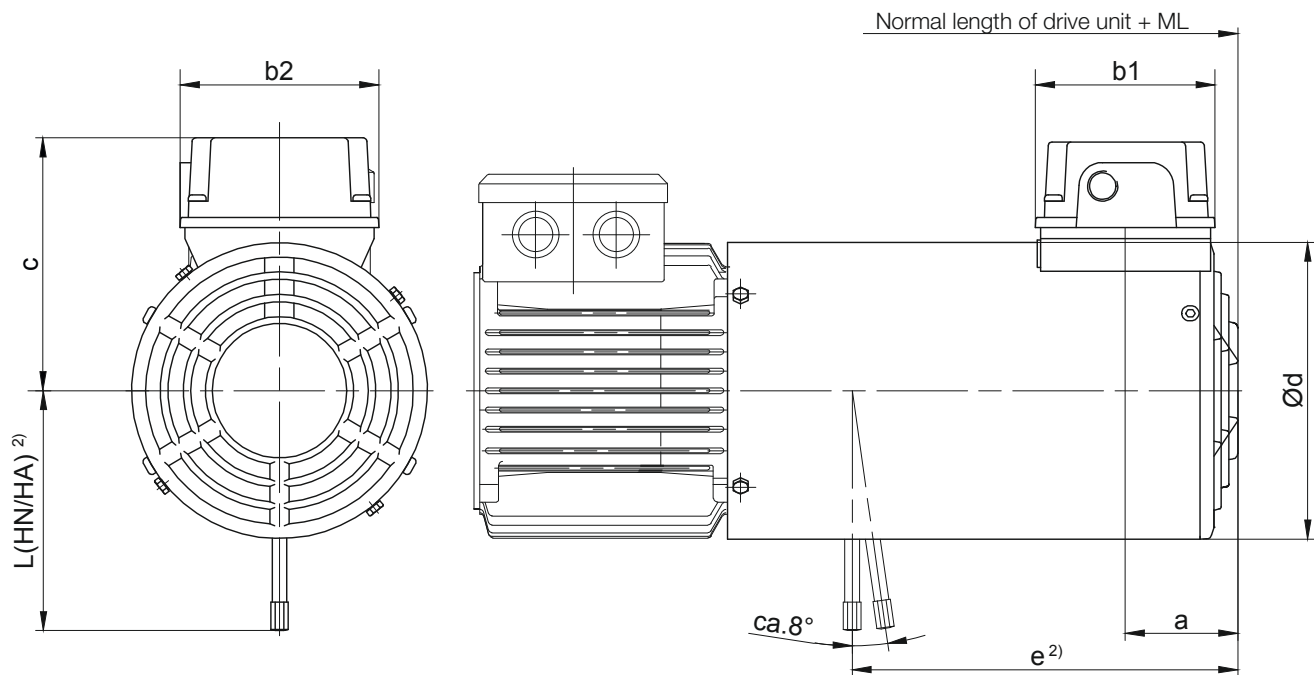

Motor		Brake	ML (mm) <sup>1)</sup>	Dimensions (mm)							Additional weight
ASM	PMSM		Additional length with brake and forced ventilation	a	b1	b2	c	Ød	e <sup>2)</sup>	L(HA/HN) <sup>2)</sup>	~kg
D..08..	S..08..	ES(X)010	202	59	107	105	134	157	204	132	5.0
D..09..	S..09..	ES(X)010	214	69.5	107	105	143	177	220	132	5.5
		ES(X)027							212	162	7.5
D..11*	S..11*	ES(X)027	221	69.5	107	105	162.5	219	226	162	8.0
		ES(X)040							223	172	10
		ES(X)070							218	184	12

\* with bayonet joint

<sup>1)</sup> The additional length is for normal motor unit without brake.  
Other dimensions see the appropriate normal dimensioned sketch.

<sup>2)</sup> Brake release on request

HA = manual release lockable

HN = manual release not lockable



# Electric overhead conveyors series BM

## Additional Dimension Sheet

### Motors with encoder and built-on independent fan

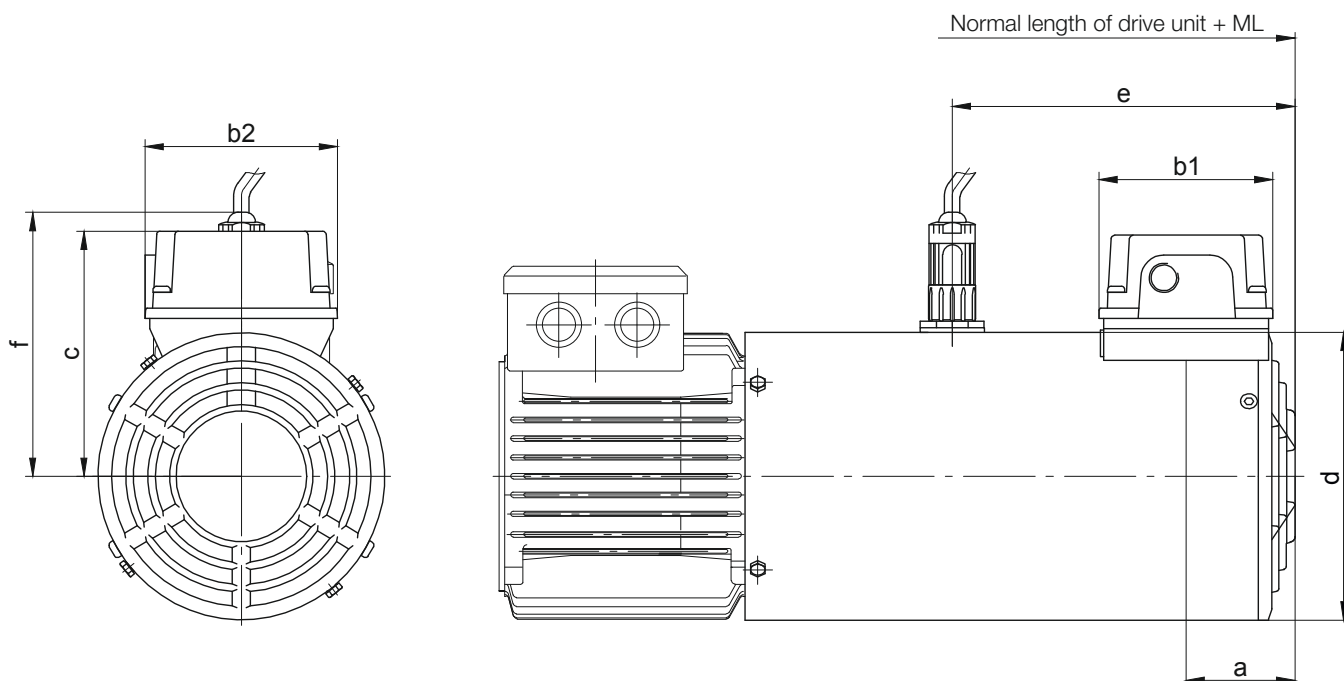

Motor		ML (mm) <sup>1)</sup> Additional length with encoder and forced ventilation	Dimensions (mm)							Additional weight ~kg
ASM	PMSM		a	b1	b2	c	d	e	f	
D..08..	S..08..	202	59	107	105	134	157	187	144	2.6
D..09..	S..09..	214	69.5	107	105	143	177	192	153.5	3.3
D..11*	S..11*	221	69.5	107	105	162.5	218	192	-	4.0

\* with bayonet joint  
<sup>1)</sup> The additional length is for normal motor unit without brake.  
 Other dimensions see the appropriate normal dimensioned sketch.

10

# Electric overhead conveyors series BM

## Additional Dimension Sheet

Motors with brake and encoder with built-on independent fan

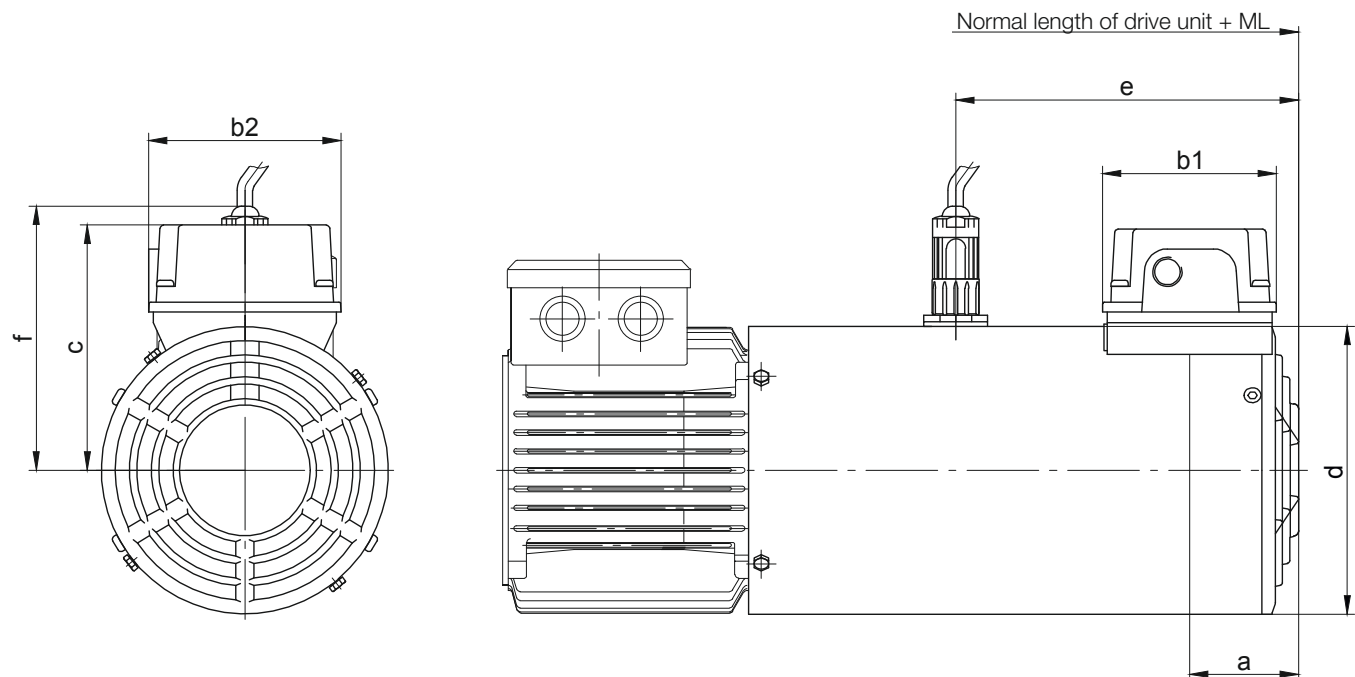

Motor		Brake	ML (mm) <sup>1)</sup>	Dimensions (mm)									Additional weight
ASM	PMSM		Additional length with brake, encoder and forced ventilation	a	b1	b2	c	Ød	e <sup>2)</sup>	g	h	L(HA/HN) <sup>2)</sup>	~kg
D..08..	S..08..	ES(X)010	202	59	107	105	134	157	204	150	150	132	6.0
D..09..	S..09..	ES(X)010	214	69.5	107	105	143	177	220	160	160	132	6.5
		ES(X)027							212	160		162	8.5
D..11*	S..11*	ES(X)027	221	69.5	107	105	162.5	219	226	155	175	162	9.0
		ES(X)040							223	155		172	11.5
		ES(X)070							218	155		184	13.5

\* with bayonet joint

<sup>1)</sup> The additional length is for normal motor unit without brake.

Other dimensions see the appropriate normal dimensioned sketch.

<sup>2)</sup> Brake release on request

HA = manual release lockable

HN = manual release not lockable

# Electric overhead conveyors series BM

## Additional Dimension Sheet

### Motors with standard encoder

D..04../S..04..

D..05../S..05.. - D ..11../S..11..

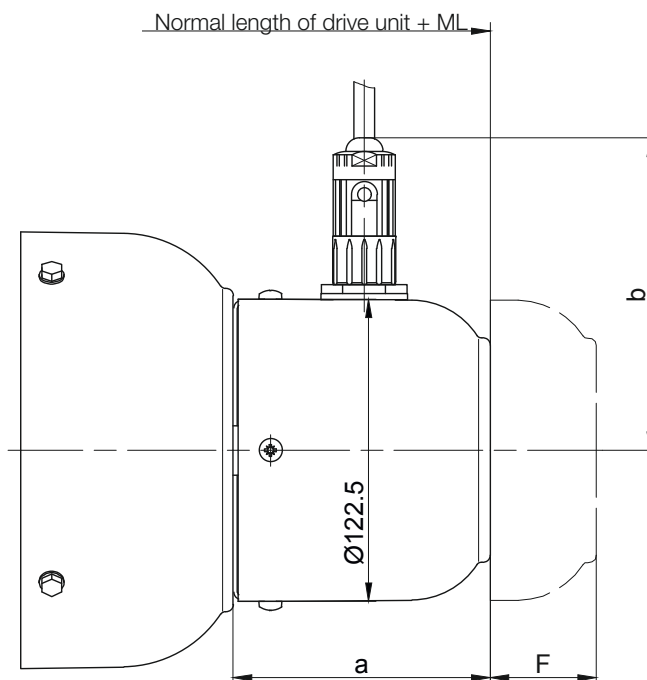
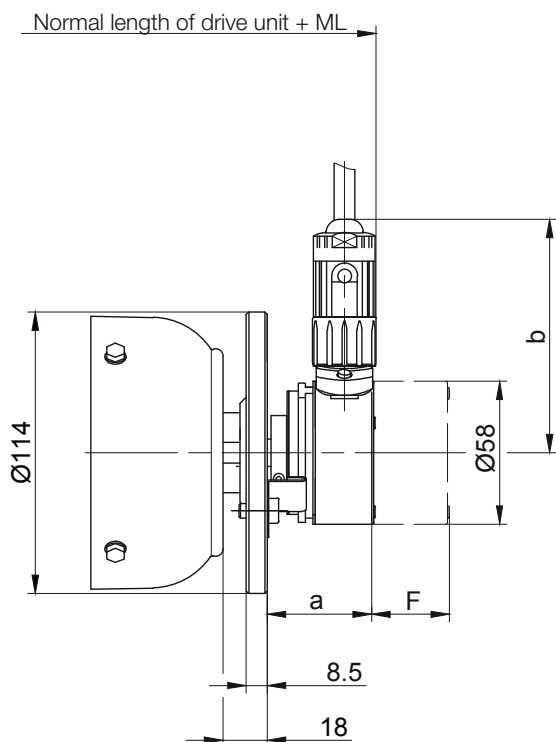

Motor		ML (mm) Additional length with encoder	Dimensions (mm)				Additional weight kg	Free space for removing encoder „F“	
ASM	PMSM		Incremental encoder		Absolute encoder			Incremental encoder	Absolute encoder
			a	c	a	b			
D..04..	S04..	62.5	43.5	95	69.5	109.5	0.7	30	55
D..05..	-	103	98.5	127	98.5	127	0.9	63	88
D..06..									
D..07..									
D..08..	S..08..	107	107.5	104	107.5	104	0.8	41	66
D..09..	S..09..								
D..11..	S..11..								

10

# Electric overhead conveyors series BM

## Additional Dimension Sheet

Motors with "heavy duty" encoder

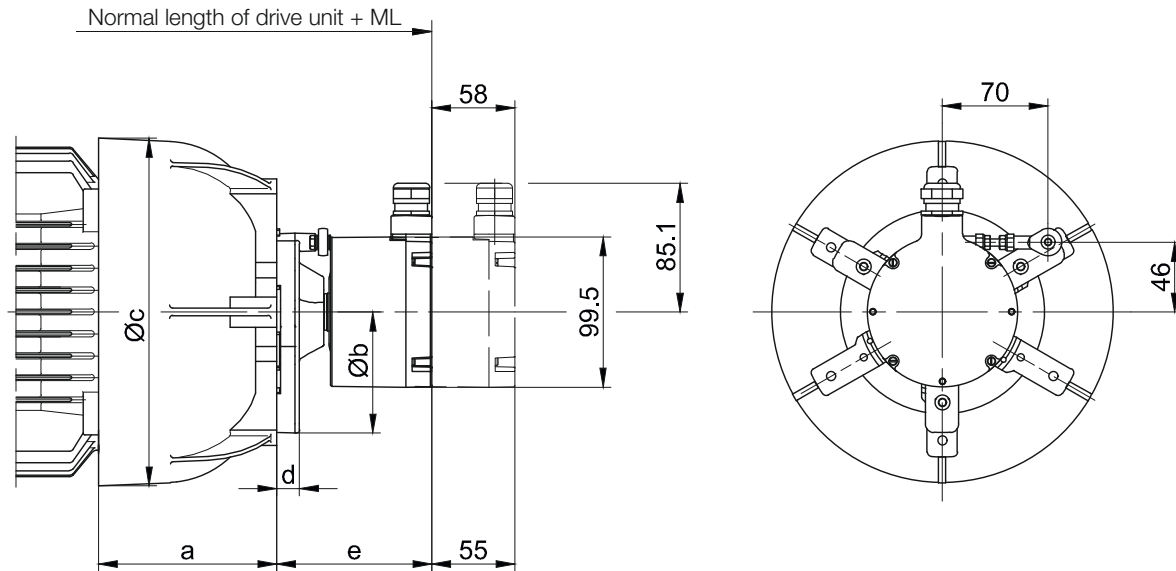

Motor		ML (mm) Additional length with encoder	Dimensions (mm)					Additional weight kg
ASM	PMSM		a	b	c	d	e	
D..08..	S..08..	114	83.5	160	166	15	102.5	2
D..09..	S..09..	118.5	102		191			
D..11..	S..11..	121.5	120		231			

The actual gearbox design can vary from the geometry shown. Generate drive specific 3D and 2D geometries under [www.BauerCat.com](http://www.BauerCat.com).

# Electric overhead conveyors series BM

## Additional Dimension Sheet

### Motors with brake and encoder

#### D..04..

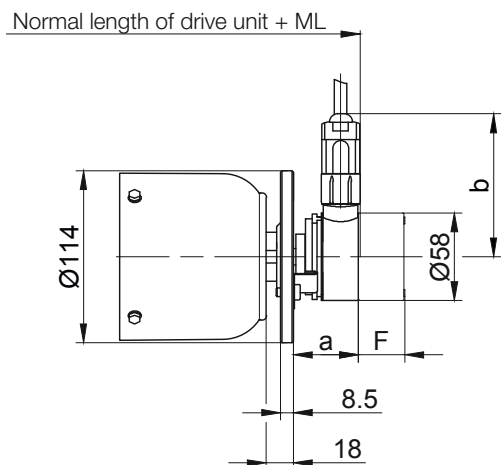

#### D..05../S..05.. - D..07../S..07..

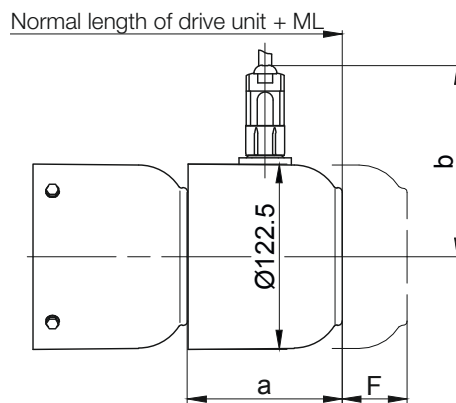

#### D..08../S..08.. - D..11../S..11..

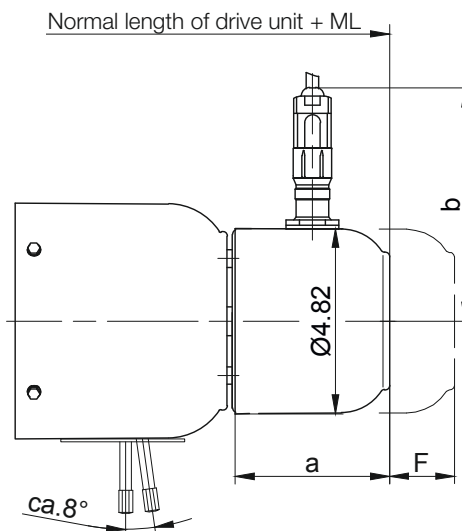
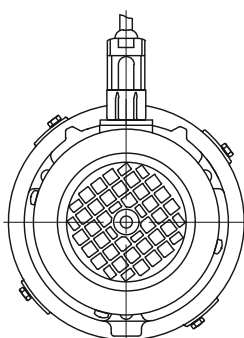

Motor		Brake	ML (mm) Additional length with brake and encoder	Dimensions (mm)				Additional weight kg	Free space for removing encoder „F“			
ASM	PMSM			Incremental encoder		Absolute encoder			Incremental encoder	Absolute encoder		
				a	c	a	b					
D..04..	S..04..	E003	105.5	43.5	95	69.5	109.5	0.7	30	55		
D..05..	-											
D..06..	S..06..			145					0.9	63	88	
D..07..	-	E003/E004		102	127	102	127					
D..08..	S..08..	ES(X)..	173.5					0.8	49	74		
D..09..	S..09..	ES(X)..	197									
D..11..	S..11..	ES(X)..	200									

10

# Electric overhead conveyors series BM

## Additional Dimension Sheet

Motors with "heavy duty" brake and encoder

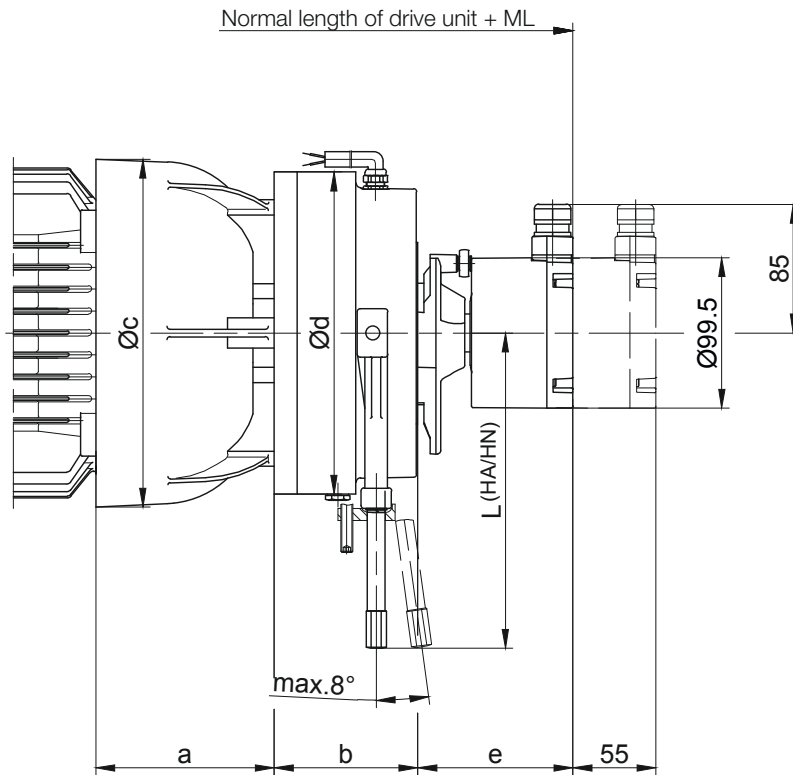

10

Motor		Brake	ML (mm)	Dimensions (mm)						Additional weight kg
ASM	PMSM			Additional length with brake and encoder	a	b	c	Ød	e	
D..08..	S..08..	EH(X)027	180.5	83.5	66.5	166	145	102.5	162	7.1
D..09..	S..09..	EH(X)040	191.5	102	73	191	168		172	10
D..11..	S..11..	EH(X)125	216.5	120	95	231	213		208.5	21.4

HA = manual release lockable  
HN = manual release not lockable

The actual gearbox design can vary from the geometry shown. Generate drive specific 3D and 2D geometries under [www.BauerCat.com](http://www.BauerCat.com).

# Electric overhead conveyors series BM

## Additional Dimension Sheet

Motors in IEC design

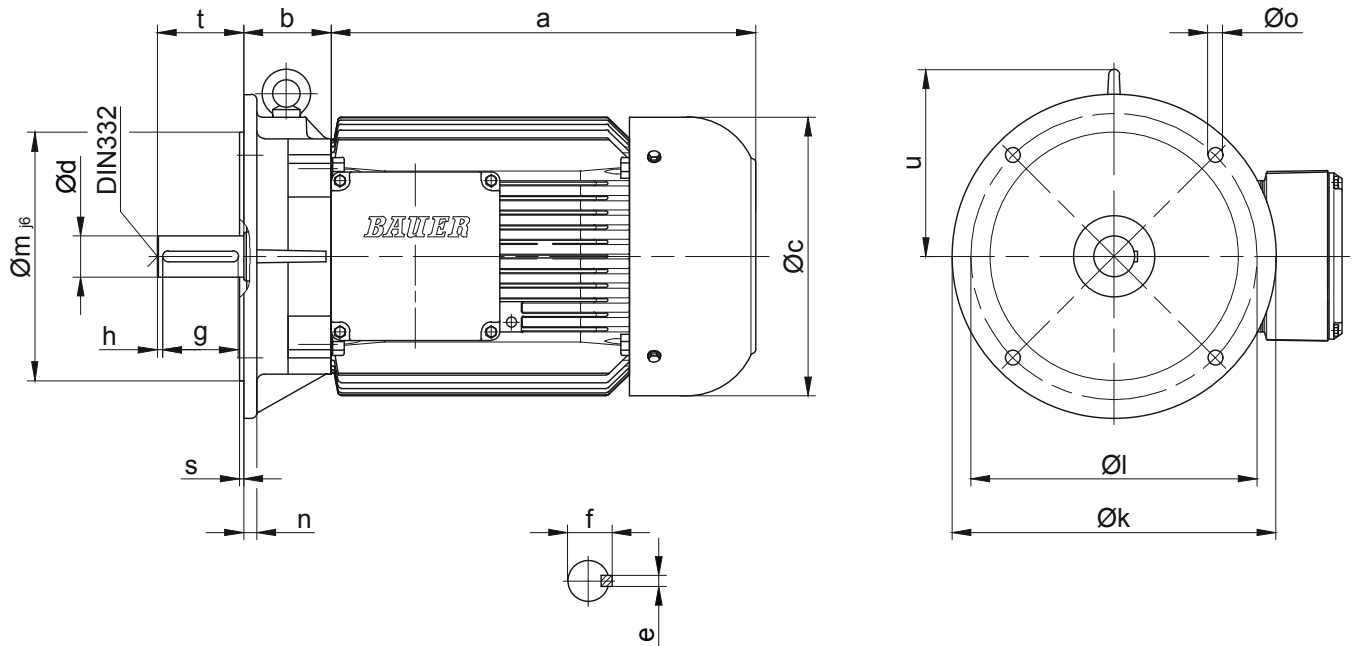

Motor		Dimensions (mm)																Centering
ASM	PMSM	a	b	c	d	e	f	g	h	k	l	m	n	o	s	t	u	DIN 332
D..06..	S..06..	170	45	123	11 <sub>j6</sub>	4	12.5	18	2.5	140	115	95	9	10	2.75	23	-	D4
D..07..	-	190	45	123	11 <sub>j6</sub>	4	12.5	18	2.5	140	115	95	9	10	2.75	23	-	D4
D..08..	S..08..	200	49	156	19 <sub>j6</sub>	6	21.5	35	2.5	200	165	130	10	12	3.5	40	-	D4
D..09..	S..09..	251	66	176	24 <sub>j6</sub>	8	27	40	5	200	165	130	10	12	3.5	50	128.5	D6
D..11..	S..11..	319	75	218	28 <sub>j6</sub>	8	31	50	5	250	215	180	11	14.5	4	60	145.5	D10

10

The actual gearbox design can vary from the geometry shown. Generate drive specific 3D and 2D geometries under [www.BauerCat.com](http://www.BauerCat.com).

# Energy Efficient Geared Motors

## Electric overhead conveyors series BM

---



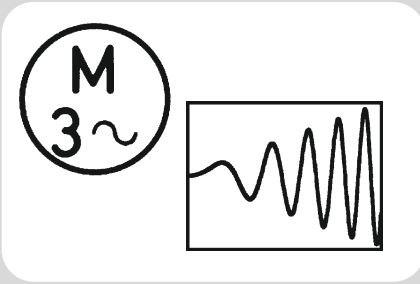

### Motors - ASM

<b>General</b> .....	<b>143</b>
ErP Directive 2009/125/EC .....	143
Regulation (EU) 2019/1781 .....	144
Torques .....	146
Line voltages .....	146
Line frequencies .....	147
Rating plate .....	147
Terminal box .....	147
Motor connections .....	148
Terminal connections for single speed motors without motor protection .....	149
Terminal connections for single speed motors with motor protection .....	150
Terminal connections for pole changing motors in Dahlander connection ( $\Delta/\text{YY}$ or $\text{Y}/\text{YY}$ ) .....	151
Terminal connections for pole changing motors with two separate windings ( $\text{Y}/\text{Y}$ or $\Delta/\Delta$ ) .....	152
Plug-and-socket connection .....	153
Motor protection .....	154
Thermistors (PTC) .....	154
Thermostatic protection .....	155
KTY sensors .....	156
PT100 sensors .....	157
Insulation .....	158
IP – Protection classes .....	158
Degrees of protection provided by enclosures for electrical equipment .....	158
Speed of output shaft .....	159
<b>Duty types as defined by EN 60034</b> .....	<b>160</b>
General .....	160
Continuous running duty (S1) .....	160
Short-time duty (S2) .....	160
Intermittent periodic duty (S3) .....	161
Intermittent periodic duty with starting (S4) .....	162
Intermittent periodic duty with electric braking (S5) .....	163
Continuous-operation periodic duty (S6) .....	164
Continuous-operation periodic duty with electric braking (S7) .....	164
Continuous-operation periodic duty with relative load/speed changes (S8) .....	165
Duty with non-periodic load and speed variations (S9) .....	165
Duty with discreet constant loads and speeds (S10) .....	166
<b>Operation with frequency converter</b> .....	<b>167</b>
Notes on design .....	167
Increased torque with reduced duty factor .....	167
Increased torque with external fan .....	167
Energy-saving function .....	168
Regeneration .....	168
Notes on operation with other-make frequency inverters .....	168
<b>Technical data</b> .....	<b>169</b>
<b>Technical data of the 50 Hz motors</b> .....	<b>169</b>
4-pole IE1 motors for continuous operation S1, line frequency 50 Hz .....	169
4-pole IE2 motors for continuous operation S1, line frequency 50 Hz .....	170
4-pole IE2 motors for continuous operation S1, mains frequency 50 Hz .....	171
4-pole IE3 motors for continuous operation S1, line frequency 50 Hz .....	172 ▶

# Energy Efficient Geared Motors

## Electric overhead conveyors series BM

4-pole IE3 motors for continuous operation S1, mains frequency 50 Hz.....	173
4 pole motors for periodic duty S3/S6-75 %, Mains Frequency 50 Hz.....	174
4 pole motors for periodic duty S3/S6, Mains Frequency 50 Hz .....	175
4/2-pole $\Delta$ /YY motors for continuous running duty (S1) and 50 Hz mains frequency .....	176
8/4-pole $\Delta$ /YY motors for continuous running duty (S1) and 50 Hz mains frequency .....	177
8/2-pole Y/Y motors for intermittent periodic duty S3 25/75 % and 50 Hz mains frequency .....	178
12/2-pole Y/Y motors for intermittent periodic duty S3 25/75 % and 50 Hz mains frequency .....	179
<b>Technical data of the 60 Hz motors.....</b>	<b>180</b>
4-pole IE1 motors for continuous operation S1, mains frequency 60 Hz.....	180
4-pole IE2 motors for continuous operation S1, mains frequency 60 Hz.....	181
4-pole IE2 motors for continuous operation S1, mains frequency 60 Hz.....	182
4-pole IE3 motors for continuous operation S1, line frequency 60 Hz.....	183
4-pole IE3 motors for continuous operation S1, mains frequency 60 Hz.....	184
4-pole motors for intermittent periodic duty (S3/S6 75 %) and 60 Hz mains frequency.....	185
4-pole motors for intermittent periodic duty (S3/S6) and 60 Hz mains frequency.....	186
4/2-pole motors $\Delta$ /YY for continuous operation S1, line frequency 60 Hz.....	187
8/4-pole motors $\Delta$ /YY for continuous operation S1, line frequency 60 Hz.....	188
8/2-pole Y/Y motors for intermittent periodic duty S3 25/75 % and 60 Hz mains frequency.....	189
12/2-pole motors Y/Y for intermittent periodic duty S3-25/75 %, line frequency 60 Hz.....	190
<b>Operation with frequency converter, 50 Hz .....</b>	<b>191</b>
IE1 Motor torques for frequency-converter range 5 Hz - 70 Hz, line frequency 50 Hz .....	191
IE1 Motor torques for frequency-converter range 5 Hz - 100 Hz, line frequency 50 Hz .....	192
IE2 Motor torques for frequency-converter range 5 Hz - 70 Hz, line frequency 50 Hz .....	193
IE2 Motor torques for frequency-converter range 5 Hz - 100 Hz, line frequency 50 Hz .....	194
IE3 Motor torques for frequency-converter range 5 Hz - 70 Hz, line frequency 50 Hz .....	195
IE3 Motor torques for frequency-converter range 5 Hz - 100 Hz, line frequency 50 Hz .....	196
<b>Operation with frequency converter, 60 Hz .....</b>	<b>197</b>
IE1 Motor torques for frequency-converter range 6 Hz - 84 Hz, line frequency 60 Hz .....	197
IE1 Motor torques for frequency-converter range 6 Hz - 120 Hz, line frequency 60 Hz .....	198
IE2 Motor torques for frequency-converter range 5 Hz - 80 Hz, line frequency 60 Hz .....	199
IE2 Motor torques for frequency-converter range 5 Hz - 120 Hz, line frequency 60 Hz .....	200
IE3 Motor torques for frequency-converter range 5 Hz - 80 Hz, line frequency 60 Hz .....	201
IE3 Motor torques for frequency-converter range 5 Hz - 120 Hz, line frequency 60 Hz .....	202

### ErP Directive 2009/125/EC

Directive 2009/125/EC of the European Parliament and the Council, issued in 2009, specifies requirements for the environmentally responsible design of energy-related products (ErPs). In November 2009 it superseded Directive 2005/32/EC, which formed the framework for requirements for the environmentally responsible design of energy-using products (EuPs). This change has no effect on already proclaimed implementation measures.

#### Objectives

The ErP Directive has several objectives:

##### 1. Mitigating the environmental impact of energy-using products

This objective is intended to be achieved by the documentation and labelling of products, by regulations for inspection, and by the formulation of individual requirements in implementation measures. As the entire product life cycle is taken into consideration, action must be taken as early as the design phase.

##### 2. Climate protection

Achievement of the EU climate protection objectives is to be supported. This can be implemented by reducing energy consumption and the emission of global warming gasses in the production, operation and disposal of energy-using products.

##### 3. Harmonised legislation

The directive creates a framework for the European regulation of environmental design requirements. This avoids trade impediments resulting from differences in national regulations. This can be achieved by means of the proclamation of legally binding implementation measures for the entire Community and protection of free trade in goods against further-reaching regulations of the Member States.

### Regulation (EU) 2019/1781

To establish eco-design requirements for electric motors and variable speed drives pursuant to Directive 2009/125/EC

#### Valid from: 01.07.2021

- Frequency converter 0.12 - 1,000 kW: IE2
- 3-phase motors 0.12 < 0.75 kW/2.4, 6 or 8 poles: IE2 (Excluded: Ex eb (DXE))
- 3-phase motors 0.75 - 1,000 kW/2.4, 6 or 8 poles: IE3 (Excluded: Ex eb (DXE))

#### ATTENTION:

Brake motors are no longer exempt!!  
IE2 for inverter operation is no longer permitted!!!

#### Valid from: 01.07.2023

- 1-phase motors  $\geq 0.12$  kW: IE2
- Ex eb (DXE) Motors  $\geq 0.12$  kW: IE2
- 3-phase motors 75 kW – 200 kW 2, 4 or 6 pole: IE4  
(Exempt: brake motor and all explosion-proof motors)

#### Scope

Induction electric motors without brushes, commutators, slip rings or electrical connections to the rotor, rated for operation on a 50 Hz, 60 Hz or 50/60 Hz sinusoidal voltage and having the following characteristics:

- 2-, 4-, 6- and 8-pole motors
- Rated power PN between 0.12 kW and 1000 kW
- Rated voltage UN over 50 V up to and including 1,000 V
- are designed for continuous operation (S1, S3  $\geq 80$  % ED, S6  $\geq 80$  % ED) and are intended for direct mains operation

### Which engines are excluded from the scheme?

- Motors designed to be operated completely immersed in a liquid
- Motors fully integrated into a product (e.g. a gearbox, a pump, a fan or a compressor) whose energy efficiency cannot be measured independently of that product
- Motors with integrated frequency converter (compact drives) whose energy efficiency cannot be tested independently of the frequency converter
- Motors specifically designed and specified to operate exclusively
  - at altitudes exceeding 4000 m above sea-level
  - at ambient temperatures above 60 °C
  - at ambient temperatures below -30 °C
- Motors with integrated brake, which is an integral part of the inner motor construction and cannot be removed or supplied from a separate power source when testing the motor efficiency.
- Motors specifically qualified for the safety of nuclear installations, as defined in Article 3 of Council Directive 2009/71/EURATOM
- Motors with mechanical commutators
- Totally enclosed Non-Ventilated motors (TENV)
- Engines from the respective scope of application of the two deadlines 01.07.2021 or 01.07.2023, which were placed on the market before these deadlines, may continue to be placed on the market until 30.06.2029 as 1:1 replacements and may be specifically marketed as such
- Multi-speed motors, i.e. pole-changing motors
- Motors designed specifically for the traction of electric vehicles
- Motors in portable equipment whose weight is supported by hand during operation
- Motors in hand-held mobile equipment which are moved during operation
- Motors in cordless or battery-operated equipment
- Motors for underground mining (mines)

### Method for determining the motor efficiency according to IEC 60034-2-1

Individual loss procedure

Additional losses according to residual loss method

Low measurement uncertainty

Bauer geared motors for connection to three-phase supply are supplied with specially designed induction motors. This design ensures maximum operating safety with high breakaway torque and minimum starting current.

The torque/speed characteristic is largely free of torque dips. Torque is optimised to suit requirements and application parameters. See "www.bauergears.com" for more information.

### Torques

The torques as stated in the selection tables are fully available at the output shaft. These figures apply for continuous operation (S1-100 %) at a maximum ambient temperature of 40 °C and at site elevations up to 1000 m above sea level. Drives for higher ambient temperatures and site elevations are available on request. Gear efficiencies, which are lower than the usual values for spur gears, are taken into account in the torques listed in the selection tables.

### Line voltages

BAUER motors are available as standard for the following three-phase line voltages:

Motor size	Standard voltages:
D..04LA4 - D..09X,4	220 V Δ / 380 V Y 50 Hz
0.06 - 2.2 kW	230 V Δ / <b>400 V Y 50 Hz*</b>
	240 V Δ / 415 V Y 50 Hz**
	440 V Y / 60 Hz 460 V Y/60 Hz
from D..11SA4	220 V Δ / 380 V Y 50 Hz
from 3.0 kW	230 V Δ / 400 V Y 50 Hz
	240 V Δ / 415 V Y 50 Hz**
	440 V Y / 60 Hz 460 V Y/60 Hz
	380 V Δ / 660 V Y 50 Hz
	<b>400 V Δ / 690 V Y 50 Hz*</b>
	415 V Δ / 50 Hz**
	440 V Δ / 60 Hz
	460 V Δ / 60 Hz

\*Voltage recommended world-wide by IEC 38 and in Europe by CENELEC.

\*\*= Insulation Class F is necessary.

Designs for other voltages available on request and at extra cost.

Unless otherwise specified, motors for operation in conjunction with frequency converters with a 50 or 60 Hz frequency have a Y-circuit to optimise operating noise and winding load.

Unless otherwise stated, the tolerance for the rated voltage is +/- 5 %, in accordance with IEC 60034-1.

The D..04.. to D..18.. motors in 4 pole design can be operated within a tolerance of +/- 10 % of the rated voltage (400 V 50 Hz).

### Line frequencies

All motors are available with the same power ratings for either 50 or 60 Hz. Increased power models are available on request.

### Rating plate

Bauer geared motors are supplied with a corrosion-proof rating plate as standard. The standard rating plate is made of special plastic tried and tested in many years of practical use and approved for hazardous areas by the Physikalisch-Technische-Bundesanstalt (PTB).

<b>BAUER</b>		73734 Esslingen Made in Germany	
3-Mot.-No. E 11873812-1	A/ 188W573	40/2022	
Type <b>BM30-61UO/D08MA4-TF-ST-S/E008B6HN/</b>			
<b>TM</b>			
0,55 kW	cosφ 0,75	S1	IsoCl. F
50 Hz	Y	400 V	1,6 A
n <sub>1</sub> 1400	n <sub>2</sub> 28,5 r/min	i 49,66	143 Nm
20-50-60 Hz	186-400-400 V	0,21-0,47-0,57 kW	
B34001123803	FU	100 %	
IM H1	IP 65	1,2 L	PGLP 460
t <sub>amb</sub> -20...40 °C			49,4 kg
180 V DC	0,15 A	6,5 Nm	380...420 V AC 0,11 A
CE		SCH01	EN60034

### Terminal box

The cables of motors with and without brakes can be introduced into the motor terminal box from side A or side C.

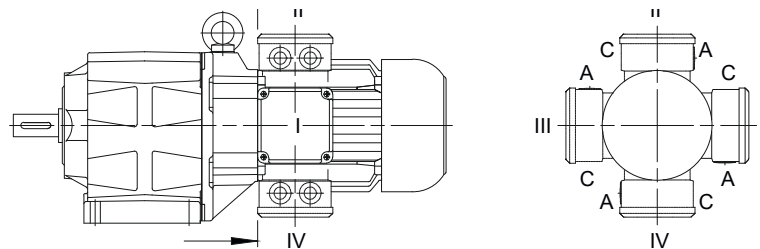

The standard position for the motor terminal box is shown in the dimensional drawings for the geared motors (see chapter 10,11,12 and 13). The terminal box can be installed at any of 3 other positions on request, if on-site space is restricted. The 4 possible positions are 90° offsets around the axis of the motor (dimensional drawing and designation for standard terminal box, see chapter 16 "Dimensional drawing standard terminal box").

Cast-on terminal boxes (KAG) are supplied with knock out entries with metric nut for cable gland. Screw- on terminal boxes (TBI...4 are supplied with a metric screw thread as standard.

### Motor connections

The electrical connection of gear motors is time consuming and creates costs, which cannot be neglected both during initial installation and in service cases. These costs are reduced considerably by the use of BAUER Gear Motors, have CAGE CLAMP® connection technology instead of the conventional terminal block – and that without extra charge.

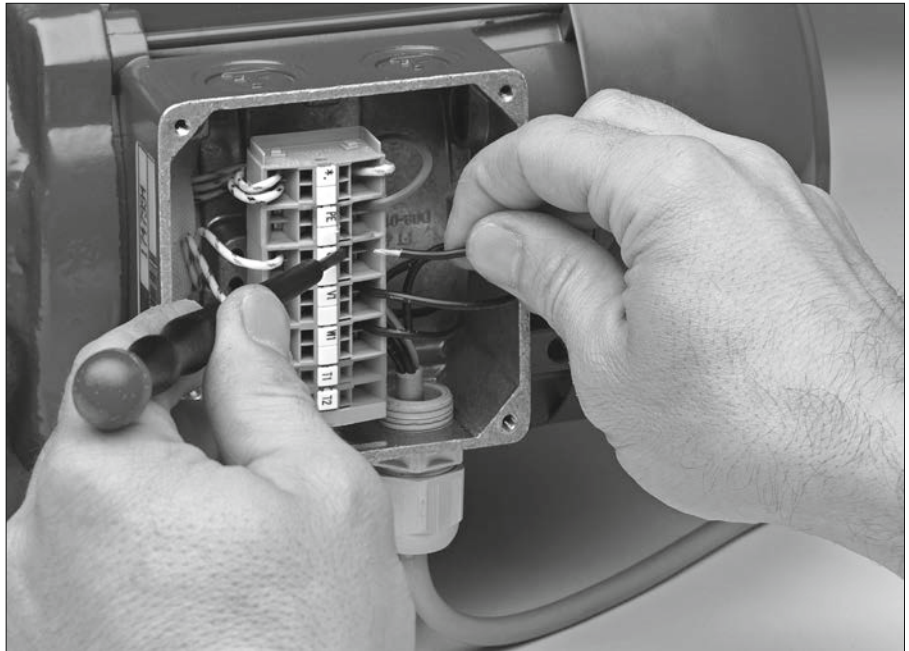

### What are the advantages for you ?

#### Cost reduction during connection

Public timing test have confirmed, that the electrical connection of a cable by means of CAGE CLAMP® technology saves up to 75 % working time compared with the classic screw connection.

#### Simple Handling

Cable connection from the top, very easily accessible: The CAGE CLAMP® spring is pressed, and the cable inserted from the front, i.e. in the field of vision of the installation engineer.

#### Which cable core diameters ?

Suitable for all copper wires from 0,5 mm<sup>2</sup> to 25 mm<sup>2</sup>.

#### Cost saving in material and tooling

- multicore cable ends, cable eyes or cable ring eyes are no longer needed
- Tools such as crimping pliers are no longer needed
- Inadvertently over tightening or breaking of the terminal bolts and the procurement of a new terminal block belong in the past.
- Searching and procurement of nuts and washers for the terminal blocks, which have fallen down, also belongs in the past.

#### Vibration and shock resistant

Vibration and shock result neither in conductor damage nor in a measurable contact interruption. The connection is service free.

#### Type of conductors

The CAGE CLAMP®-connector can clamp fine stranded, stranded and solid cores wires.



### Terminal connections for single speed motors without motor protection

Standard connection of three phase motors without motor protection via CAGE CLAMP®.  
D..04.. - D..09..

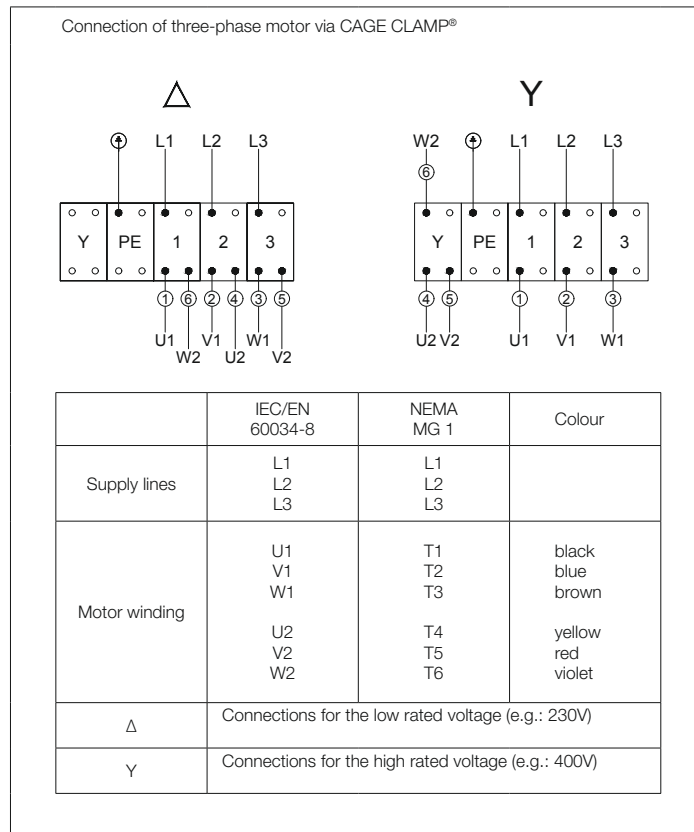

D..11.. - D..18..

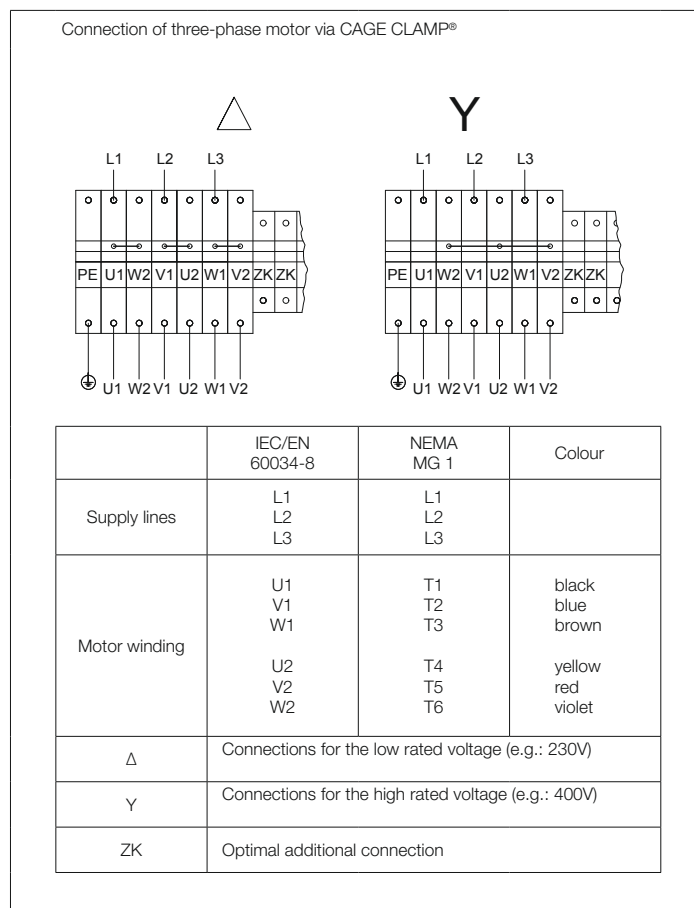

### Terminal connections for single speed motors with motor protection

Standard connection of three phase motors with motor protection via CAGE CLAMP®.  
D..04.. - D..09..

Connection of three-phase motor and thermal motor protection via CAGE CLAMP®

	IEC/EN 60034-8	NEMA MG 1	Colour
Supply lines	L1 L2 L3	L1 L2 L3	
Motor winding	U1 V1 W1  U2 V2 W2	T1 T2 T3  T4 T5 T6	black blue brown  yellow red violet
Δ	Schaltung für niedrige Nennspannung (z. B.: 230V)		
Y	Schaltung für hohe Nennspannung (z. B.: 400V)		
T1 T2	Thermal motor protection		

D..11 - D..18

Connection of three-phase motor via CAGE CLAMP®

	IEC/EN 60034-8	NEMA MG 1	Colour
Supply lines	L1 L2 L3	L1 L2 L3	
Motor winding	U1 V1 W1  U2 V2 W2	T1 T2 T3  T4 T5 T6	black blue brown  yellow red violet
Δ	Connections for the low rated voltage (e.g.: 230V)		
Y	Connections for the high rated voltage (e.g.: 400V)		
ZK	Optimal additional connection		

### Terminal connections for pole changing motors in Dahlander connection ( $\Delta/YY$ or $Y/YY$ )

Standard connection of three phase motors without motor protection via CAGE CLAMP®.  
D..04..-D..09.. - S..04..-S..09..

Motor 2 Speeds, Dahlander connection  $\Delta/YY$  or  $Y/YY$   
(T1-T2 Thermal Motor protection optional)

	IEC/EN 60034-8	NEMA MG 1	Colour
Supply lines	L1 L2 L3	L1 L2 L3	
Motor winding	1U 1V 1W  2U 2V 2W	T1 T2 T3  T5 T6 T4	black blue brown  yellow red violet
I	low speed		
II	high speed		

D..11.. - S..11..

Connection of three phase motor via CAGE CLAMP®  
Pole changing for 2 speeds; Dahlander connection  $\Delta/YY$

	IEC/EN 60034-8	NEMA MG 1	Colour
Supply lines	L1 L2 L3	L1 L2 L3	
Motor winding	1U 1V 1W  2U 2V 2W	T1 T2 T3  T4 T5 T6	black blue brown  yellow red violet
I	low speed		
II	high speed		
ZK	Optimal additional connection		
*	Star point over Dahlander Relay		

11

### Terminal connections for pole changing motors with two separate windings (Y/Y or Δ/Δ)

Standard connection of three phase motors with motor protection via CAGE CLAMP®.

D..04.. - D..09..., S..04..-S09..

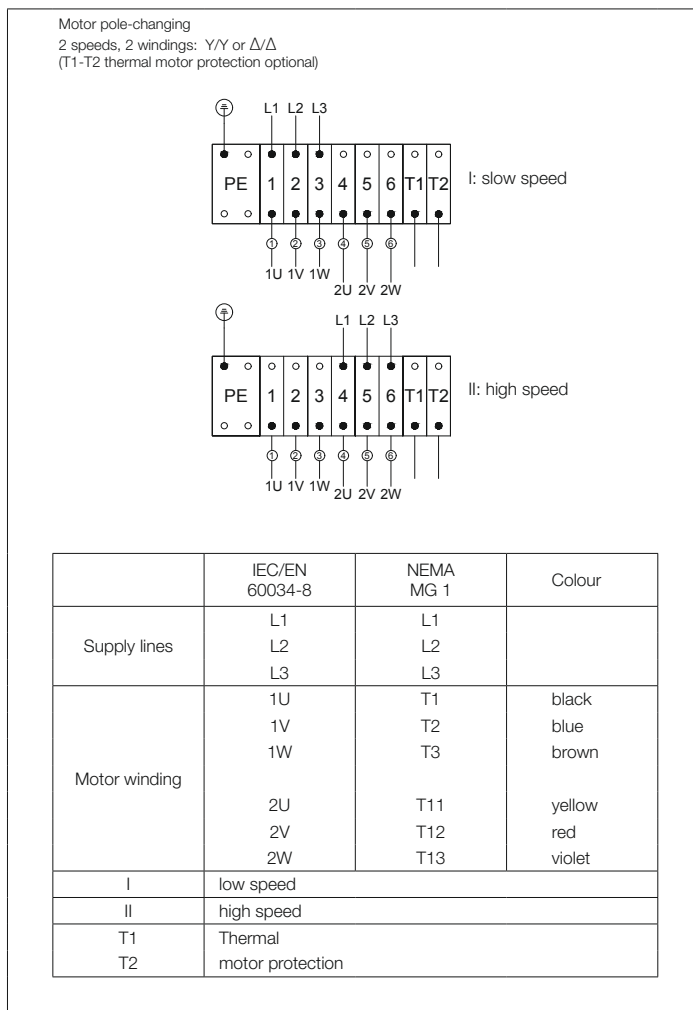

D..11.. - S11..

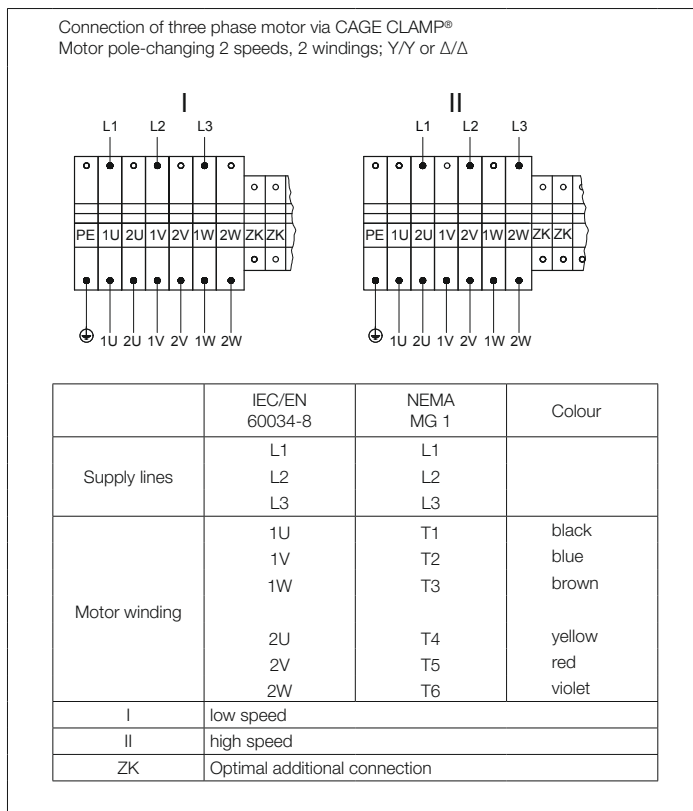

### Plug-and-socket connection

D..06.. to D..16.. Bauer motors are available with plug-in motor connection. The socket housing is mounted on the fan-cowl side of the terminal box as standard. This layout minimises the protrusion caused by the plug.

The standard plug-and-socket type connection incorporates the attachment housing, pin insert and cover. Grommet-type housings and jack inserts are available on request at extra cost. Pin assignments on request (dimensional drawing, see chapter 17 "Dimensional drawing, plug-connector terminal box").



A design with single clamp lever according to the DESINA regulation of the „Verbandes Deutscher Werkzeugmaschinenhersteller“ (VDW) is also available.

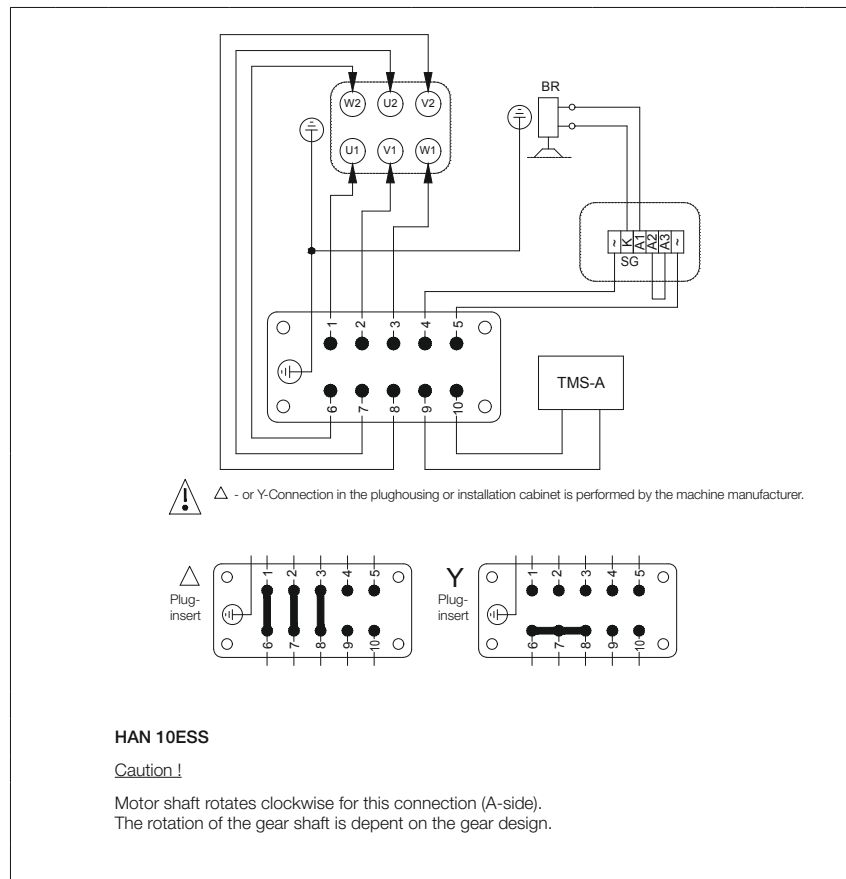

The motors are also available with a low-cost round plug connector as an alternative. This is fitted at the factory in the standard terminal box and is also suitable for brake connection, thermistors and thermostats. Additional information on request.

Bauer motors from D..08.. with motor-mounted brake are also available with plug-in brake connection. This means that if it requires attention, the brake can be replaced on site with no loss of time.

### Motor protection

Each geared motor requires a current-dependent motor protection switch or an overcurrent relay with thermal delay in the switchgear to protect the motor windings. The rated motor currents required for settings are stated in the order acknowledgment. Thermal protection for the winding is recommended as an additional safety measure for special operating conditions (short-time or intermittent periodic duty, high switching frequency, severe voltage fluctuations or restricted cooling) and for operation in conjunction with a frequency converter.

### Thermistors (PTC)

Thermistors are temperature-dependent resistors which are fitted in each phase winding. In conjunction with a motor protection switch, they ensure optimum protection for the winding in the event of rapid temperature rise. Characteristic to DIN 44081 and "Mark A" to IEC 34-11-2. Thermistors are available for all motors at extra cost. The requisite monitoring device is not included in the scope of supply.

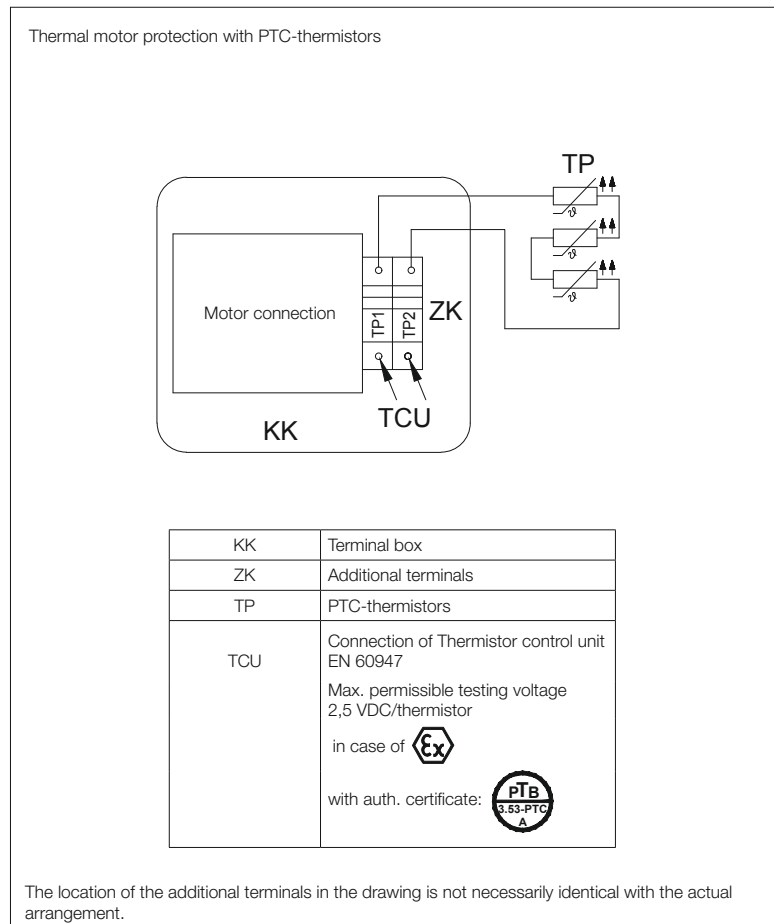

### Thermostatic protection

Bimetal switches are used for slow-acting, independent temperature monitoring and are embedded in each winding section of the motor.

The bimetal disc is sized such that when the temperature rises above a specific, previously set value, the disc suddenly snaps from a convex state to a concave state and the contact moves vertically away from the contact plate. In this state the switch is either open (normally closed switch) or closed (normally open switch). A significant temperature change is necessary to allow the bimetal disc to independently snap back to its initial position. When it does, the switch is again closed (normally closed switch) or open (normally open switch). Thermal protection switches are available for all motors at additional cost. For technical reasons, this option is not recommended for large motors (D..11.. to D..18..).

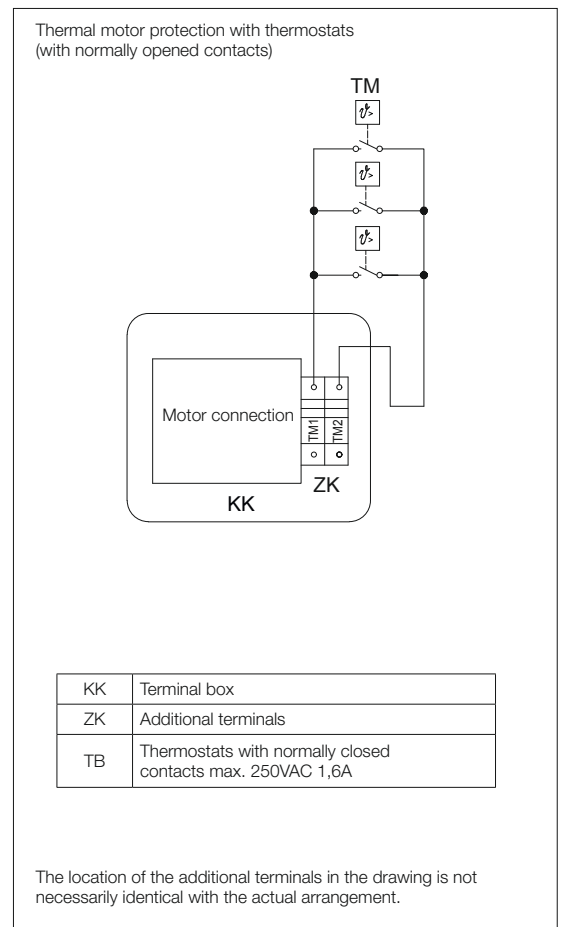
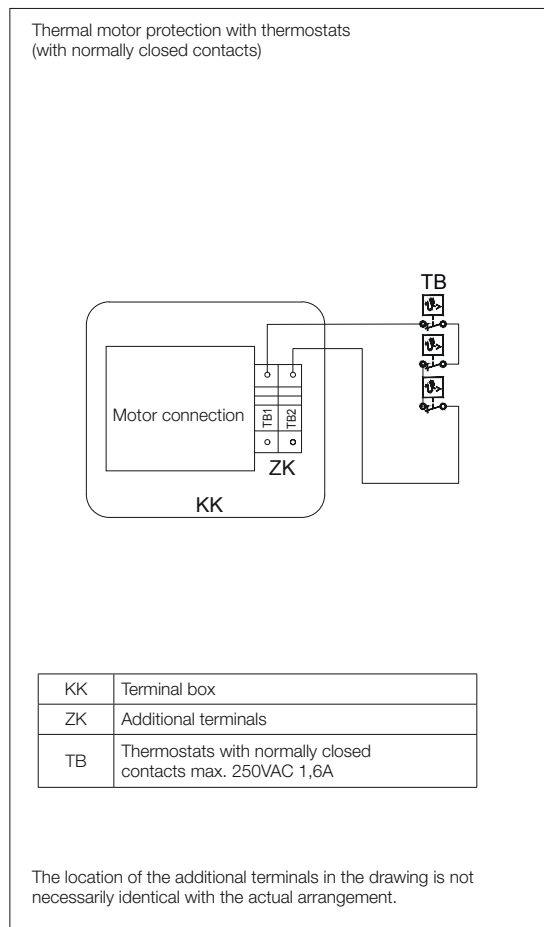

### KTY sensors

KTY sensors with heat-shrink insulation can be used to measure and monitor critical surface temperatures and internal temperatures of motors and machines. These sensors are suitable for use in harsh industrial environments in all places where accurate measurements with a single sensor are required. KTY sensors are available for all types of motors at additional cost.

Working principle: KTY sensors are temperature-dependent components. The resistance of the KTY sensor increases when its temperature rises. The characteristic curve is nearly linear in the sensor's measuring range; the reference resistance (at 100 °C) is 970 to 1030 ohms.

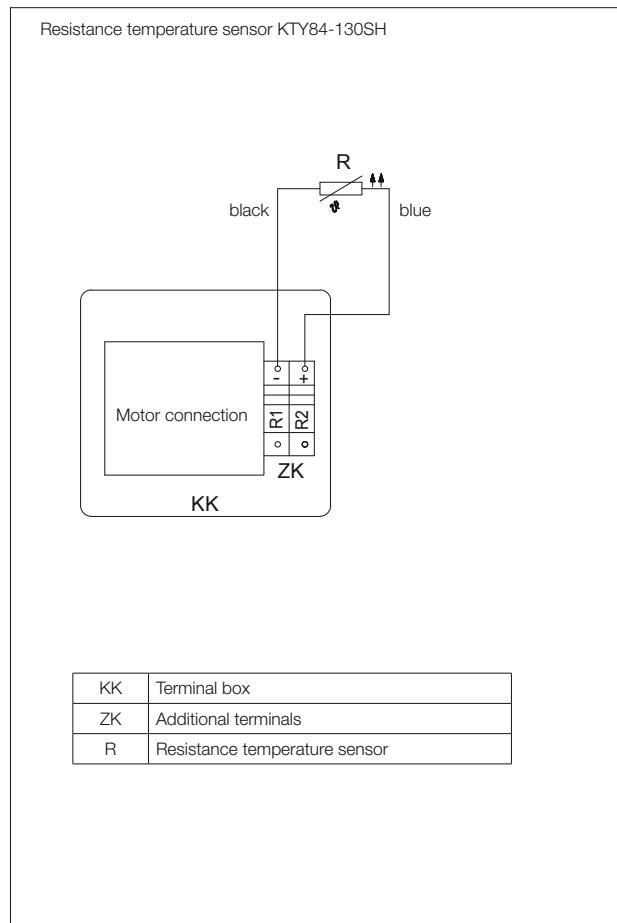



### PT100 sensors

Precise monitoring of motor temperatures is necessary in many fields of industry. Pt100 sensors feature high accuracy, short response time and long-term stability, and they are suitable for use over a wide range of temperatures. Pt100 sensors are available for all motor types at additional cost.

#### Specifications

Nominal resistance: 100  $\Omega$  at 0 °C

The resistance characteristics are specified in EN 60751.

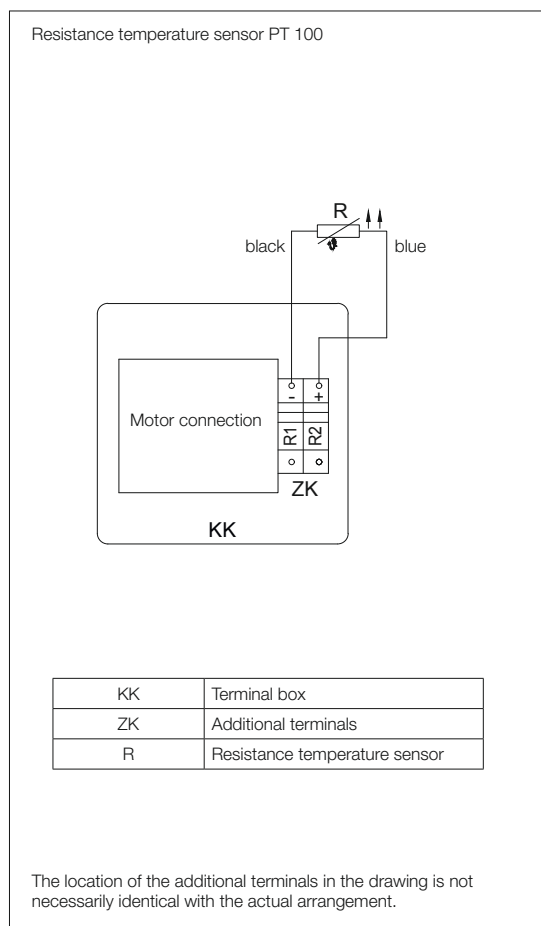

### Insulation

The gearmotors described in the selection tables of this catalogue with the motor sizes D..04., D..05., D..06., D..08., D..09S and D..09L are executed in insulation class B. Temperature class F is available on request at extra cost.







4-pole motors D..07.. and D..09XA4 (2.2 kW) to D..18XA4 (30 kW) and all multi-speed motors are rated in Temperature Class F as standard.

Insulation Class F bestows the winding a multiple protection against high humidity, acidic gases and heavy tropical influences while making the same shock resistant and more resistant to heat. Protection against insects (termites) is guaranteed through the complete enclosure (IP65) as long as the mains cables are encased in metal.

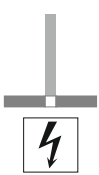
### IP – Protection classes

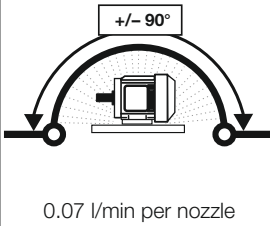
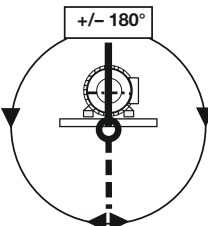
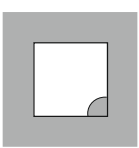
Bauer motors from motor size D..06.. are manufactured to IP65 degree of protection as standard. Motor sizes D04 and D05 have a smooth motor housing of IP54. Higher IP protection classes on request.

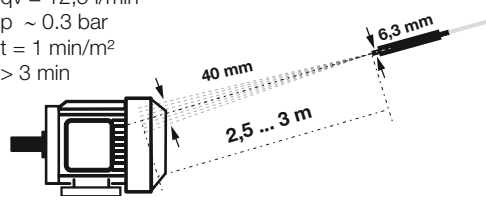
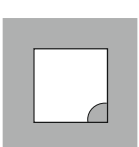
### Degrees of protection provided by enclosures for electrical equipment

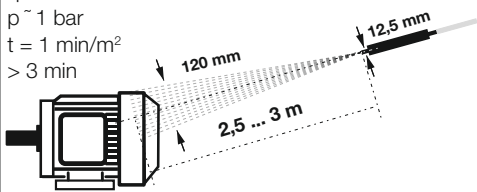
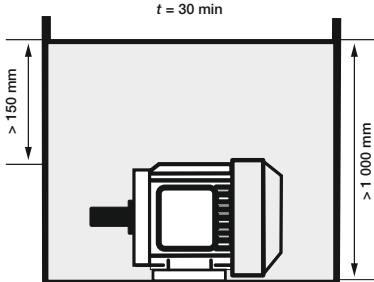
First IP - code number after DIN EN 60529				Second IP - code number after DIN EN 60529			
Protection against penetration of solid foreign bodies		Protection of persons against access to hazardous parts with		Protection against penetration of moisture or water			
4	diameter $\geq 1.0$ mm			4	Splash water		
5	Dustproof		Wire 	5	Jet water		
6	Dust tight			6	Strong Jet water		
				7	Temporary Submerge		

11

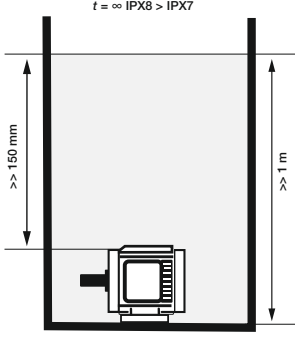
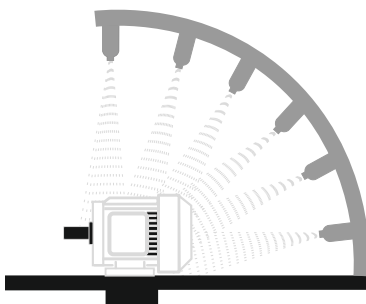
First IP - code number after DIN EN 60529		Second IP - code number after DIN EN 60529	
Protection against penetration of solid foreign bodies	Protection of persons against access to hazardous parts with	Protection against penetration of moisture or water	
		8	Permanent Submerge  <p><math>t = \infty</math> IPX8 &gt; IPX7</p> <p>&gt;&gt; 150 mm</p> <p>E</p> <p>x = 5 m (Standard) or by agreement</p>
		6 (9K = DIN 40050-9)	High pressure and high jet water temperature  <p>Housing <math>\geq 250</math> mm</p> <p><math>t = 1 \text{ min /m}^2</math> <math>&gt; 3 \text{ min}</math></p> <p>Water temperature <math>(80 \pm 5) \text{ }^\circ\text{C}</math></p> <p>15 l/min, 100 bar</p> <p>Distance <math>(175 \pm 25) \text{ mm}</math></p>

### Speed of output shaft

The rated speeds in the selection tables are guidelines for load at rated power. Speed can vary depending on degree of load and temperature (particularly in the case of relatively small motors). Combination gear units for lower speeds are available on request.

### General

Aside from special drives (such as lifting equipment), standard motors are always designed for continuous running duty. If the drive is operated with frequent on/off cycles, it may be necessary to select a larger motor with a special design. On the other hand, with pronounced short-time duty it is often possible to select a smaller model. **For this reason, it is technically necessary or economically advantageous to inform the motor manufacturer of any duty type that differs from continuous running.**

### Continuous running duty (S1)

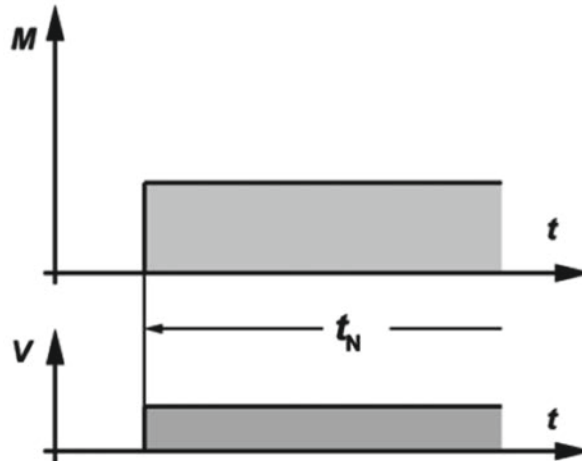

Operation under rated load for sufficient time to allow temperature equilibrium to be attained, such that the temperature does not increase any more with continued operation. The equipment can operate continuously under the rated load without exceeding the allowable temperature.

### Short-time duty (S2)

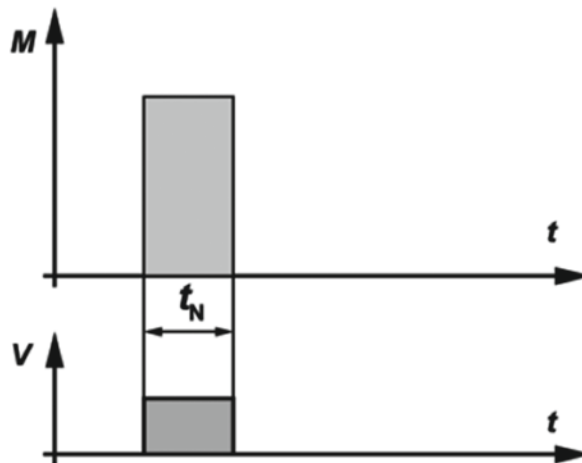

The operating time under rated load is short compared with the subsequent rest period. The standard operating times are 10, 30, 60 and 90 minutes. The equipment can operate for this period under the rated load without exceeding the allowable temperature.

Example: S2 – 60 min

## Intermittent periodic duty (S3)

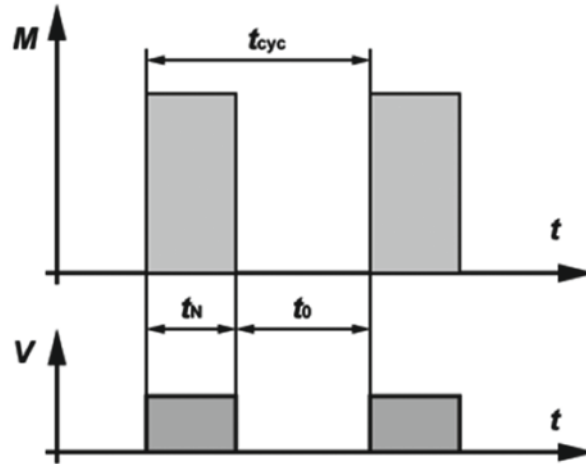

S3 duty consists of a sequence of identical cycles, each composed of an operating time with constant load and a rest time with the windings de-energised. The cycle is such that the starting current does not significantly affect the temperature rise. The operating time under rated load and the subsequent pause are both short. The equipment can operate under load only during the period indicated by the duty cycle as a percentage of the total cycle time (cycle duration).

The standardised duty cycles are 15, 25, 40 and 60 %. The cycle duration is 10 minutes unless otherwise specified.

Intermittent periodic duty means that a state of thermal equilibrium is not reached during the load interval.

The duty cycle can be determined as follows:

$$ED = \frac{t_N}{t_{cyc}} \times 100\% = \frac{t_N}{t_N + t_0} \times 100\%$$

Example: S3 – 25%

### Intermittent periodic duty with starting (S4)

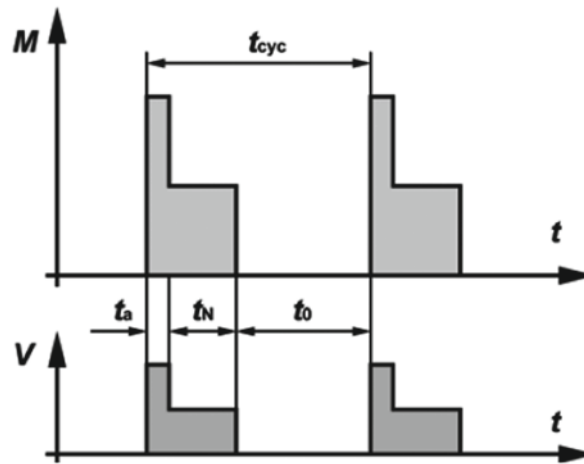

S4 duty consists of a sequence of identical cycles, each of which is composed of a distinct starting time, a time of operation under constant load, and a rest period with the windings de-energised.

The operating time under rated load and the subsequent pause are both short. The equipment can operate under load only during the period indicated by the duty cycle as a percentage of the total cycle time (cycle duration).

The standardised duty cycles are 15, 20, 40 and 60 %. The cycle duration is 10 minutes unless otherwise specified.

The load cycle corresponds to mode S3, but with additional heating during the starting time that must be taken into account.

The duty cycle can be determined as follows:

$$ED = \frac{(t_a + t_N)}{t_{cyc}} \times 100\% = \frac{t_a + t_N}{t_a + t_N + t_o} \times 100\%$$

Example: S4 – 25 %,  $J_M = 0.15 \text{ kgm}^2$

## Intermittent periodic duty with electric braking (S5)

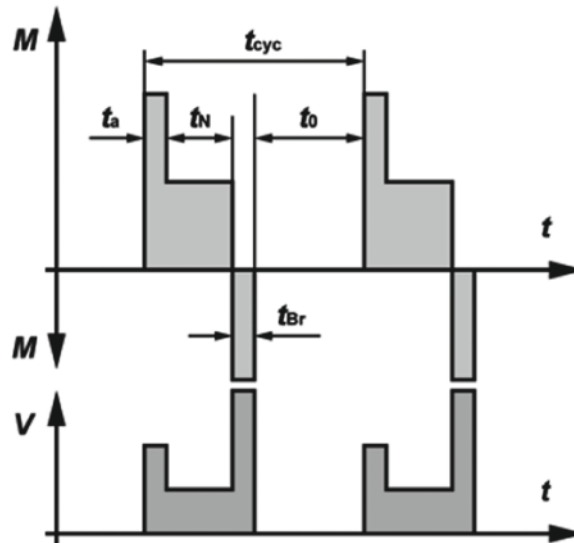

S5 duty consists of a sequence of identical cycles, each of which is composed of a starting time, a time of operation under constant load, a time of fast electric braking, and a rest period with the windings de-energised.

The operating time under rated load and the subsequent pause are both short. The equipment can operate under load only during the period indicated by the duty cycle as a percentage of the total cycle time (cycle duration).

The standardised duty cycles are 15, 20, 40 and 60 %. The cycle duration is 10 minutes unless otherwise specified.

The load cycle corresponds to S3 duty, but with additional warming during the starting time  $t_a$  and the braking time  $t_{Br}$  taken into account.

The duty cycle can be determined as follows:

$$ED = \frac{(t_a + t_N + t_{Br})}{t_{cyc}} \times 100\% = \frac{t_a + t_N + t_{Br}}{t_a + t_N + t_{Br} + t_0} \times 100\%$$

Example: S5 – 25%;  $J_M = 0.15 \text{ kgm}^2$ ,  $J_{ext} = 0.7 \text{ kgm}^2$   
 ( $J_M$  Moment of inertia of the motor /  $J_{ext}$  Moment of inertia of the load)

### Continuous-operation periodic duty (S6)

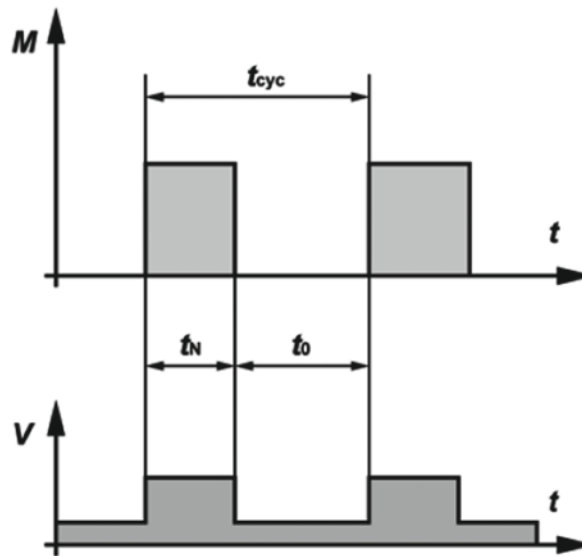

This type of duty corresponds to S3, with the exception that the equipment remains energised during the rest periods. In other words, it operates with no load during these periods. The duty cycle and cycle duration are specified the same way as for S3 duty.

The duty cycle can be determined as follows:

$$ED = \frac{t_N}{t_{cyc}} \times 100\% = \frac{t_N}{t_N + t_0} \times 100\%$$

Example: S6 – 40 %

### Continuous-operation periodic duty with electric braking (S7)

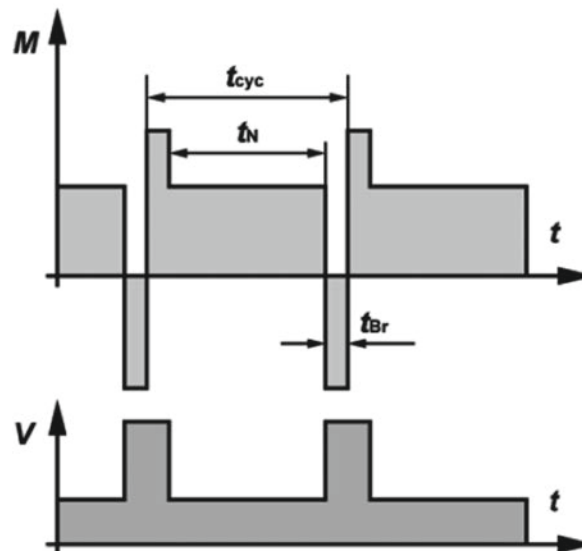

The machine starts up, operates under load, and then is braked electrically, for example by feeding it from a DC power source. Following this, it starts up again immediately. The machine can operate continuously in this manner if the specified moments of inertia of the motor  $J_M$  and of the load  $J_{Ext}$  as well as the specified duty cycle are not exceeded. If the cycle duration is not specified, it is assumed to be 10 minutes.

The duty cycle can be determined as follows:  $DC = 1$

Example: S7 –  $J_M = 0.4 \text{ kgm}^2$ ,  $J_{Ext} = 7.5 \text{ kgm}^2$   
( $J_M$  Moment of inertia of the motor /  $J_{Ext}$  Moment of inertia of the load)



### Continuous-operation periodic duty with relative load/speed changes (S8)

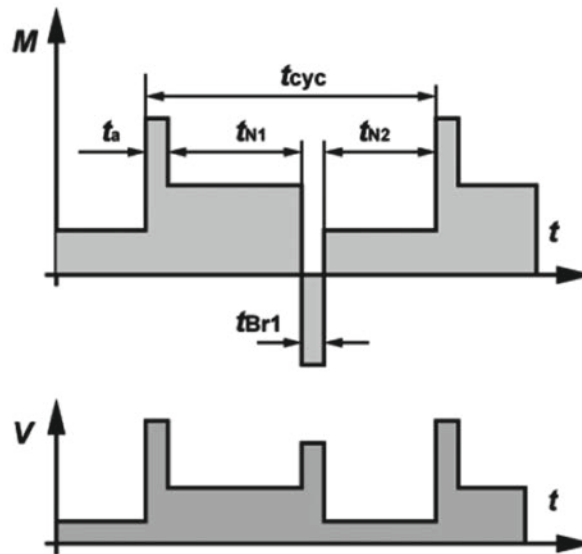

The machine runs continuously under variable load with frequent speed variations. The machine can operate continuously in this manner if at each speed the specified values are not exceeded (moments of inertia  $J_M$  and  $J_{Ext}$  cycle duration (if other than 10 minutes), rated output and duty cycle. With a moment of inertia of  $1 \text{ kg m}^2$ , the acceleration characteristics are the same as with a mass of  $1 \text{ kg}$  at a distance of  $1 \text{ m}$  from the axis of rotation).

The duty cycle can be determined as follows:

$$ED = \frac{t_a + t_{N1}}{t_{cyc}} \times 100\% = \frac{t_{Br} + t_{N2}}{t_{cyc}} \times 100\%$$

Example: S8 –  $J_M = 0.5 \text{ kgm}^2$ ,  $J_{Ext} = 6 \text{ kgm}^2$   
( $J_M$  Moment of inertia of the motor /  $J_{Ext}$  Moment of inertia of the load)

### Duty with non-periodic load and speed variations (S9)

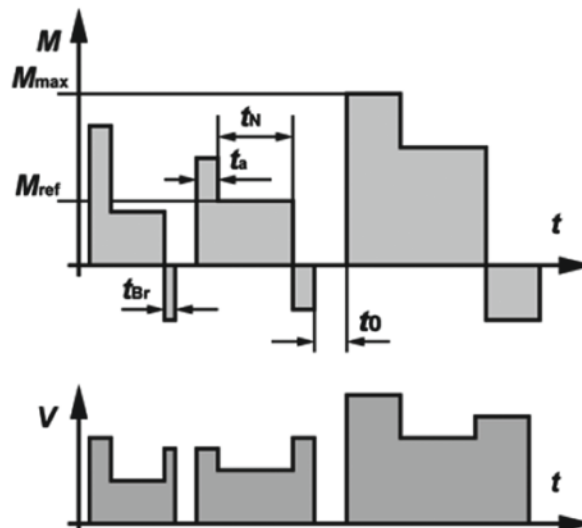

In S9 duty the load and the speed vary non-periodically within the permissible operating range. This includes frequently applied overloads, which must never exceed the reference load. For this duty type, a constant load appropriately selected and based on duty type S1 shall be taken as the reference value  $M_{ref}$  for the overload.

Duty with discreet constant loads and speeds (S10)

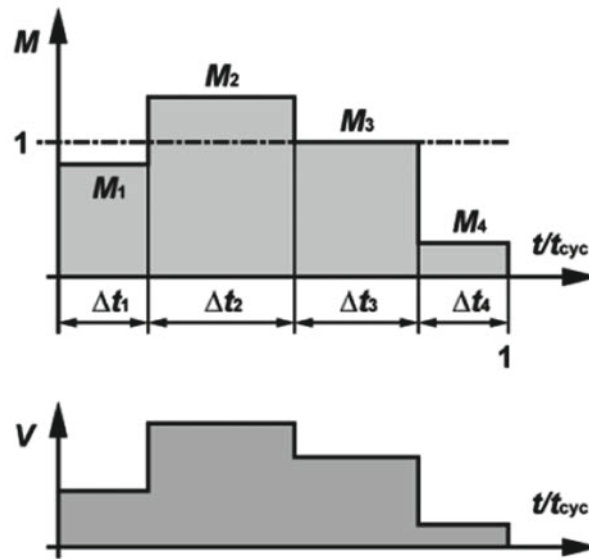

S10 duty comprises operation with at most four different load levels, each of which is maintained long enough to allow the machine to reach thermal equilibrium.

The minimum load within a duty cycle may have a value of zero (no-load operation or at rest with the windings de-energised).

The appropriate abbreviation is S10 followed by the per unit quantities  $p/\Delta t$  for the respective load and its duration and the per unit quantity  $TL$  for the relative thermal life expectancy of the insulation system. The reference value for the thermal life expectancy is the thermal life expectancy at rating for continuous running duty and permissible limits of temperature rise based on duty type S1. For a time de-energized and at rest, the load shall be indicated by the letter  $r$ .

Example: S10  $p/\Delta t = 1.1/0.4, 1/0.3, 0.9/0.2, r/0.1$ ;  $TL = 0.6$

The figures given in the table below are for Bauer motors operating in conjunction with the frequency inverter. The torques referred to in tables can be entered for the respective frequencies in continuous operation (S1 = duty factor 100 %).

#### Notes on design

Use the torque required at the lowest operating speed to select motors for applications which require constant torque over the entire speed range, as is the case, for example, with lifting gear and conveyors. Bear in mind, too, the possibility of torque being lower in the field-weakening range.

Use only the torque required at the highest operating speed to select motors for applications which require square-law torque over the speed range, as is the case, for example, with pumps and fans. Field weakening is not permissible.

The motor's power is frequency-dependent. It can be approximated in kW from torque M in Nm, the 50 Hz or 60 Hz speed n and the frequency f in Hz by means of the equation

$$P = M \times n / 9550 \times f/50$$

or

$$P = M \times n / 9550 \times f/60$$

If a frequency inverter is used in conjunction with a pulse generator, the full 50 Hz or 60 Hz rated torque is available as holding torque at motor standstill (independent fan required for prolonged periods at standstill). In many instances, however, a mechanical brake is necessary for holding a position exactly or for safety reasons.

The use of thermistors for the thermal protection of the motor winding for frequency inverter duty are strictly recommended (available at extra cost for all motor sizes).

#### Increased torque with reduced duty factor

A reduction in duty factor increases the torque available at the low end of the frequency range (up to the transition frequency for field weakening) in accordance with the factors in the table below:

Duty factor	Motor torque with reduced duty factor	Increase in current requirement approximate
100 %	-	-
60 %	1.15 x S1 torque	1.15 x S1 current
40 %	1.30 x S1 torque	1.30 x S1 current
25 %	1.45 x S1 torque	1.45 x S1 current
15 %	1.60 x S1 torque	1.60 x S1 current

This, in turn, means that short-term overload by a factor of 1.6 is permissible for starting from a low speed, for example. An increase in torque in the field-weakening range due to a reduction in duty factor is possible only under certain conditions; the 1.6x S1 torque generally cannot be achieved

#### Increased torque with external fan

If an independent fan is used, the S1-torque in the lower frequency range (below 30 Hz) need not be reduced, i.e., when it has an independent fan the motor can provide the 50 Hz or 60 Hz rated torque throughout the entire frequency range to the cut-off frequency of the field weakening.

With a high quality frequency inverter of 160 %, when independent ventilation is combined with a reduced duty factor the 50 Hz or 60 Hz torque is available from rest through to the transition frequency of the field weakening range.

External ventilation is available for motor types D..08.. and larger (see chapter 16 "Motor-independent fan (FV). In many instances, a more economical alternative is to select a larger motor without external ventilation.

### **Energy-saving function**

High quality frequency inverters reduce voltage in part-load operation to lower the motor current and thus improve efficiency. This converter function emulates the method of operation of commercially available "energy-saving devices".

### **Regeneration**

Regenerative torques (braking torques) are required for motors used in lifting gear, for example. In conjunction with high quality frequency inverters, the motor torques listed in the table can also be applied as regenerative torques. As with motor torque, an increase in regenerative torque with reduced duty factor is permissible.

### **Notes on operation with other-make frequency inverters**

The precondition is that the motor current generated by the frequency converter is largely free of harmonics. The harmonics generated in the motor by some old-style frequency inverters result in additional losses and cut available torque by some 10 % across the entire frequency range. There is also a risk of oscillation causing damage to the gear unit.

At frequencies below approximately 5 Hz, operation without pulse generators is possible only using a frequency inverter with state-of-the-art control. If frequency inverters are used that do not feature load-dependent frequency and current adjustment, the increase in the motor's current consumption means that, particularly in the case of small motors (D..04.-D..09.), torque has to be reduced at frequencies below approximately 10 Hz even if an external fan is used or the duty factor is reduced. Regenerative operation is possible only under certain circumstances.

## Technical data of the 50 Hz motors

50 Hz

## 4-pole IE1 motors for continuous operation S1, line frequency 50 Hz

P <sub>N</sub> kW	Type	n <sub>N</sub> 1/min	M <sub>N</sub> Nm	I <sub>N</sub> (400V) A	Connection	cosφ	η (100%- load) %	η (75%- load) %	η (50%- load) %	I <sub>A</sub> /I <sub>N</sub>	M <sub>A</sub> /M <sub>N</sub>	M <sub>S</sub> /M <sub>N</sub>	M <sub>K</sub> /M <sub>N</sub>	J <sub>rot</sub> kgm <sup>2</sup>	Brake
0.03	D04LA4	1350	0.21	0.20	Y	0.60	-	-	-	2.2	2.6	2.6	3.0	0.000175	E003
0.04	D04LA4	1350	0.28	0.20	Y	0.60	-	-	-	2.2	2.0	2.0	2.3	0.000175	
0.06	D04LA4	1350	0.42	0.30	Y	0.60	-	-	-	2.3	2.1	2.1	2.4	0.000175	
0.09	D04LA4	1350	0.63	0.45	Y	0.69	-	-	-	2.5	2.2	2.2	2.6	0.000175	
0.11	D04LA4	1350	0.78	0.45	Y	0.68	-	-	-	2.2	1.9	1.9	2	0.000175	
0.06	D05LA4	1350	0.42	0.35	Y	0.72	-	-	-	3.7	3.7	3.5	3.7	0.000295	E003
0.09	D05LA4	1350	0.63	0.38	Y	0.70	-	-	-	3.9	3.0	2.8	3.0	0.000295	
0.06	D06LA4	1350	0.42	0.35	Y	0.72	-	-	-	3.7	3.7	3.5	3.7	0.000295	E003
0.09	D06LA4	1350	0.63	0.38	Y	0.70	-	-	-	3.9	3.0	2.8	3.0	0.000295	
0.12	DSE04LA4	1350	0.87	0.45	Y	0.72	53.4	51.4	43.2	2.3	1.7	1.4	1.8	0.000175	
0.18	DSE05LA4	1350	1.28	0.63	Y	0.66	63	61.7	54.9	3.4	2.2	2.2	2.4	0.000295	
0.2	DSE05LA4	1350	1.42	0.66	Y	0.71	61.6	61.7	54.9	3.3	2	2	2.2	0.000295	
0.25	DSE05LA4	1350	1.75	0.87	Y	0.68	61.5	58.8	54	2.6	2	2	2.1	0.000295	
0.18	DSE06LA4	1350	1.28	0.63	Y	0.65	63.5	61.7	53.1	3.1	2.4	2.3	2.5	0.000295	
0.2	DSE06LA4	1350	1.42	0.65	Y	0.7	62.5	61.7	53.1	3.3	2	2	2.2	0.000295	
0.25	DSE06LA4	1350	1.75	0.87	Y	0.68	61.5	58.8	51.4	2.6	2	2	2.1	0.000295	
0.37	DSE07LA4	1350	2.6	1.15	Y	0.71	66	65.2	59.7	3	2.2	2.1	2.2	0.000385	
0.55	DSE08MA4	1400	3.75	1.45	Y	0.72	75.4	75.2	72.0	4.2	2.1	2.0	2.4	0.00115	ES(X)010 EH(X)010 EH(X)027
0.75	DSE08LA4	1400	5.1	1.95	Y	0.76	75.6	76.2	72.7	4.6	2.0	2.0	2.4	0.00150	
1.1	DSE08XA4	1400	7.5	2.8	Y	0.75	75.5	76.8	73.5	3.7	2.0	1.8	2.2	0.00170	
1.1	DSE09SA4	1420	7.5	2.6	Y	0.76	80.0	80	77.5	4.9	2.5	2.2	2.8	0.00245	ES(X)010 ES(X)027 EH(X)027 EH(X)040
1.5	DSE09LA4	1420	10.1	3.5	Y	0.76	80.7	80.9	79.5	5.0	2.5	2.3	2.9	0.00320	
2.2	DSE09XA4	1420	15	4.9	Y	0.81	80.5	81.1	80.4	4.5	2.3	2.2	2.6	0.00380	
3	DSE11SA4	1420	20	6.4	D	0.80	84.4	85.0	83.8	5.9	2.7	2.5	3.2	0.00810	ES(X)027 ES(X)040 ES(X)070 EH(X)070 EH(X)125
4	DSE11MA4	1420	27	8.4	D	0.83	84.0	84.9	84.2	5.5	2.8	2.4	3.0	0.01050	
5.5	DSE11LA4	1420	37	11.3	D	0.83	85.8	86.2	85.4	6.3	2.8	2.6	3.2	0.014	

P <sub>N</sub>	Rated power
n <sub>N</sub>	Guideline value for rated speed at the rotor shaft
M <sub>N</sub>	Rated torque at the rotor shaft
I <sub>N</sub>	Rated current (the current can be converted in inverse ratio to the voltages for the desired special voltage)
cosφ	Power factor
η	Efficiency at different loads
I <sub>A</sub> /I <sub>N</sub>	Relative starting current
M <sub>A</sub> /M <sub>N</sub>	Relative starting torque
M <sub>S</sub> /M <sub>N</sub>	Relative pull-up torque
M <sub>K</sub> /M <sub>N</sub>	Relative breakdown torque
J <sub>rot</sub>	Mass moment of inertia of the rotor
Brake	Brake dimensioning see chapter "Motor Mounted Components-Dimensions"

Winding configuration for standard motors for 400 V / 50 Hz.

See "www.bauergears.com" for more information.

Continuous operation S1, 50 Hz

50 Hz

4-pole IE2 motors for continuous operation S1, line frequency 50 Hz

4-pole IE2 motors for continuous operation S1, line frequency 50 Hz		Power losses in % at operating points (Speed/Torque)																	
$\eta$ (100 %-Load)	$\eta$ (75 %-Load)	$\eta$ (50 %-Load)	IE Class	Manufacturer data	Type	Number of poles	P	Frequency	Voltage	$n_N$	Type of motor	Operating conditions	25/25	25/100	50/25	50/50	50/100	90/50	90/100
66.1	64.6	58.3	IE2	1) DHE05LA4	4	0.12	50	400	1390	2)	3)	24.7	46.0	28.8	30.9	46.1	36.0	50.7	
65.9	64.1	57.7	IE2	1) DHE06LA4	4	0.12	50	400	1385	2)	3)	25.0	47.0	29.3	31.3	47.1	36.5	51.8	
68.3	67.3	61.9	IE2	1) DHE05LA4	4	0.18	50	400	1375	2)	3)	16.9	46.8	22.6	25.3	43.0	30.4	45.9	
68	67	61.4	IE2	1) DHE06LA4	4	0.18	50	400	1370	2)	3)	17.2	46.2	23.0	25.8	43.3	32.3	49.6	
69.4	68.7	63.6	IE2	1) DHE07LA4	4	0.25	50	400	1375	2)	3)	15.1	43.4	20.0	22.8	39.9	27.6	42.6	
70.8	70.5	66	IE2	1) DHE07LA4	4	0.3	50	400	1360	2)	3)	19.1	37.5	20.6	22.7	38.0	25.6	41.0	
75.9	74.6	69.6	IE2	1) DHE08MA4	4	0.37	50	400	1430	2)	3)	11.3	26.2	15.0	16.7	26.8	21.5	31.1	
78.1	78.9	76.2	IE2	1) DHE08LA4	4	0.55	50	400	1415	2)	3)	7.6	29.8	10.0	12.6	26.0	15.9	27.8	

1) Manufacturer:	Bauer Gear Motor GmbH	2) Type of motor:	three-phase motor	3) Installation altitude above sea level (m):	1000
Commercial register number:	HRB 736269			Ambient temperature:	-20 °C to +40 °C
Address:	Eberhard-Bauer-Str. 37, 73734 Esslingen/Germany				

## Technical data of the 50 Hz motors

50 Hz

## 4-pole IE2 motors for continuous operation S1, mains frequency 50 Hz

P <sub>N</sub> kW	Type	n <sub>N</sub> 1/min	M <sub>N</sub> Nm	I <sub>N</sub> (400V) A	Connection	cosφ	η (100%- Last) %	η (75%- Last) %	η (50%- Last) %	I <sub>A</sub> /I <sub>N</sub>	M <sub>A</sub> /M <sub>N</sub>	M <sub>S</sub> /M <sub>N</sub>	M <sub>K</sub> /M <sub>N</sub>	J <sub>rot</sub> kgm <sup>2</sup>	Brake
0.12	DHE05LA4	1390	0.82	0.39	Y	0.67	66.1	64.6	58.3	3.3	2.3	2.3	2.5	0.000295	E003
0.12	DHE06LA4	1385	0.83	0.39	Y	0.67	65.9	64.1	57.7	3.3	2.3	2.3	2.5	0.000295	
0.18	DHE05LA4	1375	1.25	0.57	Y	0.67	68.3	67.3	61.9	3.4	2.6	2.5	2.6	0.000295	
0.18	DHE06LA4	1370	1.25	0.58	Y	0.67	68	67	61.4	3.3	2.5	2.5	2.6	0.000295	
0.25	DHE07LA4	1375	1.74	0.76	Y	0.68	69.4	68.7	63.6	3.5	2.7	2.6	2.7	0.000385	E003 E004
0.3	DHE07LA4	1360	2.1	0.9	Y	0.67	70.8	70.5	66	3.5	2.8	2.7	2.7	0.000385	ES(X)010 EH(X)010 EH(X)027
0.37	DHE08MA4	1430	2.4	1.1	Y	0.65	75.9	74.6	69.6	4.5	2.5	2.4	3	0.00115	
0.55	DHE08LA4	1415	3.7	1.38	Y	0.74	78.1	78.9	76.2	4.5	2.3	2.1	2.6	0.0015	
0.75	DHE08XA4	1420	5.0	1.88	Y	0.72	79.7	80.0	77.4	4.7	2.3	2.2	2.7	0.00170	ES(X)010 ES(X)027 EH(X)027 EH(X)040
0.75	DHE09SA4	1440	5.0	1.8	Y	0.73	81.6	81.0	77.4	5.9	3.1	2.7	3.5	0.00245	
1.1	DHE09LA4	1440	7.3	2.5	Y	0.75	82.7	82.3	79.8	5.9	2.9	2.7	3.4	0.0032	
1.5	DHE09XA4	1440	10.0	3.3	Y	0.78	83.2	82.8	79.5	5.6	3.0	2.9	3.3	0.0038	
2.2	DHE09XB4	1420	14.8	4.7	Y	0.79	84.5	85.2	83.9	6.0	3.1	2.5	3.3	0.0049	ES(X)027 ES(X)040 ES(X)070 EH(X)070 EH(X)125
2.2	DHE11SA4	1440	14.5	4.6	Y	0.80	86.2	86.0	84.7	7.0	3.1	2.8	3.6	0.0081	
3	DHE11MA4	1440	20	6.3	D	0.8	86.5	86.5	84.7	6.7	3.4	2.8	3.7	0.0105	
4	DHE11LA4	1440	26.5	8.4	D	0.79	87.5	87	85.3	7.6	3.6	3.3	4.2	0.014	
5.5	DHE11LB4	1450	36	11	D	0.82	88.1	88.5	87.4	7.9	3.3	2.9	3.8	0.017	

P <sub>N</sub>	Rated power
n <sub>N</sub>	Guideline value for rated speed at the rotor shaft
M <sub>N</sub>	Rated torque at the rotor shaft
I <sub>N</sub>	Rated current (the current can be converted in inverse ratio to the voltages for the desired special voltage)
cosφ	Power factor
η	Efficiency at different loads
I <sub>A</sub> /I <sub>N</sub>	Relative starting current
M <sub>A</sub> /M <sub>N</sub>	Relative starting torque
M <sub>S</sub> /M <sub>N</sub>	Relative pull-up torque
M <sub>K</sub> /M <sub>N</sub>	Relative breakdown torque
J <sub>rot</sub>	Mass moment of inertia of the rotor
Brake	Brake dimensioning see chapter "Motor Mounted Components-Dimensions"

Winding configuration for standard motors for 400 V / 50 Hz.

All motors are suitable for the voltage range 380...420 V or 400 V +/- 10 % if executed in insulation class F.

**Important:** Current, power factor and torque change as voltage deviates from 400 V.

See "www.bauergears.com" for more information.

Continuous operation S1, 50 Hz

50 Hz

### 4-pole IE3 motors for continuous operation S1, line frequency 50 Hz

		Power losses in % at operating points (Speed/Torque)																		
		25/25	25/100	50/25	50/50	50/100	90/50	90/100												
$\eta$ (100 %-Load)	%	69.3	67.1	60.5	67.1	60.5	67.1	60.5	67.1	60.5	67.1	60.5	67.1	60.5	67.1	60.5	67.1	60.5	67.1	
$\eta$ (75 %-Load)	%	68.8	66.4	59.9	66.4	59.9	66.4	59.9	66.4	59.9	66.4	59.9	66.4	59.9	66.4	59.9	66.4	59.9	66.4	
$\eta$ (50 %-Load)	%	70.8	69.3	63.9	69.3	63.9	69.3	63.9	69.3	63.9	69.3	63.9	69.3	63.9	69.3	63.9	69.3	63.9	69.3	
IE Class		IE3	IE3	IE3	IE3	IE3	IE3	IE3	IE3	IE3	IE3	IE3	IE3	IE3	IE3	IE3	IE3	IE3	IE3	
Manufacturer data		1)	1)	1)	1)	1)	1)	1)	1)	1)	1)	1)	1)	1)	1)	1)	1)	1)	1)	
Type		DPE05LA4	DPE06LA4	DPE07LA4	DPE08MA4	DPE08LA4	DPE08XA4	DPE08XB4	DPE09LA4	DPE09XA4	DPE09XB4	DPE09XB4C	DPE11MA4	DPE11LA4	DPE11LB4	DPE11LB4C				
Number of poles		4	4	4	4	4	4	4	4	4	4	4	4	4	4	4	4	4	4	
P	kW	0.12	0.12	0.18	0.25	0.37	0.55	0.75	0.75	1.1	1.5	2.2	2.2	3	4	5.5				
Frequency	Hz	50	50	50	50	50	50	50	50	50	50	50	50	50	50	50	50	50	50	
Voltage	V	400	400	400	400	400	400	400	400	400	400	400	400	400	400	400	400	400	400	
$n_N$	1/min	1405	1400	1400	1440	1445	1430	1425	1440	1440	1435	1450	1450	1455	1450	1465				
Type of motor		2)	2)	2)	2)	2)	2)	2)	2)	2)	2)	2)	2)	2)	2)	2)	2)	2)	2)	
Operating conditions		3)	3)	3)	3)	3)	3)	3)	3)	3)	3)	3)	3)	3)	3)	3)	3)	3)	3)	
		25/25	25/100	50/25	50/50	50/100	90/50	90/100												
1) Manufacturer:		Bauer Gear Motor GmbH																		
Commercial register number:		HRB 736269																		
Address:		Eberhard-Bauer-Str. 37, 73734 Esslingen/Germany																		
		2) Type of motor: three-phase motor																		
		3) Installation altitude above sea level (m): 1000 Ambient temperature: -20 °C to +40 °C																		



## Technical data of the 50 Hz motors

50 Hz

## 4-pole IE3 motors for continuous operation S1, mains frequency 50 Hz

$P_N$ kW	Type	$n_N$ 1/min	$M_N$ Nm	$I_N$ (400V) A	Connection	$\cos\varphi$	$\eta$ (100%-Load) %	$\eta$ (75%-Load) %	$\eta$ (50%Load) %	$I_A/I_N$	$M_A/M_N$	$M_S/M_N$	$M_K/M_N$	$J_{rot}$ kgm <sup>2</sup>	Brake
0.12	DPE05LA4	1405	0.82	0.4	Y	0.62	69.3	67.1	60.5	3.8	3	3	3.1	0.000295	E003
0.12	DPE06LA4	1400	0.82	0.41	Y	0.63	68.8	66.4	59.9	3.7	3	3	3.1	0.000295	E003
0.18	DPE07LA4	1400	1.23	0.56	Y	0.65	70.8	69.3	63.9	3.9	3.1	3	3.1	0.000385	E003. E004
0.25	DPE08MA4	1440	1.66	0.71	Y	0.66	77.7	76.4	71.8	4.9	2.6	2.5	3.1	0.00115	ES(X)010 EH(X)010/027
0.37	DPE08LA4	1445	2.45	1.03	Y	0.64	79.9	78.8	74.3	5.5	3.2	3	3.6	0.0015	
0.55	DPE08XA4	1430	3.65	1.4	Y	0.7	81.2	81	77.9	5.3	2.9	2.7	3.2	0.0017	
0.75	DPE08XB4	1425	5	1.86	Y	0.71	82.5	83.1	81.3	5.3	3.1	2.8	3.3	0.002	
0.75	DPE09LA4	1440	5	1.67	Y	0.79	82.7	82.5	79.1	6.6	3.4	3	3.6	0.0032	ES(X)010/027 EH(X)027/040
1.1	DPE09XA4	1440	7.3	2.4	Y	0.78	84.4	84.3	81.9	6.7	3.4	3.1	3.7	0.0038	
1.5	DPE09XB4	1435	10	3.25	Y	0.79	85.5	86.1	84.5	6.5	3.2	3	3.6	0.0049	
2.2	DPE09XB4C	1450	14.5	4.7	Y	0.77	86.8	87.4	85.9	6.7	2.6	2.4	3.6	0.0069	ES(X)027/040/070 EH(X)070/125
2.2	DPE11MA4	1450	14.5	4.6	Y	0.8	87.1	87.2	85.2	7.3	3.2	2.7	3.9	0.0105	
3	DPE11LA4	1455	19.7	6.2	D	0.8	87.7	87.6	85.5	8.3	3.7	3	4.4	0.014	
4	DPE11LB4	1450	26.5	7.8	D	0.83	89.4	90.3	89.5	7.8	3.3	2.6	4	0.017	
5.5	DPE11LB4C	1465	36	11	D	0.8	90	89.4	88	8.2	2.7	2.4	4	0.022	

$P_N$	Rated power
$n_N$	Guideline value for rated speed at the rotor shaft
$M_N$	Rated torque at the rotor shaft
$I_N$	Rated current (the current can be converted in inverse ratio to the voltages for the desired special voltage)
$\cos\varphi$	Power factor
$\eta$	Efficiency at different loads
$I_A/I_N$	Relative starting current
$M_A/M_N$	Relative starting torque
$M_S/M_N$	Relative pull-up torque
$M_K/M_N$	Relative breakdown torque
$J_{rot}$	Mass moment of inertia of the rotor
Brake	Brake dimensioning see chapter "Motor Mounted Components-Dimensions"

Winding configuration for standard motors for 400 V / 50 Hz.

All motors are suitable for the voltage range 380...420 V or 400 V +/- 10 % if executed in insulation class F.

**Important:** Current, power factor and torque change as voltage deviates from 400 V.

See "www.bauergears.com" for more information.

### Technical data of the 50 Hz motors

**50 Hz**

#### 4 pole motors for periodic duty S3/S6-75 %, Mains Frequency 50 Hz

$P_N$ kW	Type	$n_N$ 1/min	$M_N$ Nm	$I_N$ (400V) A	Connection	$\cos\phi$	$I_A/I_N$	$M_A/M_N$	$M_S/M_N$	$M_K/M_N$	$J_{rot}$ kgm <sup>2</sup>	Brake
0.75	DSE08MA4	1320	5.4	2	Y	0.81	2.9	1.5	1.4	1.7	0.00115	ES(X)010
0.9	DSE08LA4	1350	6.3	2.3	Y	0.79	3.4	1.6	1.6	2	0.0015	
1.25	DSE08XA4	1350	8.8	3.1	Y	0.8	3.3	1.6	1.6	1.9	0.0017	
1.65	DSE09SA4	1370	11.5	3.7	Y	0.86	3.5	1.6	1.5	1.8	0.00245	ES(X)010 ES(X)027
2.2	DSE09LA4	1370	15.5	5	Y	0.86	3.6	1.7	1.6	2	0.0032	
2.5	DSE09XA4	1370	17.3	5.5	Y	0.84	4	2	1.9	2.3	0.0038	ES(X)027 ES(X)040 ES(X)070
3.7	DSE11SA4	1400	25	7.8	D	0.85	4.1	2.2	2	2.6	0.0081	
5	DSE11MA4	1380	34	10.3	D	0.86	4.4	2.2	1.9	2.4	0.0105	ES(X)027 ES(X)040 ES(X)070
6.6	DSE11LA4	1400	44	13.5	D	0.86	4.8	2.4	2.1	2.7	0.014	

$P_N$	Rated power
$n_N$	Guideline value for rated speed at the rotor shaft
$M_N$	Rated torque at the rotor shaft
$I_N$	Rated current (the current can be converted in inverse ratio to the voltages for the desired special voltage)
$\cos\phi$	Power factor
$\eta$	Efficiency at different loads
$I_A/I_N$	Relative starting current
$M_A/M_N$	Relative starting torque
$M_S/M_N$	Relative pull-up torque
$M_K/M_N$	Relative breakdown torque
$J_{rot}$	Mass moment of inertia of the rotor
Brake	Brake dimensioning see chapter "Motor Mounted Components-Dimensions"

The standard motor winding configuration is for 400 V / 50 Hz.

See "www.bauergears.com" for more information.

## Technical data of the 50 Hz motors

50 Hz

## 4 pole motors for periodic duty S3/S6, Mains Frequency 50 Hz

$P_N$ kW	ED	Type	$n_N$ 1/min	$M_N$ Nm	$I_N$ (400V) A	Connec- tion	$\cos\phi$	$I_A/I_N$	$M_A/M_N$	$M_S/M_N$	$M_K/M_N$	$J_{rot}$ kgm <sup>2</sup>
0.15	15%	D04LA4	1350	1.05	0.6	Y	0.77	2	1.6	1.5	1.6	0.000175
0.3	15%	D05LA4	1350	2.1	0.98	Y	0.75	2.6	1.9	1.8	1.9	0.000295
0.3	60%	D06LA4	1350	2.1	0.98	Y	0.75	2.6	1.9	1.8	1.9	0.000295
0.55	60%	D07LA4	1350	3.9	1.95	Y	0.86	3.4	1.6	1.5	1.6	0.000385
0.75	60%	D08MA4	1400	5.1	2	Y	0.81	3.4	1.6	1.4	1.7	0.00115
1.1	60%	D08LA4	1400	7.5	2.8	Y	0.82	3.3	1.5	1.4	1.7	0.0015
1.5	60%	D09SA4	1400	10.2	3.6	Y	0.84	3.9	1.7	1.5	2	0.00245
2.2	60%	D09LA4	1400	15	5	Y	0.86	3.9	1.6	1.5	1.9	0.0032
3	60%	D09XA4	1400	20	6.8	Y	0.86	3.4	1.7	1.6	1.9	0.0038
4	60%	D11SA4	1420	26.5	8.9	$\Delta$	0.85	4	1.6	1.4	2	0.0081
5.5	60%	D11MA4	1420	37	11.7	$\Delta$	0.87	4.3	1.5	1.5	2	0.0105
7.5	60%	D11LA4	1420	50	16	$\Delta$	0.87	4.3	1.8	1.7	2.1	0.014

$P_N$	Rated power
ED	Duty cycle
$n_N$	Guideline value for rated speed at the rotor shaft
$M_N$	Rated torque at the rotor shaft
$I_N$	Rated current (the current can be converted in inverse ratio to the voltages for the desired special voltage)
$\cos\phi$	Power factor
$I_A/I_N$	Relative starting current
$M_A/M_N$	Relative starting torque
$M_S/M_N$	Relative pull-up torque
$M_K/M_N$	Relative breakdown torque
$J_{rot}$	Mass moment of inertia of the rotor

The standard motor winding configuration is for 400 V / 50 Hz.

See "www.bauergears.com" for more information.

### Technical data of the 50 Hz motors

**50 Hz**

#### 4/2-pole Δ/YY motors for continuous running duty (S1) and 50 Hz mains frequency

$P_N$ kW	Type	$n_N$ 1/min	$M_N$ Nm	$I_N$ (400V) A	$\cos\phi$	$I_A/I_N$	$M_A/M_N$	$M_S/M_N$	$M_K/M_N$	$J_{rot}$ kgm <sup>2</sup>
0.03/0.06	D04LA42	1350/2700	0.210/0.210	0.230/0.250	0.56/0.67	2.2/3.1	3.4/3.1	3.4/3.1	3.6/3.3	0.000175
0.04/0.08	D04LA42	1350/2700	0.280/0.280	0.250/0.280	0.60/0.75	2.0/2.8	3.0/2.1	3.0/2.1	3.3/2.2	0.000175
0.06/0.12	D05LA42	1350/2700	0.420/0.420	0.450/0.450	0.50/0.75	2.8/3.3	3.1/2.0	3.0/1.9	3.8/2.6	0.000295
0.08/0.16	D05LA42	1350/2700	0.56/0.56	0.50/0.50	0.55/0.75	2.8/3.3	3.1/1.8	2.7/1.7	3.4/2.3	0.000295
0.06/0.12	D06LA42	1350/2700	0.420/0.420	0.450/0.450	0.50/0.75	2.8/3.3	3.1/2.0	3.0/1.9	3.8/2.6	0.000295
0.08/0.16	D06LA42	1350/2700	0.56/0.56	0.50/0.50	0.55/0.75	2.8/3.3	2.8/1.8	2.7/1.7	3.4/2.3	0.000295
0.11/0.22	D06LA42	1350/2700	0.77/0.77	0.68/0.68	0.55/0.75	2.8/3.3	2.8/1.8	2.7/1.7	3.4/2.3	0.000295
0.16/0.32	D06LA42	1350/2700	1.13/1.13	0.90/0.90	0.57/0.80	2.8/3.3	2.6/1.7	2.5/1.6	3.1/2.1	0.000295
0.2/0.4	D07LA42	1400/2800	1.35/1.37	1.10/1.15	0.58/0.81	2.9/3.6	2.8/1.6	2.7/1.4	3.0/2.0	0.000385
0.28/0.56	D08MA42	1400/2800	1.90/1.90	1.20/1.75	0.61/0.81	3.4/2.9	2.3/1.5	2.3/1.4	3.0/1.9	0.00115
0.4/0.8	D08LA42	1400/2800	2.7/2.7	1.53/1.91	0.62/0.90	4.7/5.1	2.7/1.8	2.4/1.7	3.1/2.1	0.0015
0.5/1.0	D09SA42	1400/2800	3.4/3.4	1.65/2.4	0.71/0.91	5.1/4.5	2.9/1.9	2.9/1.9	3.6/2.4	0.00245
0.7/1.4	D09SA42	1400/2800	4.8/4.8	2.1/3.3	0.71/0.93	4.7/4.1	2.5/1.6	2.5/1.6	3.1/2.0	0.00245
1.0/2.0	D09LA42	1400/2800	6.8/6.8	2.9/4.7	0.72/0.94	4.7/4.1	2.5/1.6	2.5/1.6	3.1/2.0	0.0032
1.2/2.4	D09XA42	1400/2800	8.2/8.1	3.8/5.7	0.65/0.87	6.2/3.0	2.5/1.8	2.5/1.8	3.1/2.3	0.0038
1.4/2.8	D11SA42	1420/2840	9.4/9.4	3.6/6.2	0.74/0.90	6.4/4.5	3.0/1.7	2.6/1.5	4.1/2.8	0.0081
2.0/4.0	D11MA42	1420/2840	13.5/13.4	5.5/9.1	0.70/0.90	6.7/5.4	3.1/2.1	2.7/1.6	3.7/2.5	0.0105
2.5/5.0	D11LA42	1420/2840	16.8/16.8	5.5/10	0.79/0.92	5.6/4.6	2.8/1.8	2.7/1.7	3.7/2.6	0.014

$P_N$	Rated power
$n_N$	Guideline value for rated speed at the rotor shaft
$M_N$	Rated torque at the rotor shaft
$I_N$	Rated current (the current can be converted in inverse ratio to the voltages for the desired special voltage)
$\cos\phi$	Power factor
$I_A/I_N$	Relative starting current
$M_A/M_N$	Relative starting torque
$M_S/M_N$	Relative pull-up torque
$M_K/M_N$	Relative breakdown torque
$J_{rot}$	Mass moment of inertia of the rotor

The standard motor winding configuration is for 400 V / 50 Hz.

See "www.bauergears.com" for more information.

## Technical data of the 50 Hz motors

50 Hz

8/4-pole  $\Delta/YY$  motors for continuous running duty (S1) and 50 Hz mains frequency

$P_N$ kW	Type	$n_N$ 1/min	$M_N$ Nm	$I_N$ (400V) A	$\cos\varphi$	$I_A/I_N$	$M_A/M_N$	$M_S/M_N$	$M_K/M_N$	$J_{rot}$ kgm <sup>2</sup>
0.03/0.06	D05LA84	680/1350	0.410/0.420	0.300/0.280	0.52/0.71	1.6/2.6	2.7/1.9	1.6/1.7	1.6/1.7	0.000295
0.03/0.06	D06LA84	680/1350	0.410/0.420	0.300/0.280	0.52/0.71	1.6/2.6	2.7/1.9	1.6/1.7	1.6/1.7	0.000295
0.04/0.08	D06LA84	680/1350	0.54/0.56	0.480/0.400	0.52/0.66	1.4/2.2	2.6/2.1	1.6/1.7	1.6/1.7	0.000295
0.06/0.12	D07LA84	680/1350	0.84/0.85	0.70/0.60	0.52/0.66	1.7/2.8	3.2/1.7	3.2/1.5	3.3/2.1	0.000385
0.06/0.12	D08LA84	700/1400	0.81/0.81	0.50/0.50	0.61/0.83	2.8/3.7	3.1/2.3	3.1/2.3	3.7/3.1	0.0025
0.08/0.16	D08LA84	700/1400	1.08/1.09	0.62/0.62	0.61/0.83	2.8/3.7	3.0/2.2	3.0/2.2	3.5/3.0	0.0025
0.11/0.22	D08LA84	700/1400	1.49/1.5	0.80/0.80	0.61/0.83	2.8/3.7	2.8/2.1	2.8/2.1	3.3/2.8	0.0025
0.14/0.28	D08LA84	700/1400	1.90/1.91	1.00/1.00	0.61/0.83	2.8/3.7	2.8/2.1	2.8/2.1	3.3/2.8	0.0025
0.2/0.4	D08LA84	700/1400	2.7/2.7	1.10/1.30	0.55/0.77	2.8/3.7	2.3/1.7	2.3/1.7	2.7/2.3	0.0025
0.25/0.5	D09XC84	700/1400	3.3/3.3	1.40/1.40	0.48/0.77	2.9/5.0	2.7/2.0	2.7/2.1	3.1/2.7	0.006
0.28/0.56	D09XC84	700/1400	3.8/3.8	1.40/1.50	0.57/0.80	2.9/4.9	2.4/1.8	2.4/1.9	2.8/2.4	0.006
0.4/0.8	D09XC84	700/1400	5.4/5.4	1.95/2.4	0.55/0.79	2.8/4.2	2.3/1.7	2.3/1.8	2.7/2.3	0.006
0.5/1.0	D09XC84	700/1400	6.8/6.8	2.4/2.6	0.55/0.81	2.6/4.0	2.2/1.6	2.2/1.6	2.5/2.2	0.006
0.8/1.6	D11LC84	710/1420	10.7/10.7	3.0/4.2	0.63/0.88	3.5/4.3	2.2/1.9	2.2/1.7	2.8/2.7	0.0215
1.1/2.2	D11LC84	710/1420	14.7/14.7	4.0/5.0	0.58/0.85	3.9/5.7	2.3/2.1	2.3/1.7	2.7/2.5	0.0215
1.6/3.2	D11LC84	710/1420	21.5/21.5	6.0/7.6	0.59/0.84	3.7/5.1	2.2/1.8	2.1/1.5	2.6/2.3	0.0215

$P_N$	Rated power
$n_N$	Guideline value for rated speed at the rotor shaft
$M_N$	Rated torque at the rotor shaft
$I_N$	Rated current (the current can be converted in inverse ratio to the voltages for the desired special voltage)
$\cos\varphi$	Power factor
$I_A/I_N$	Relative starting current
$M_A/M_N$	Relative starting torque
$M_S/M_N$	Relative pull-up torque
$M_K/M_N$	Relative breakdown torque
$J_{rot}$	Mass moment of inertia of the rotor

The standard motor winding configuration is for 400 V / 50 Hz.

See "www.bauergears.com" for more information.

### Technical data of the 50 Hz motors

**50 Hz**

#### 8/2-pole Y/Y motors for intermittent periodic duty S3 25/75 % and 50 Hz mains frequency

$P_N$ kW	ED	Type	$n_N$ 1/min	$M_N$ Nm	$I_N$ (400V) A	$\cos\varphi$	$I_A/I_N$	$M_A/M_N$	$M_S/M_N$	$M_K/M_N$	$J_{rot}$ kgm <sup>2</sup>
0.04/0.16	25/75 %	D05LA82	680/2700	0.56/0.56	0.400/0.80	0.63/0.75	1.6/3.2	1.9/2.2	1.9/2.1	2.0/2.3	0.000295
0.05/0.20	25/75 %	D06LA82	680/2700	0.70/0.70	0.51/1.02	0.63/0.75	1.4/2.8	1.7/2.0	1.7/1.9	1.8/2.1	0.000295
0.063/0.25	25/75 %	D07LA82	650/2840	0.87/0.87	0.60/1.20	0.69/0.62	1.4/2.6	1.6/1.4	1.6/1.4	1.8/2.7	0.000385
0.071/0.28	25/75 %	D07LA82	650/2840	0.99/0.98	0.65/1.40	0.69/0.68	1.4/2.6	1.5/1.3	1.5/1.3	1.7/2.6	0.000385
0.063/0.25	25/75 %	D08LA82	700/2800	0.85/0.85	0.55/0.70	0.55/0.87	2.8/4.0	2.4/2.6	2.4/2.5	2.8/3.0	0.0015
0.09/0.36	25/75 %	D08LA82	700/2800	1.22/1.22	0.70/1.05	0.60/0.92	2.9/4.5	2.0/2.6	2.0/2.5	2.4/2.9	0.0015
0.12/0.5	25/75 %	D08LA82	700/2800	1.70/1.70	0.95/1.43	0.60/0.92	2.9/4.5	2.0/2.6	2.0/2.5	2.4/2.9	0.0015
0.16/0.63	25/75 %	D08LA82	700/2800	2.1/2.1	1.20/1.45	0.63/0.90	2.0/4.6	1.8/2.1	1.8/2.0	2.2/2.4	0.0015
0.25/1.0	25/75 %	D09XA82	700/2800	3.4/3.4	1.30/2.3	0.62/0.90	2.2/5.2	1.9/2.3	1.9/2.3	2.0/2.6	0.0038
0.36/1.4	25/75 %	D09XA82	700/2800	4.9/4.8	2.1/3.3	0.57/0.87	2.0/4.5	1.9/2.1	1.9/2.1	2.0/2.4	0.0038
0.45/1.8	25/75 %	D09XA82	700/2800	6.1/6.1	2.4/4.3	0.65/0.89	2.0/4.3	1.7/2.0	1.7/2.0	2.0/2.5	0.0038
0.56/2.2	25/75 %	D11LA82	710/2840	7.5/7.3	2.3/4.7	0.60/0.94	3.2/4.9	1.9/2.9	1.9/2.4	2.2/2.9	0.014
0.71/2.8	25/75 %	D11LA82	710/2840	9.5/9.4	2.8/5.6	0.58/0.94	2.5/4.7	1.9/2.3	1.9/2.0	2.1/2.4	0.014
0.90/3.6	25/75 %	D11LA82	710/2840	12.1/12.1	3.5/7.9	0.58/0.94	2.5/4.5	1.8/2.0	1.8/1.8	2.0/2.1	0.014

$P_N$	Rated power
ED	Duty cycle
$n_N$	Guideline value for rated speed at the rotor shaft
$M_N$	Rated torque at the rotor shaft
$I_N$	Rated current (the current can be converted in inverse ratio to the voltages for the desired special voltage)
$\cos\varphi$	Power factor
$I_A/I_N$	Relative starting current
$M_A/M_N$	Relative starting torque
$M_S/M_N$	Relative pull-up torque
$M_K/M_N$	Relative breakdown torque
$J_{rot}$	Mass moment of inertia of the rotor

The standard motor winding configuration is for 400 V / 50 Hz.

See "www.bauergears.com" for more information.

## Technical data of the 50 Hz motors

50 Hz

## 12/2-pole Y/Y motors for intermittent periodic duty S3 25/75 % and 50 Hz mains frequency

$P_N$ kW	DC	Type	$n_N$ 1/min	$M_N$ Nm	$I_N$ (400V) A	$\cos\phi$	$I_A/I_N$	$M_A/M_N$	$M_S/M_N$	$M_K/M_N$	$J_{rot}$ kgm <sup>2</sup>
0.045/0.28	25/75 %	D08LA122	470/2800	0.92/0.95	0.55/0.86	0.70/0.90	1.4/4.5	1.9/2.4	1.9/2.4	1.9/2.7	0.0015
0.063/0.4	25/75 %	D08LA122	470/2800	1.29/1.36	0.66/1.10	0.70/0.90	1.4/4.5	1.7/2.2	1.7/2.2	1.7/2.4	0.0015
0.09/0.56	25/75 %	D08LA122	470/2800	1.85/1.91	1.00/1.45	0.63/0.89	1.4/4.1	1.7/2.1	1.7/2.3	1.8/2.4	0.0015
0.11/0.71	25/75 %	D09XA122	470/2800	2.3/2.4	1.05/1.60	0.59/0.88	1.5/5.5	1.7/2.7	1.7/2.6	1.8/3.3	0.0038
0.16/1.0	25/75 %	D09XA122	470/2800	3.2/3.4	1.70/2.4	0.62/0.89	1.5/5.5	1.8/2.6	1.8/2.5	1.8/3.3	0.0038
0.20/1.25	25/75 %	D09XA122	470/2800	4.1/4.2	2.0/3.0	0.62/0.89	1.5/5.0	1.7/2.4	1.7/2.3	1.7/3.1	0.0038
0.25/1.6	25/75 %	D11LA122	470/2840	5.1/5.3	2.3/3.4	0.53/0.95	1.6/4.9	1.7/2.6	1.7/2.4	2.0/2.8	0.014
0.32/2.0	25/75 %	D11LA122	470/2840	6.5/6.7	2.9/4.0	0.53/0.94	1.6/4.7	1.7/2.5	1.7/2.2	2.0/2.7	0.014
0.45/2.8	25/75 %	D11LA122	470/2840	9.2/9.4	4.5/5.6	0.52/0.94	1.6/4.7	1.5/2.3	1.5/2.0	1.8/2.4	0.014

$P_N$	Rated power
ED	Duty cycle
$n_N$	Guideline value for rated speed at the rotor shaft
$M_N$	Rated torque at the rotor shaft
$I_N$	Rated current (the current can be converted in inverse ratio to the voltages for the desired special voltage)
$\cos\phi$	Power factor
$I_A/I_N$	Relative starting current
$M_A/M_N$	Relative starting torque
$M_S/M_N$	Relative pull-up torque
$M_K/M_N$	Relative breakdown torque
$J_{rot}$	Mass moment of inertia of the rotor

The standard motor winding configuration is for 400 V / 50 Hz.

See "www.bauergears.com" for more information.

### Technical data of the 60 Hz motors

**60 Hz**

#### 4-pole IE1 motors for continuous operation S1, mains frequency 60 Hz

P <sub>N</sub> kW	Type	n <sub>N</sub> 1/min	M <sub>N</sub> Nm	I <sub>N</sub> (460V) A	Connec- tion	cosφ	η (100%-Load) %	η (75%-Load) %	η (50%-Load) %	I <sub>A</sub> /I <sub>N</sub>	M <sub>A</sub> /M <sub>N</sub>	M <sub>S</sub> /M <sub>N</sub>	M <sub>K</sub> /M <sub>N</sub>	J <sub>rot</sub> kgm <sup>2</sup>	Brake
0.03	D04LA4	1620	0.17	0.18	Y	0.60	-	-	-	2.4	2.9	2.9	3.3	0.000175	E003
0.04	D04LA4	1620	0.23	0.18	Y	0.60	-	-	-	2.4	2.2	2.2	2.5	0.000175	
0.06	D04LA4	1620	0.35	0.28	Y	0.60	-	-	-	2.5	2.3	2.3	2.7	0.000175	
0.09	D04LA4	1620	0.52	0.40	Y	0.69	-	-	-	2.7	2.4	2.4	2.9	0.000175	
0.11	D04LA4	1620	0.64	0.42	Y	0.58	-	-	-	2.7	2.4	2.4	2.7	0.000175	
0.12	D04LA4	1620	0.7	0.42	Y	0.73	-	-	-	2.5	1.9	1.9	2.1	0.000175	
0.06	D05LA4	1620	0.35	0.32	Y	0.72	-	-	-	4.1	4.1	3.8	4.1	0.000295	E003
0.09	D05LA4	1620	0.52	0.35	Y	0.70	-	-	-	4.3	3.3	3.1	3.3	0.000295	
0.12	D05LA4	1620	0.7	0.38	Y	0.73	-	-	-	3.7	2.4	2.3	2.4	0.000295	
0.18	D05LA4	1620	1.06	0.58	Y	0.70	-	-	-	3.7	2.5	2.4	2.6	0.000295	
0.25	D05LA4	1620	1.45	0.80	Y	0.69	-	-	-	3.6	2.5	2.4	2.5	0.000295	E003
0.06	D06LA4	1620	0.35	0.32	Y	0.72	-	-	-	4.1	4.1	3.8	4.1	0.000295	
0.09	D06LA4	1620	0.52	0.35	Y	0.70	-	-	-	4.3	3.3	3.1	3.3	0.000295	
0.12	D06LA4	1620	0.7	0.38	Y	0.73	-	-	-	3.7	2.4	2.3	2.4	0.000295	
0.18	D06LA4	1620	1.06	0.58	Y	0.70	-	-	-	3.7	2.5	2.4	2.6	0.000295	
0.25	D06LA4	1620	1.45	0.80	Y	0.69	-	-	-	3.6	2.5	2.4	2.5	0.000295	E003 E004
0.3	D07LA4	1620	1.76	1.20	Y	0.60	-	-	-	3.0	3.0	3.0	3.1	0.000385	
0.37	D07LA4	1620	2.1	1.26	Y	0.66	-	-	-	2.8	2.4	2.4	2.4	0.000385	ES(X)010 EH(X)010 EH(X)027
0.55	DSE08MA4	1720	3.1	1.28	Y	0.72	75.4	75.2	73.0	4.6	2.3	2.2	2.7	0.00115	
0.75	DSE08LA4	1720	4.15	1.75	Y	0.69	78.2	77.0	72.7	4.8	2.5	2.4	2.9	0.00150	
1.1	DSE08XA4	1720	6.2	2.4	Y	0.71	79.0	77.0	73.0	4.1	2.2	2.0	2.4	0.00170	ES(X)010 ES(X)027 EH(X)027
1.1	DSE09SA4	1740	6.05	2.3	Y	0.72	83.6	82.6	79.2	6.5	3.6	3.3	4.0	0.00245	
1.5	DSE09LA4	1740	8.25	3.1	Y	0.72	84.2	83.5	80.4	6.5	3.4	3.1	4.0	0.00320	EH(X)040
2.2	DSE09XA4	1720	12.2	4.3	Y	0.76	84.9	85.0	83.0	6.2	3.3	3.0	3.6	0.00380	
3	DSE11SA4	1740	16.4	5.5	D	0.78	86.7	86.6	84.4	6.9	3.0	2.7	3.8	0.00810	ES(X)027 ES(X)040 ES(X)070 EH(X)070 EH(X)125
4	DSE11MA4	1740	21.9	7.2	D	0.81	86.2	86.4	84.9	6.9	3.3	2.7	3.7	0.01050	
5.5	DSE11LA4	1740	30.2	9.7	D	0.81	87.7	87.8	86	7.6	3.3	2.9	4	0.014	

P <sub>N</sub>	Rated power
n <sub>N</sub>	Guideline value for rated speed at the rotor shaft
M <sub>N</sub>	Rated torque at the rotor shaft
I <sub>N</sub>	Rated current (the current can be converted in inverse ratio to the voltages for the desired special voltage)
cosφ	Power factor
η	Efficiency at different loads
I <sub>A</sub> /I <sub>N</sub>	Relative starting current
M <sub>A</sub> /M <sub>N</sub>	Relative starting torque
M <sub>S</sub> /M <sub>N</sub>	Relative pull-up torque
M <sub>K</sub> /M <sub>N</sub>	Relative breakdown torque
J <sub>rot</sub>	Mass moment of inertia of the rotor
Brake	Brake dimensioning see chapter "Motor Mounted Components-Dimensions"

The standard motor winding configuration is for 460 V / 60 Hz.

See "www.bauergears.com" for more information.



Continuous operation S1, 60 Hz

60 Hz

4-pole IE2 motors for continuous operation S1, mains frequency 60 Hz

4-pole IE2 motors for continuous operation S1, mains frequency 60 Hz		Power losses in % at operating points (Speed/Torque)																	
$\eta$ (100 %-Load)	$\eta$ (75 %-Load)	$\eta$ (50 %-Load)	IE Class	Manufacturer data	Type	Number of poles	P	Frequency	Voltage	$n_N$	Type of motor	Operating conditions	25/25	25/100	50/25	50/50	50/100	90/50	90/100
68.8	65.8	58.9	IE2	1)	DHE05LA4	4	0.12	60	460	1710	2)	3)	23.6	35.4	26.0	28.4	38.1	34.1	44.0
68.4	65.4	58.1	IE2	1)	DHE06LA4	4	0.12	60	460	1710	2)	3)	24.3	35.9	26.8	29.1	38.5	34.9	44.5
71.6	69.3	63.1	IE2	1)	DHE05LA4	4	0.18	60	460	1700	2)	3)	20.4	32.0	22.3	24.6	34.0	29.0	38.7
71.2	68.8	62.4	IE2	1)	DHE06LA4	4	0.18	60	460	1700	2)	3)	20.4	32.0	22.4	24.7	34.1	29.3	39.0
72.6	70.3	64.6	IE2	1)	DHE07LA4	4	0.25	60	460	1700	2)	3)	17.8	29.3	19.8	22.1	31.5	26.9	36.6
74.6	73	67.6	IE2	1)	DHE07LA4	4	0.3	60	460	1690	2)	3)	16.1	27.6	17.7	20.1	29.4	23.9	33.4
77.8	75.7	70.1	IE2	1)	DHE08MA4	4	0.37	60	460	1745	2)	3)	12.1	19.9	14.0	15.6	22.1	20.2	27.1
80.5	79.9	76.3	IE2	1)	DHE08LA4	4	0.55	60	460	1730	2)	3)	8.7	18.3	10.2	12.2	20.0	15.7	24.0

1) Manufacturer: Commercial register number: Address:	Bauer Gear Motor GmbH HRB 736269 Eberhard-Bauer-Str. 37, 73734 Esslingen/Germany	2) Type of motor: three-phase motor	3) Installation altitude above sea level (m): 1000 Ambient temperature: -20 °C to +40 °C
--	--	-------------------------------------	---

### Technical data of the 60 Hz motors

**60 Hz**

#### 4-pole IE2 motors for continuous operation S1, mains frequency 60 Hz

P <sub>N</sub> kW	Type	n <sub>N</sub> 1/min	M <sub>N</sub> Nm	I <sub>N</sub> (460 V) A	Connec- tion	cosφ	η (100%-Last) %	η (75%-Last) %	η (50%-Last) %	I <sub>A</sub> /I <sub>N</sub>	M <sub>A</sub> /M <sub>N</sub>	M <sub>S</sub> /M <sub>N</sub>	M <sub>K</sub> /M <sub>N</sub>	J <sub>rot</sub> kgm <sup>2</sup>	Brake
0.12	DHE05LA4	1710	0.67	0.36	Y	0.61	68.8	65.8	58.9	4	2.8	2.8	3.2	0.000295	E003
0.12	DHE06LA4	1710	0.67	0.36	Y	0.6	68.4	65.4	58.1	3.9	2.8	2.8	3.3	0.000295	
0.18	DHE05LA4	1700	1.01	0.52	Y	0.61	71.6	69.3	63.1	4	3.2	3.1	3.3	0.000295	
0.18	DHE06LA4	1700	1.01	0.53	Y	0.6	71.2	68.8	62.4	3.9	3.2	3.1	3.3	0.000295	
0.25	DHE07LA4	1700	1.4	0.7	Y	0.62	72.6	70.3	64.6	4.2	3.4	3.2	3.5	0.000385	E003
0.3	DHE07LA4	1690	1.7	0.82	Y	0.62	74.6	73	67.6	4.2	3.5	3.3	3.5	0.000385	E004
0.37	DHE08MA4	1745	2	0.99	Y	0.6	77.8	75.7	70.1	5.9	2.9	2.7	3.6	0.00115	ES(X)010 EH(X)010 EH(X)027
0.55	DHE08LA4	1730	3	1.23	Y	0.69	80.5	79.9	76.3	5.4	2.7	2.4	3.2	0.0015	
0.75	DHE08XA4	1720	4.1	1.60	Y	0.72	82.5	81.0	78.0	5.1	2.5	2.4	3.0	0.0017	
0.75	DHE09SA4	1740	4.1	1.60	Y	0.70	83.7	82.4	78.3	7.3	3.4	3.0	4.0	0.00245	ES(X)010 ES(X)027 EH(X)027 EH(X)040
1.1	DHE09LA4	1740	6.0	2.25	Y	0.73	84.8	83.8	80.4	7.3	3.6	3.3	4.3	0.0032	
1.5	DHE09XA4	1740	8.2	2.95	Y	0.74	85.8	85.2	82.5	7.2	3.7	3.5	4.3	0.0038	
2.2	DHE09XB4	1740	12.1	4.1	Y	0.77	87.5	87.1	85.2	7.5	3.4	3.1	4.0	0.0049	
2.2	DHE11SA4	1760	12	4.0	Y	0.78	87.7	87.2	84.1	8.3	3.5	3.1	4.3	0.0081	ES(X)027 ES(X)040 ES(X)070 EH(X)070 EH(X)125
3	DHE11MA4	1760	16.5	5.5	D	0.78	87.6	87.2	83.9	7.9	3.9	3.1	4.4	0.0105	
4	DHE11LA4	1760	21.5	7.3	D	0.77	88.3	87.5	84.6	9.3	4.1	3.6	4.9	0.014	
5.5	DHE11LB4	1750	30	9.6	D	0.8	89.5	89.2	87.4	9.1	3.6	3.2	4.5	0.017	

P <sub>N</sub>	Rated power
n <sub>N</sub>	Guideline value for rated speed at the rotor shaft
M <sub>N</sub>	Rated torque at the rotor shaft
I <sub>N</sub>	Rated current (the current can be converted in inverse ratio to the voltages for the desired special voltage)
cosφ	Power factor
η	Efficiency at different loads
I <sub>A</sub> /I <sub>N</sub>	Relative starting current
M <sub>A</sub> /M <sub>N</sub>	Relative starting torque
M <sub>S</sub> /M <sub>N</sub>	Relative pull-up torque
M <sub>K</sub> /M <sub>N</sub>	Relative breakdown torque
J <sub>rot</sub>	Mass moment of inertia of the rotor
Brake	Brake dimensioning see chapter "Motor Mounted Components-Dimensions"

Winding configuration for standard motors for 460 V / 60 Hz.

All motors are suitable for the voltage range 440...480 V or 460 V +/- 10 % if executed in insulation class F.

**Important:** Current, power factor and torque change as voltage deviates from 460 V.

See "www.bauergears.com" for more information.

Continuous operation S1, 60 Hz

60 Hz

## 4-pole IE3 motors for continuous operation S1, line frequency 60 Hz

4-pole IE3 motors for continuous operation S1, line frequency 60 Hz		Power losses in % at operating points (Speed/Torque)																	
$\eta$ (100 %-Load)	$\eta$ (75 %-Load)	$\eta$ (50 %-Load)	IE Class	Manufacturer data	Type	Number of poles	P	Frequency	Voltage	$n_N$	Type of motor	Operating conditions	25/25	25/100	50/25	50/50	50/100	90/50	90/100
71.4	68.2	61	IE3	1) DPE05LA4	4	0.12	60	460	1715	2)	3)	20.4	30.2	22.9	24.9	32.8	30.7	38.9	
70.8	67.4	60.3	IE3	1) DPE06LA4	4	0.12	60	460	1715	2)	3)	20.6	30.5	23.1	25.2	33.3	31.1	39.6	
73.1	70.5	64.2	IE3	1) DPE07LA4	4	0.18	60	460	1715	2)	3)	16.9	27.1	19.1	21.2	29.5	26.4	35.1	
78.2	76.2	70.9	IE3	1) DPE08MA4	4	0.25	60	460	1745	2)	3)	11.6	19.7	13.8	15.5	22.3	21.0	28.4	
81.5	79.4	74.3	IE3	1) DPE08LA4	4	0.37	60	460	1750	2)	3)	8.7	15.0	10.5	11.8	17.0	16.1	21.6	
82.9	81.7	77.9	IE3	1) DPE08XA4	4	0.55	60	460	1740	2)	3)	7.6	15.0	9.1	10.6	16.7	14.1	20.5	
85	84.6	81.7	IE3	1) DPE08XB4	4	0.75	60	460	1735	2)	3)	6.5	14.1	7.5	9.1	15.3	11.4	18.0	
83.9	82.6	78.9	IE3	1) DPE09LA4	4	0.75	60	460	1750	2)	3)	5.0	11.5	6.9	8.3	13.7	12.8	18.8	
87.4	86.4	83.5	IE3	1) DPE09XB4	4	1.1	60	460	1755	2)	3)	5.3	10.6	6.6	7.7	12.0	10.8	15.3	
87.1	86.8	84.4	IE3	1) DPE09XB4	4	1.5	60	460	1745	2)	3)	5.0	11.6	6.1	7.4	12.9	9.9	15.7	
90.3	90	88.3	IE3	1) DPE11LB4	4	2.2	60	460	1760	2)	3)	3.3	7.9	4.3	5.2	9.0	7.5	11.6	
90.7	90.5	88.9	IE3	1) DPE11LB4	4	3	60	460	1760	2)	3)	2.5	7.5	3.8	4.8	8.8	7.0	11.0	
90.5	90.5	89.5	IE3	1) DPE11LB4	4	4	60	460	1760	2)	3)	3.0	7.8	3.8	4.8	8.7	6.8	11.0	

1) Manufacturer:	Bauer Gear Motor GmbH	2) Type of motor:	three-phase motor	3) Installation altitude above sea level (m):	1000
Commercial register number:	HRB 736269			Ambient temperature:	-20 °C to +40 °C
Address:	Eberhard-Bauer-Str. 37, 73734 Esslingen/Germany				

### Technical data of the 60 Hz motors

60 Hz

#### 4-pole IE3 motors for continuous operation S1, mains frequency 60 Hz

PN kW	Type	$n_N$	$M_N$	$I_N$	Con- nec- tion	$\cos\phi$	$\eta$	$\eta$	$\eta$	$I_A/I_N$	$M_A/M_N$	$M_S/M_N$	$M_K/M_N$	$J_{rot}$	Brake
		1/min	Nm	(460 V) A			(100%-Load) %	(75%-Load) %	(50%-Load) %						
0.12	DPE05LA4	1715	0.67	0.37	Y	0.57	71.4	68.2	61	4.4	3.7	3.6	3.9	0.000295	E003
0.12	DPE06LA4	1715	0.67	0.37	Y	0.57	70.8	67.4	60.3	4.4	3.7	3.6	3.9	0.000295	E003
0.18	DPE07LA4	1715	1	0.52	Y	0.6	73.1	70.5	64.2	4.7	3.8	3.6	3.9	0.000385	E003, E004
0.25	DPE08MA4	1745	1.37	0.65	Y	0.63	78.2	76.2	70.9	5.5	3	2.7	3.7	0.00115	ES(X)010 EH(X)010/027
0.37	DPE08LA4	1750	2	0.94	Y	0.6	81.5	79.4	74.3	6.3	3.6	3.3	4.3	0.0015	
0.55	DPE08XA4	1740	3	1.25	Y	0.67	82.9	81.7	77.9	6.2	3.4	3	3.9	0.0017	
0.75	DPE08XB4	1735	4.15	1.67	Y	0.67	85	84.6	81.7	6.4	3.6	3.1	4	0.002	ES(X)010/027 EH(X)027/040
0.75	DPE09LA4	1750	4.1	1.45	Y	0.76	83.9	82.6	78.9	7.7	3.7	3.4	4.2	0.0032	
1.1	DPE09XB4	1755	6	2.2	Y	0.73	87.4	86.4	83.5	8.7	4.2	3.8	5	0.0049	
1.5	DPE09XB4	1745	8.2	2.9	Y	0.76	87.1	86.8	84.4	7.6	3.6	3.4	4.3	0.0049	ES(X)027/040/070 EH(X)070/125
2.2	DPE11LB4	1760	11.9	3.7	Y	0.83	90.3	90	88.3	9.5	3.7	3.2	4.5	0.017	
3	DPE11LB4	1760	16.3	5.2	D	0.81	90.7	90.5	88.9	9	3.8	3.3	4.6	0.017	
4	DPE11LB4	1760	21.7	6.9	D	0.81	90.5	90.5	89.5	9.3	3.7	3	4.7	0.017	

$P_N$	Rated power
$n_N$	Guideline value for rated speed at the rotor shaft
$M_N$	Rated torque at the rotor shaft
$I_N$	Rated current (the current can be converted in inverse ratio to the voltages for the desired special voltage)
$\cos\phi$	Power factor
$\eta$	Efficiency at different loads
$I_A/I_N$	Relative starting current
$M_A/M_N$	Relative starting torque
$M_S/M_N$	Relative pull-up torque
$M_K/M_N$	Relative breakdown torque
$J_{rot}$	Mass moment of inertia of the rotor
Brake	Brake dimensioning see chapter "Motor Mounted Components-Dimensions"

The standard motor winding configuration is for 460 V / 60 Hz.

All motors are suitable for the voltage range 440...480 V or 460 V +/- 10 % if executed in insulation class F.

**Important:** Current, power factor and torque change as voltage deviates from 460 V.

See "www.bauergears.com" for more information.

## Technical data of the 60 Hz motors

60 Hz

## 4-pole motors for intermittent periodic duty (S3/S6 75 %) and 60 Hz mains frequency

$P_N$ kW	Type	$n_N$ 1/min	$M_N$ Nm	$I_N$ (460 V) A	Connection	$\cos\phi$	$I_A/I_N$	$M_A/M_N$	$M_S/M_N$	$M_K/M_N$	$J_{rot}$ kgm <sup>2</sup>	Brake
0.9	DSE08MA4	1620	5.4	2.1	Y	0.81	3.2	1.6	1.5	1.9	0.00115	ES(X)010
1.1	DSE08LA4	1660	6.3	2.4	Y	0.79	3.6	1.6	1.6	1.9	0.0015	
1.5	DSE08XA4	1660	8.4	3.1	Y	0.81	3.6	1.6	1.5	1.8	0.0017	
2	DSE09SA4	1660	11.5	3.8	Y	0.86	4.2	1.8	1.6	2	0.00245	ES(X)010 ES(X)027
2.6	DSE09LA4	1660	15.3	5	Y	0.86	4.3	1.9	1.8	2.2	0.0032	
3	DSE09XA4	1680	17	5.5	Y	0.83	4.8	2.4	2.2	2.6	0.0038	ES(X)027 ES(X)040 ES(X)070
4.5	DSE11SA4	1700	25	7.8	D	0.85	4.9	2	1.8	2.5	0.0081	
6	DSE11MA4	1700	34	10.5	D	0.86	4.7	2.2	1.8	2.4	0.0105	
7.5	DSE11LA4	1720	41.5	12.7	D	0.86	5.8	2.4	2.1	2.9	0.014	

$P_N$	Rated power
$n_N$	Guideline value for rated speed at the rotor shaft
$M_N$	Rated torque at the rotor shaft
$I_N$	Rated current (the current can be converted in inverse ratio to the voltages for the desired special voltage)
$\cos\phi$	Power factor
$I_A/I_N$	Relative starting current
$M_A/M_N$	Relative starting torque
$M_S/M_N$	Relative pull-up torque
$M_K/M_N$	Relative breakdown torque
$J_{rot}$	Mass moment of inertia of the rotor
Brake	Brake dimensioning see chapter "Motor Mounted Components-Dimensions"

The standard motor winding configuration is for 460 V / 60 Hz.

See "www.bauergears.com" for more information.

### Technical data of the 60 Hz motors

**60 Hz**

#### 4-pole motors for intermittent periodic duty (S3/S6) and 60 Hz mains frequency

$P_N$ kW	ED	Type	$n_N$ 1/min	$M_N$ Nm	$I_N$ (460 V) A	Connection	$\cos\phi$	$I_A/I_N$	$M_A/M_N$	$M_S/M_N$	$M_K/M_N$	$J_{rot}$ kgm <sup>2</sup>
0.15	15%	D04LA4	1620	0.87	0.56	Y	0.77	2.2	1.8	1.7	1.8	0.000175
0.3	15%	D05LA4	1620	1.75	0.9	Y	0.75	2.8	2.1	2	2.1	0.000295
0.3	60%	D06LA4	1620	1.75	0.9	Y	0.75	2.8	2.1	2	2.1	0.000295
0.55	60%	D07LA4	1620	3.2	1.78	Y	0.86	3.7	1.8	1.6	1.8	0.000385
0.75	60%	D08MA4	1680	4.2	1.84	Y	0.81	3.7	1.8	1.5	1.9	0.00115
1.1	60%	D08LA4	1680	6.2	2.5	Y	0.82	3.6	1.6	1.5	1.9	0.0015
1.5	60%	D09SA4	1680	8.5	3.3	Y	0.84	4.3	1.9	1.6	2.2	0.00245
2.2	60%	D09LA4	1680	12.5	4.5	Y	0.86	4.3	1.8	1.6	2.1	0.0032
3	60%	D09XA4	1680	16.6	6.2	Y	0.86	3.7	1.9	1.8	2.1	0.0038
4	60%	D11SA4	1710	22	8.1	$\Delta$	0.85	4.4	1.8	1.5	2.2	0.0081
5.5	60%	D11MA4	1710	30.5	10.7	$\Delta$	0.87	4.7	1.6	1.6	2.2	0.0105
7.5	60%	D11LA4	1710	41.5	14.6	$\Delta$	0.87	5	2	1.9	2.3	0.014

$P_N$	Rated power
ED	Duty cycle
$n_N$	Guideline value for rated speed at the rotor shaft
$M_N$	Rated torque at the rotor shaft
$I_N$	Rated current (the current can be converted in inverse ratio to the voltages for the desired special voltage)
$\cos\phi$	Power factor
$I_A/I_N$	Relative starting current
$M_A/M_N$	Relative starting torque
$M_S/M_N$	Relative pull-up torque
$M_K/M_N$	Relative breakdown torque
$J_{rot}$	Mass moment of inertia of the rotor

The standard motor winding configuration is for 460 V / 60 Hz.

See "www.bauergears.com" for additional information.

## Technical data of the 60 Hz motors

60 Hz

4/2-pole motors  $\Delta/YY$  for continuous operation S1, line frequency 60 Hz

$P_N$ kW	Type	$n_N$ 1/min	$M_N$ Nm	$I_N$ (460 V) A	$\cos\phi$	$I_A/I_N$	$M_A/M_N$	$M_S/M_N$	$M_K/M_N$	$J_{rot}$ kgm <sup>2</sup>
0.03/0.06	D04LA42	1620/3240	0.160/0.170	0.200/0.230	0.56/0.67	2.4/3.4	3.8/3.4	3.8/3.4	4.0/3.7	0.000175
0.04/0.08	D04LA42	1620/3240	0.230/0.230	0.230/0.260	0.60/0.75	2.2/3.1	3.3/2.3	3.3/2.3	3.7/2.4	0.000175
0.06/0.12	D05LA42	1620/3240	0.350/0.350	0.420/0.420	0.50/0.75	3.1/3.6	3.4/2.2	3.3/2.1	4.2/2.9	0.000295
0.08/0.16	D05LA42	1620/3240	0.470/0.470	0.460/0.460	0.55/0.75	3.1/3.6	3.1/2.0	3.0/1.9	3.8/2.5	0.000295
0.06/0.12	D06LA42	1620/3240	0.350/0.350	0.420/0.420	0.50/0.75	3.1/3.6	3.4/2.2	3.3/2.1	4.2/2.9	0.000295
0.08/0.16	D06LA42	1620/3240	0.470/0.470	0.46/0.460	0.55/0.75	3.1/3.6	3.1/2.0	3.0/1.9	3.8/2.5	0.000295
0.11/0.22	D06LA42	1620/3240	0.64/0.64	0.63/0.63	0.55/0.75	3.1/3.6	3.1/2.0	3.0/1.9	3.8/2.5	0.000295
0.16/0.32	D06LA42	1620/3240	0.94/0.94	0.82/0.82	0.57/0.80	3.1/3.6	2.8/1.9	2.7/1.8	3.4/2.3	0.000295
0.2/0.4	D07LA42	1680/3360	1.12/1.14	1.04/1.08	0.58/0.81	3.2/3.9	3.1/1.8	3.0/1.5	3.3/2.2	0.000385
0.28/0.56	D08MA42	1680/3360	1.58/1.58	1.10/1.60	0.61/0.81	3.7/3.2	2.5/1.7	2.5/1.5	3.3/2.1	0.00115
0.4/0.8	D08LA42	1680/3360	2.2/2.2	1.40/1.74	0.6/0.90	5.1/5.6	3.0/2.0	2.6/1.9	3.4/2.3	0.0015
0.5/1.0	D09SA42	1680/3360	2.8/2.8	1.60/2.6	0.71/0.91	5.5/4.6	3.4/2.2	3.4/2.2	4.2/2.6	0.00245
0.7/1.4	D09SA42	1680/3360	3.9/3.9	1.93/3.1	0.71/0.93	5.1/4.5	2.8/1.8	2.8/1.8	3.4/2.2	0.00245
1.0/2.0	D09LA42	1680/3360	5.6/5.6	2.8/4.3	0.72/0.94	5.1/4.5	2.8/1.8	2.8/1.8	3.4/2.2	0.0032
1.2/2.4	D09XA42	1680/3360	6.8/6.7	3.4/5.2	0.65/0.87	6.8/3.3	2.7/2.0	2.7/2.0	3.4/2.5	0.0038
1.4/2.8	D11SA42	1710/3420	7.8/7.8	3.3/5.7	0.74/0.90	7.0/4.9	3.3/1.9	2.8/1.6	4.5/3.1	0.0081
2.0/4.0	D11MA42	1710/3420	11.2/11.1	5.1/8.4	0.70/0.90	7.3/5.9	3.4/2.3	3.0/1.8	4.1/2.8	0.0105
2.5/5.0	D11LA42	1710/3420	14/14	5.0/9.1	0.79/0.92	6.5/5.0	3.1/2.0	3.0/1.9	4.1/2.8	0.014

$P_N$	Rated power
$n_N$	Guideline value for rated speed at the rotor shaft
$M_N$	Rated torque at the rotor shaft
$I_N$	Rated current (the current can be converted in inverse ratio to the voltages for the desired special voltage)
$\cos\phi$	Power factor
$I_A/I_N$	Relative starting current
$M_A/M_N$	Relative starting torque
$M_S/M_N$	Relative pull-up torque
$M_K/M_N$	Relative breakdown torque
$J_{rot}$	Mass moment of inertia of the rotor

The standard motor winding configuration is for 460 V / 60 Hz.

See "www.bauergears.com" for additional information.

### Technical data of the 60 Hz motors

<b>60 Hz</b>
--------------

#### 8/4-pole motors Δ/YY for continuous operation S1, line frequency 60 Hz

$P_N$ kW	Type	$n_N$ 1/min	$M_N$ Nm	$I_N$ (460 V) A	$\cos\varphi$	$I_A/I_N$	$M_A/M_N$	$M_S/M_N$	$M_K/M_N$	$J_{rot}$ kgm <sup>2</sup>
0.03/0.06	D05LA84	810/1620	0.340/0.350	0.280/0.260	0.52/0.71	1.8/2.8	3.0/2.1	1.8/1.9	1.8/1.9	0.000295
0.03/0.06	D06LA84	810/1620	0.340/0.350	0.280/0.260	0.52/0.71	1.8/2.8	3.0/2.1	1.8/1.9	1.8/1.9	0.000295
0.04/0.08	D06LA84	810/1620	0.450/0.460	0.440/0.370	0.52/0.66	1.5/2.4	2.9/2.3	1.8/1.9	1.8/1.9	0.000295
0.06/0.12	D07LA84	810/1620	0.70/0.70	0.65/0.55	0.52/0.66	1.9/3.1	3.5/1.9	3.5/1.7	3.6/2.3	0.000385
0.06/0.12	D08LA84	840/1680	0.67/0.67	0.460/0.460	0.61/0.83	3.1/4.1	3.4/2.5	3.4/2.5	3.9/3.2	0.0025
0.08/0.16	D08LA84	840/1680	0.90/0.90	0.57/0.57	0.61/0.83	3.1/4.1	3.3/2.4	3.3/2.4	3.9/3.3	0.0025
0.11/0.22	D08LA84	840/1680	1.24/1.25	0.74/0.74	0.61/0.83	3.1/4.1	3.1/2.3	3.1/2.3	3.7/3.1	0.0025
0.14/0.28	D08LA84	840/1680	1.58/1.59	0.92/0.92	0.61/0.83	3.1/4.1	3.1/2.3	3.1/2.3	3.7/3.1	0.0025
0.2/0.4	D08LA84	840/1680	2.2/2.2	1.05/1.20	0.55/0.77	3.1/4.1	2.5/1.9	2.5/1.9	3.0/2.5	0.0025
0.25/0.5	D09XC84	840/1680	2.8/2.8	1.28/1.28	0.48/0.77	3.2/5.5	3.0/2.2	3.0/2.3	3.4/3.0	0.006
0.28/0.56	D09XC84	840/1680	3.1/3.1	1.29/1.38	0.57/0.80	3.2/5.4	2.7/2.0	2.7/2.1	3.1/2.7	0.006
0.4/0.8	D09XC84	840/1680	4.5/4.5	1.80/2.2	0.55/0.79	3.1/4.6	2.5/1.9	2.5/2.0	3.0/2.5	0.006
0.5/1.0	D09XC84	840/1680	5.6/5.6	2.2/2.4	0.55/0.81	2.9/4.4	2.4/1.8	2.4/1.8	2.8/2.4	0.006
0.8/1.6	D11LC84	850/1710	8.9/8.9	2.8/3.8	0.63/0.88	3.8/4.7	2.4/2.1	2.4/1.9	3.1/3.0	0.0215
1.1/2.2	D11LC84	850/1710	12.2/12.2	3.7/4.5	0.58/0.85	4.3/6.2	2.5/2.3	2.5/1.9	3.0/2.7	0.0215
1.6/3.2	D11LC84	850/1710	17.9/17.9	5.5/7.0	0.59/0.84	4.1/5.6	2.4/2.0	2.3/1.6	2.8/2.5	0.0215

$P_N$	Rated power
$n_N$	Guideline value for rated speed at the rotor shaft
$M_N$	Rated torque at the rotor shaft
$I_N$	Rated current (the current can be converted in inverse ratio to the voltages for the desired special voltage)
$\cos\varphi$	Power factor
$I_A/I_N$	Relative starting current
$M_A/M_N$	Relative starting torque
$M_S/M_N$	Relative pull-up torque
$M_K/M_N$	Relative breakdown torque
$J_{rot}$	Mass moment of inertia of the rotor

The standard motor winding configuration is for 460 V / 60 Hz.

See "www.bauergears.com" for additional information.



## Technical data of the 60 Hz motors

60 Hz

## 8/2-pole Y/Y motors for intermittent periodic duty S3 25/75 % and 60 Hz mains frequency

$P_N$	ED	Type	$n_N$	$M_N$	$I_N$	$\cos\phi$	$I_A/I_N$	$M_A/M_N$	$M_S/M_N$	$M_K/M_N$	$J_{rot}$
kW			1/min	Nm	(460 V) A						kgm <sup>2</sup>
0.04/0.16	25/75 %	D05LA82	680/2700	0.56/0.56	0.400/0.80	0.63/0.75	1.6/3.2	1.9/2.2	1.9/2.1	2.0/2.3	0.000295
0.05/0.20	25/75 %	D06LA82	680/2700	0.70/0.70	0.51/1.02	0.63/0.75	1.4/2.8	1.7/2.0	1.7/1.9	1.8/2.1	0.000295
0.063/0.25	25/75 %	D07LA82	650/2840	0.87/0.87	0.60/1.20	0.69/0.62	1.4/2.6	1.6/1.4	1.6/1.4	1.8/2.7	0.000385
0.071/0.28	25/75 %	D07LA82	650/2840	0.99/0.98	0.65/1.40	0.69/0.68	1.4/2.6	1.5/1.3	1.5/1.3	1.7/2.6	0.000385
0.063/0.25	25/75 %	D08LA82	700/2800	0.85/0.85	0.55/0.70	0.55/0.87	2.8/4.0	2.4/2.6	2.4/2.5	2.8/3.0	0.0015
0.09/0.36	25/75 %	D08LA82	700/2800	1.22/1.22	0.70/1.05	0.60/0.92	2.9/4.5	2.0/2.6	2.0/2.5	2.4/2.9	0.0015
0.12/0.5	25/75 %	D08LA82	700/2800	1.70/1.70	0.95/1.43	0.60/0.92	2.9/4.5	2.0/2.6	2.0/2.5	2.4/2.9	0.0015
0.16/0.63	25/75 %	D08LA82	700/2800	2.1/2.1	1.20/1.45	0.63/0.90	2.0/4.6	1.8/2.1	1.8/2.0	2.2/2.4	0.0015
0.25/1.0	25/75 %	D09XA82	700/2800	3.4/3.4	1.30/2.3	0.62/0.90	2.2/5.2	1.9/2.3	1.9/2.3	2.0/2.6	0.0038
0.3/1.4	25/75 %	D09XA82	700/2800	4.9/4.8	2.1/3.3	0.57/0.87	2.0/4.5	1.9/2.1	1.9/2.1	2.0/2.4	0.0038
0.45/1.8	25/75 %	D09XA82	700/2800	6.1/6.1	2.4/4.3	0.65/0.89	2.0/4.3	1.7/2.0	1.7/2.0	2.0/2.5	0.0038
0.56/2.2	25/75 %	D11LA82	710/2840	7.5/7.3	2.3/4.7	0.60/0.94	3.2/4.9	1.9/2.9	1.9/2.4	2.2/2.9	0.014
0.71/2.8	25/75 %	D11LA82	710/2840	9.5/9.4	2.8/5.6	0.58/0.94	2.5/4.7	1.9/2.3	1.9/2.0	2.1/2.4	0.014
0.90/3.6	25/75 %	D11LA82	710/2840	12.1/12.1	3.5/7.9	0.58/0.94	2.5/4.5	1.8/2.0	1.8/1.8	2.0/2.1	0.014

$P_N$	Rated power
ED	Duty cycle
$n_N$	Guideline value for rated speed at the rotor shaft
$M_N$	Rated torque at the rotor shaft
$I_N$	Rated current (the current can be converted in inverse ratio to the voltages for the desired special voltage)
$\cos\phi$	Power factor
$I_A/I_N$	Relative starting current
$M_A/M_N$	Relative starting torque
$M_S/M_N$	Relative pull-up torque
$M_K/M_N$	Relative breakdown torque
$J_{rot}$	Mass moment of inertia of the rotor

The standard motor winding configuration is for 460 V / 60 Hz.

See "www.bauergears.com" for additional information.

### Technical data of the 60 Hz motors

**60 Hz**

#### 12/2-pole motors Y/Y for intermittent periodic duty S3-25/75 %, line frequency 60 Hz

$P_N$ kW	ED	Type	$n_N$ 1/min	$M_N$ Nm	$I_N$ (460 V) A	$\cos\phi$	$I_A/I_N$	$M_A/M_N$	$M_S/M_N$	$M_K/M_N$	$J_{rot}$ kgm <sup>2</sup>
0.045/0.28	25/75 %	D08LA122	560/3360	0.76/0.79	0.51/0.79	0.70/0.90	1.5/4.9	2.1/2.7	2.1/2.7	2.1/3.0	0.0015
0.063/0.40	25/75 %	D08LA122	560/3360	1.07/1.13	0.61/1.02	0.70/0.90	1.5/4.9	1.9/2.4	1.9/2.4	1.9/2.7	0.0015
0.09/0.56	25/75 %	D08LA122	560/3360	1.54/1.59	0.95/1.35	0.63/0.89	1.5/4.5	1.9/2.3	1.9/2.5	2.0/2.6	0.0015
0.11/0.71	25/75 %	D09XA122	560/3360	1.88/2.0	1.00/1.50	0.59/0.88	1.6/6.0	1.9/3.0	1.9/2.9	2.0/3.6	0.0038
0.16/1.0	25/75 %	D09XA122	560/3360	2.7/2.8	1.56/2.2	0.62/0.89	1.6/6.0	2.0/2.9	2.0/2.7	2.0/3.6	0.0038
0.2/1.25	25/75 %	D09XA122	560/3360	3.4/3.5	1.85/2.8	0.62/0.89	1.6/5.5	1.9/2.6	1.9/2.5	1.9/3.4	0.0038
0.25/1.6	25/75 %	D11LA122	560/3420	4.2/4.4	2.1/3.1	0.53/0.95	1.8/5.4	1.9/2.8	1.9/2.6	2.2/3.1	0.014
0.32/2.0	25/75 %	D11LA122	560/3420	5.4/5.5	2.7/3.6	0.53/0.94	1.8/5.1	1.9/2.7	1.9/2.4	2.2/3.0	0.014
0.45/2.8	25/75 %	D11LA122	560/3420	7.6/7.8	3.8/5.1	0.52/0.94	1.8/5.1	1.6/2.5	1.6/2.2	2.0/2.6	0.014

$P_N$	Rated power
ED	Duty cycle
$n_N$	Guideline value for rated speed at the rotor shaft
$M_N$	Rated torque at the rotor shaft
$I_N$	Rated current (the current can be converted in inverse ratio to the voltages for the desired special voltage)
$\cos\phi$	Power factor
$I_A/I_N$	Relative starting current
$M_A/M_N$	Relative starting torque
$M_S/M_N$	Relative pull-up torque
$M_K/M_N$	Relative breakdown torque
$J_{rot}$	Mass moment of inertia of the rotor

The standard motor winding configuration is for 460 V / 60 Hz.

See "www.bauergears.com" for additional information.

## Operation with frequency converter, 50 Hz

50 Hz

## IE1 Motor torques for frequency-converter range 5 Hz - 70 Hz, line frequency 50 Hz

P <sub>N</sub> kW	Type	Connec- tion	5 Hz	10 Hz	20 Hz	30 Hz	50 Hz	60 Hz	70 Hz	5 Hz	10 Hz	20 Hz	30 Hz	50 Hz	60 Hz	70 Hz
			M Nm	M Nm	M Nm	M Nm	M Nm	M Nm	M Nm	M Nm	M Nm	I A	I A	I A	I A	I A
0.03	D04LA4	Y	0.125	0.155	0.185	0.205	0.21	0.21	0.18	0.19	0.193	0.198	0.2	0.2	0.23	0.23
0.04	D04LA4	Y	0.165	0.21	0.25	0.275	0.28	0.275	0.205	0.19	0.193	0.198	0.2	0.2	0.23	0.2
0.06	D04LA4	Y	0.25	0.315	0.375	0.41	0.42	0.42	0.32	0.29	0.295	0.3	0.3	0.3	0.34	0.305
0.09	D04LA4	Y	0.375	0.47	0.56	0.62	0.63	0.63	0.52	0.435	0.44	0.45	0.45	0.45	0.51	0.495
0.11	D04LA4	Y	0.465	0.58	0.7	0.77	0.78	0.67	0.495	0.41	0.425	0.44	0.45	0.45	0.45	0.435
0.06	D05LA4	Y	0.25	0.315	0.375	0.41	0.42	0.42	0.36	0.3	0.315	0.34	0.35	0.35	0.395	0.4
0.09	D05LA4	Y	0.375	0.47	0.56	0.62	0.63	0.63	0.54	0.355	0.365	0.375	0.38	0.38	0.43	0.43
0.06	D06LA4	Y	0.25	0.315	0.375	0.41	0.42	0.42	0.36	0.3	0.315	0.34	0.35	0.35	0.395	0.4
0.09	D06LA4	Y	0.375	0.47	0.56	0.62	0.63	0.63	0.54	0.355	0.365	0.375	0.38	0.38	0.43	0.43
0.12	DSE04LA4	Y	0.52	0.65	0.78	0.85	0.87	0.67	0.495	0.45	0.45	0.45	0.45	0.45	0.45	0.45
0.18	DSE05LA4	Y	0.76	0.96	1.15	1.26	1.28	1.28	0.97	0.6	0.61	0.63	0.63	0.63	0.72	0.64
0.2	DSE05LA4	Y	0.85	1.06	1.27	1.4	1.42	1.35	0.99	0.62	0.63	0.65	0.66	0.66	0.72	0.66
0.25	DSE05LA4	Y	1.05	1.31	1.57	1.72	1.75	1.59	1.17	0.86	0.87	0.87	0.87	0.87	0.9	0.87
0.18	DSE06LA4	Y	0.76	0.96	1.15	1.26	1.28	1.28	1.02	0.6	0.61	0.63	0.63	0.63	0.72	0.67
0.2	DSE06LA4	Y	0.85	1.06	1.27	1.4	1.42	1.35	0.99	0.61	0.63	0.64	0.65	0.65	0.71	0.65
0.25	DSE06LA4	Y	1.05	1.31	1.57	1.72	1.75	1.59	1.17	0.86	0.87	0.87	0.87	0.87	0.9	0.87
0.37	DSE07LA4	Y	1.59	1.98	2.3	2.6	2.6	2.5	1.85	1.13	1.14	1.15	1.15	1.15	1.24	1.15
0.55	DSE08MA4	Y	2.2	2.8	3.3	3.7	3.8	3.8	2.8	1.29	1.35	1.41	1.45	1.45	1.64	1.47
0.75	DSE08LA4	Y	3	3.8	4.5	5	5.1	5.1	3.9	1.7	1.79	1.89	1.95	1.95	2.2	1.97
1.1	DSE08XA4	Y	4.5	5.6	6.7	7.4	7.5	7.1	5.2	2.5	2.6	2.8	2.8	2.8	3.1	2.8
1.1	DSE09SA4	Y	4.5	5.6	6.7	7.4	7.5	7.5	6.4	2.2	2.4	2.5	2.6	2.6	3	3
1.5	DSE09LA4	Y	6	7.5	9	9.9	10.1	10.1	8.6	3	3.2	3.4	3.5	3.5	4	4
2.2	DSE09XA4	Y	9	11.2	13.5	14.8	15	15	12.4	3.9	4.2	4.7	4.9	4.9	5.6	5.4
3	DSE11SA4	Y	12	15	18	19.7	20	20	17.1	5.1	5.5	6.1	6.4	6.4	7.3	7.3
4	DSE11MA4	Y	16.2	20	24	26.5	27	27	23	6.4	7.1	7.9	8.4	8.4	9.5	9.5
5.5	DSE11LA4	Y	22	27.5	33	36.5	37	37	31.5	8.2	9.3	10.5	11.2	11.3	12.8	12.8

P<sub>N</sub> Rated power

M Permissible load torque (S1-100 %) at the rotor shaft by operation with a frequency inverter

I Load current for operation with frequency inverter

Field weakening for frequencies above 50 Hz, winding for standard voltage **400 V Y / 50 Hz**, Temperature Class F ation with frequency inverter

Motors with standard windings can be switched from Y- to Δ- circuit for operation with a converter having a single-phase mains connection. This has no effect on the torques and frequencies as listed in the table above. As regards the choice of converter, however, note that currents are higher than those of the Y-circuit by a factor of 1.73.

The load currents in the table are guideline values for selecting the size of frequency inverter. Load current is lower if the load torque is below the values permitted for 30-70 Hz and the frequency inverter used is of the high-grade type. This means that a smaller inverter can sometimes be used, particularly in conjunction with large motors.

Operation with frequency converter, 50 Hz

**50 Hz**

**IE1 Motor torques for frequency-converter range 5 Hz - 100 Hz, line frequency 50 Hz**

P <sub>N</sub> kW	Type	Connection	5 Hz	8.7 Hz	10 Hz	20 Hz	87 Hz	100 Hz	5 Hz	8.7 Hz	10 Hz	20 Hz	87 Hz	100 Hz
			M Nm	M Nm	M Nm	M Nm	M Nm	M Nm	M Nm	I A	I A	I A	I A	I A
0.03	D04LA4	D	0.125	0.15	0.155	0.185	0.21	0.21	0.33	0.335	0.335	0.345	0.35	0.38
0.04	D04LA4	D	0.165	0.2	0.21	0.25	0.28	0.28	0.33	0.335	0.335	0.345	0.35	0.38
0.06	D04LA4	D	0.25	0.3	0.315	0.375	0.42	0.42	0.51	0.51	0.51	0.52	0.52	0.57
0.09	D04LA4	D	0.375	0.45	0.47	0.56	0.63	0.63	0.76	0.76	0.77	0.78	0.78	0.86
0.11	D04LA4	D	0.465	0.56	0.58	0.7	0.78	0.73	0.71	0.73	0.73	0.76	0.78	0.81
0.06	D05LA4	D	0.25	0.3	0.315	0.375	0.42	0.42	0.52	0.54	0.55	0.59	0.61	0.67
0.09	D05LA4	D	0.375	0.45	0.47	0.56	0.63	0.63	0.62	0.63	0.63	0.65	0.66	0.73
0.09	D05LA4	D	0.375	0.45	0.47	0.56	0.63	0.63	0.62	0.63	0.63	0.65	0.66	0.73
0.06	D06LA4	D	0.25	0.3	0.315	0.375	0.42	0.42	0.52	0.54	0.55	0.59	0.61	0.67
0.09	D06LA4	D	0.375	0.45	0.47	0.56	0.63	0.63	0.62	0.63	0.63	0.65	0.66	0.73
0.12	DSE04LA4	D	0.52	0.62	0.65	0.78	0.87	0.74	0.78	0.78	0.78	0.78	0.78	0.78
0.18	DSE05LA4	D	0.76	0.92	0.96	1.15	1.28	1.28	1.04	1.06	1.06	1.08	1.1	1.2
0.2	DSE05LA4	D	0.85	1.02	1.06	1.27	1.42	1.42	1.06	1.09	1.09	1.13	1.15	1.26
0.25	DSE05LA4	D	1.05	1.25	1.31	1.57	1.75	1.73	1.49	1.5	1.5	1.51	1.51	1.65
0.18	DSE06LA4	D	0.76	0.92	0.96	1.15	1.28	1.28	1.04	1.06	1.06	1.08	1.1	1.2
0.2	DSE06LA4	D	0.85	1.02	1.06	1.27	1.42	1.42	1.06	1.08	1.08	1.11	1.13	1.24
0.25	DSE06LA4	D	1.05	1.25	1.31	1.57	1.75	1.73	1.49	1.5	1.5	1.51	1.51	1.65
0.37	DSE07LA4	D	1.59	1.9	1.98	2.3	2.6	2.6	1.95	1.96	1.97	1.98	2	2.2
0.55	DSE08MA4	D	2.2	2.7	2.8	3.3	3.8	3.8	2.2	2.4	2.4	2.5	2.6	2.8
0.75	DSE08LA4	D	3	3.6	3.8	4.5	5.1	5.1	3	3.1	3.1	3.3	3.4	3.8
1.1	DSE08XA4	D	4.5	5.4	5.6	6.7	7.5	7.5	4.3	4.5	4.5	4.7	4.9	5.4
1.1	DSE09SA4	D	4.5	5.4	5.6	6.7	7.5	7.5	3.8	4	4.1	4.4	4.5	5
1.5	DSE09LA4	D	6	7.2	7.5	9	10.1	10.1	5.1	5.4	5.4	5.8	6.1	6.7
2.2	DSE09XA4	D	9	10.7	11.2	13.5	15	15	6.8	7.3	7.4	8.1	8.5	9.4
3	DSE11SA4	D	12	14.3	15	18	20	20	8.7	9.4	9.6	10.5	11.1	12.2
4	DSE11MA4	D	16.2	19.4	20	24	27	27	11	12	12.2	13.6	14.6	16
5.5	DSE11LA4	D	22	26.5	27.5	33	37	37	14.2	15.7	16.1	18.2	19.6	21.5

P<sub>N</sub> Rated power

M Permissible load torque (S1-100 %) at the rotor shaft by operation with a frequency inverter

I Load current for operation with frequency inverter

Field weakening for frequencies above 87 Hz, winding for **230 V Δ/ 50 Hz** (U<sub>max</sub> = 400 V Δ/87 Hz), Temperature Class F.

The load currents in the table are guideline values for selecting the size of frequency inverter. Load current is lower if the load torque is below the values permitted for 30-100 Hz and the frequency inverter used is of the high-grade type. This means that a smaller inverter can sometimes be used, particularly in conjunction with large motors.

## Operation with frequency converter, 50 Hz

50 Hz

## IE2 Motor torques for frequency-converter range 5 Hz - 70 Hz, line frequency 50 Hz

P <sub>N</sub> kW	Type	Connec- tion	5 Hz	10 Hz	20 Hz	30 Hz	50 Hz	60 Hz	70 Hz	5 Hz	10 Hz	20 Hz	30 Hz	50 Hz	60 Hz	70 Hz
			M Nm	M Nm	M Nm	M Nm	M Nm	M Nm	M Nm	M Nm	M Nm	I A	I A	I A	I A	I A
0.12	DHE05LA4	Y	0.49	0.61	0.73	0.81	0.82	0.82	0.65	0.36	0.37	0.385	0.39	0.39	0.44	0.415
0.18	DHE05LA4	Y	0.75	0.93	1.12	1.23	1.25	1.25	1.03	0.53	0.54	0.56	0.57	0.57	0.65	0.63
0.12	DHE06LA4	Y	0.495	0.62	0.74	0.81	0.83	0.83	0.66	0.36	0.37	0.385	0.39	0.39	0.44	0.415
0.18	DHE06LA4	Y	0.75	0.93	1.12	1.23	1.25	1.25	1.03	0.54	0.55	0.57	0.58	0.58	0.66	0.64
0.25	DHE07LA4	Y	1.04	1.3	1.56	1.71	1.74	1.74	1.49	0.7	0.72	0.75	0.76	0.76	0.86	0.86
0.3	DHE07LA4	Y	1.26	1.57	1.89	2	2.1	2.1	1.8	0.82	0.85	0.88	0.9	0.9	1.02	1.02
0.37	DHE08MA4	Y	1.47	1.83	2.2	2.4	2.4	2.4	2.1	0.99	1.03	1.07	1.1	1.1	1.25	1.25
0.55	DHE08LA4	Y	2.2	2.8	3.3	3.6	3.7	3.7	3	1.15	1.23	1.32	1.38	1.38	1.56	1.51
0.75	DHE08XA4	Y	3	3.8	4.5	4.9	5	5	4.2	1.6	1.7	1.81	1.88	1.88	2.2	2.2
0.75	DHE09SA4	Y	3	3.8	4.5	4.9	5	5	4.2	1.54	1.63	1.73	1.8	1.8	2.1	2.1
1.1	DHE09LA4	Y	4.3	5.4	6.5	7.2	7.3	7.3	6.2	2.1	2.2	2.5	2.6	2.6	2.9	2.9
1.5	DHE09XA4	Y	5.9	7.4	8.9	9.8	9.9	9.9	8.5	2.7	2.9	3.2	3.4	3.4	3.8	3.8
2.2	DHE09XA4C	Y	8.7	10.8	13	14.3	14.5	14.5	12.4	3.8	4.2	4.5	4.8	4.8	5.4	5.4
2.2	DHE09XB4	Y	8.8	11.1	13.3	14.6	14.8	14.8	12.6	3.7	4	4.5	4.7	4.7	5.4	5.4
2.2	DHE11SA4	Y	8.7	10.8	13	14.3	14.5	14.5	12.4	3.6	3.9	4.4	4.6	4.6	5.2	5.3
3	DHE11MA4	Y	12	15	18	19.7	20	20	17.1	4.9	5.4	5.9	6.3	6.3	7.2	7.2
4	DHE11LA4	Y	15.9	19.8	23.5	26	26.5	26.5	22.5	6.9	7.4	8	8.4	8.4	9.5	9.5
5.5	DHE11LA4C	Y	21.5	27	32	35.5	36	36	30.5	8.2	9.2	10.3	11	11	12.5	12.5
5.5	DHE11LB4	Y	21.5	27	32	35.5	36	36	30.5	8.3	9.2	10.3	11	11	12.5	12.5

P<sub>N</sub> Rated power

M Permissible load torque (S1-100 %) at the rotor shaft by operation with a frequency inverter

I Load current for operation with frequency inverter

Field weakening for frequencies above 50 Hz, winding for standard voltage **400 V Y / 50 Hz**, Temperature Class F.

Motors with standard windings can be switched from Y- to Δ- circuit for operation with a converter having a single-phase mains connection. This has no effect on the torques and frequencies as listed in the table above. As regards the choice of converter, however, note that currents are higher than those of the Y-circuit by a factor of 1.73.

The load currents in the table are guideline values for selecting the size of frequency converter. Load current is lower if the load torque is below the values permitted for 30-70 Hz and the frequency inverter used is of the high-grade type. This means that a smaller inverter can sometimes be used, particularly in conjunction with large motors.

Operation with frequency converter, 50 Hz

50 Hz

IE2 Motor torques for frequency-converter range 5 Hz - 100 Hz, line frequency 50 Hz

P <sub>N</sub> kW	Type	Con- nec- tion	5 Hz M Nm	8.7 Hz M Nm	10 Hz M Nm	20 Hz M Nm	87 Hz M Nm	100 Hz M Nm	5 Hz I A	8.7 Hz I A	10 Hz I A	20 Hz I A	87 Hz I A	100 Hz I A
0.12	DHE05LA4	D	0.49	0.59	0.61	0.73	0.82	0.82	0.62	0.64	0.64	0.67	0.68	0.75
0.18	DHE05LA4	D	0.75	0.89	0.93	1.12	1.25	1.25	0.91	0.93	0.94	0.97	0.99	1.09
0.12	DHE06LA4	D	0.495	0.59	0.62	0.74	0.83	0.83	0.62	0.64	0.64	0.67	0.68	0.75
0.18	DHE06LA4	D	0.75	0.89	0.93	1.12	1.25	1.25	0.93	0.95	0.95	0.99	1.01	1.11
0.25	DHE07LA4	D	1.04	1.25	1.3	1.56	1.74	1.74	1.2	1.23	1.24	1.29	1.32	1.45
0.3	DHE07LA4	D	1.26	1.51	1.57	1.89	2.1	2.1	1.42	1.46	1.47	1.52	1.56	1.71
0.37	DHE08MA4	D	1.47	1.76	1.83	2.2	2.4	2.4	1.72	1.77	1.78	1.86	1.91	2.1
0.55	DHE08LA4	D	2.2	2.6	2.8	3.3	3.7	3.7	1.99	2.1	2.2	2.3	2.4	2.7
0.75	DHE08XA4	D	3	3.6	3.8	4.5	5	5	2.8	2.9	3	3.2	3.3	3.6
0.75	DHE09SA4	D	3	3.6	3.8	4.5	5	5	2.7	2.8	2.8	3	3.2	3.5
1.1	DHE09LA4	D	4.3	5.2	5.4	6.5	7.3	7.3	3.6	3.8	3.9	4.2	4.5	4.9
1.5	DHE09XA4	D	5.9	7.1	7.4	8.9	9.9	9.9	4.6	5	5.1	5.5	5.9	6.4
2.2	DHE09XA4C	D	8.7	10.4	10.8	13	14.5	14.5	6.7	7.1	7.2	7.8	8.3	9.1
2.2	DHE09XB4	D	8.8	10.6	11.1	13.3	14.8	14.8	6.4	6.9	7	7.7	8.2	9
2.2	DHE11SA4	D	8.7	10.4	10.8	13	14.5	14.5	6.2	6.7	6.8	7.5	8	8.8
3	DHE11MA4	D	12	14.3	15	18	20	20	8.4	9.1	9.3	10.3	11	12
4	DHE11LA4	D	15.9	19	19.8	23.5	26.5	26.5	11.9	12.6	12.8	13.9	14.6	16
5.5	DHE11LA4C	D	21.5	25.5	27	32	36	36	14.2	15.6	15.9	17.8	19.1	21
5.5	DHE11LB4	D	21.5	25.5	27	32	36	36	14.3	15.6	15.9	17.8	19.1	21

P<sub>N</sub> Rated power

M Permissible load torque (S1-100 %) at the rotor shaft by operation with a frequency inverter

I Load current for operation with frequency inverter

Field weakening for frequencies above 87 Hz, winding for **230 V Δ/ 50 Hz** (U<sub>max</sub> = 400 V Δ/87 Hz), Temperature Class F.

The load currents in the table are guideline values for selecting the size of frequency inverter. Load current is lower if the load torque is below the values permitted for 30-100 Hz and the frequency inverter used is of the high-grade type. This means that a smaller inverter can sometimes be used, particularly in conjunction with large motors.

## Operation with frequency converter, 50 Hz

50 Hz

## IE3 Motor torques for frequency-converter range 5 Hz - 70 Hz. line frequency 50 Hz

P kW	Type	Con- nec- tion	5 Hz	10 Hz	20 Hz	30 Hz	50 Hz	60 Hz	70 Hz	5 Hz	10 Hz	20 Hz	30 Hz	50 Hz	60 Hz	70 Hz
			M Nm	M Nm	M Nm	M Nm	M Nm	M Nm	M Nm	M Nm	I A	I A	I A	I A	I A	I A
0.12	DPE05LA4	Y	0.49	0.61	0.73	0.81	0.82	0.82	0.7	0.37	0.38	0.395	0.4	0.4	0.455	0.455
0.12	DPE06LA4	Y	0.49	0.61	0.73	0.81	0.82	0.82	0.7	0.38	0.39	0.405	0.41	0.41	0.465	0.465
0.18	DPE07LA4	Y	0.73	0.92	1.1	1.21	1.23	1.23	1.05	0.52	0.53	0.55	0.56	0.56	0.64	0.64
0.25	DPE08MA4	Y	0.99	1.24	1.49	1.63	1.66	1.66	1.42	0.62	0.65	0.69	0.71	0.71	0.81	0.81
0.37	DPE08LA4	Y	1.47	1.83	2.2	2.4	2.4	2.4	2.1	0.92	0.96	1	1.03	1.03	1.17	1.17
0.55	DPE08XA4	Y	2.1	2.7	3.2	3.6	3.6	3.6	3.1	1.19	1.26	1.35	1.4	1.4	1.58	1.59
0.75	DPE08XB4	Y	3	3.8	4.5	4.9	5	5	4.2	1.57	1.67	1.78	1.85	1.86	2.1	2.2
0.75	DPE09LA4	Y	3	3.8	4.5	4.9	5	5	4.2	1.3	1.43	1.57	1.66	1.67	1.89	1.89
1.1	DPE09XA4	Y	4.3	5.4	6.5	7.2	7.3	7.3	6.2	1.9	2.1	2.3	2.4	2.4	2.8	2.8
1.5	DPE09XB4	Y	6	7.5	9	9.8	10	10	8.5	2.6	2.8	3.1	3.2	3.2	3.7	3.7
2.2	DPE09XB4C	Y	8.7	10.8	13	14.3	14.5	14.5	12.4	3.8	4.1	4.5	4.7	4.7	5.4	5.4
2.2	DPE11MA4	Y	8.7	10.8	13	14.3	14.5	14.5	12.4	3.5	3.9	4.3	4.6	4.6	5.2	5.3
3	DPE11LA4	Y	11.8	14.7	17.7	19.4	19.7	19.7	16.8	4.8	5.3	5.9	6.2	6.2	7	7.1
4	DPE11LB4	Y	15.9	19.8	23.5	26	26.5	26.5	22.5	5.7	6.4	7.3	7.8	7.8	8.8	8.9
5.5	DPE11LB4C	Y	21.5	27	32	35.5	36	36	30.5	8.3	9.2	10.3	11	11	12.5	12.5

$P_N$  Rated power

M Permissible load torque (S1-100 %) at the rotor shaft by operation with a frequency inverter

I Load current for operation with frequency inverter

Field weakening for frequencies above 50 Hz, winding for standard voltage **400 V Y / 50 Hz**, Temperature Class F.

Motors with standard windings can be switched from Y- to  $\Delta$ - circuit for operation with a converter having a single-phase mains connection. This has no effect on the torques and frequencies as listed in the table above. As regards the choice of converter, however, note that currents are higher than those of the Y-circuit by a factor of 1.73.

The load currents in the table are guideline values for selecting the size of frequency converter. Load current is lower if the load torque is below the values permitted for 30-70 Hz and the frequency inverter used is of the high-grade type. This means that a smaller inverter can sometimes be used, particularly in conjunction with large motors.

Operation with frequency converter, 50 Hz

50 Hz

IE3 Motor torques for frequency-converter range 5 Hz - 100 Hz, line frequency 50 Hz

P kW	Type	Connection	5 Hz M Nm	8.7 Hz M Nm	10 Hz M Nm	20 Hz M Nm	87 Hz M Nm	100 Hz M Nm	5 Hz I A	8.7 Hz I A	10 Hz I A	20 Hz I A	87 Hz I A	100 Hz I A
0.12	DPE05LA4	D	0.49	0.59	0.61	0.73	0.82	0.82	0.64	0.66	0.66	0.68	0.7	0.76
0.12	DPE06LA4	D	0.49	0.59	0.61	0.73	0.82	0.82	0.66	0.67	0.68	0.7	0.72	0.78
0.18	DPE07LA4	D	0.73	0.88	0.92	1.1	1.23	1.23	0.89	0.91	0.92	0.95	0.97	1.07
0.25	DPE08MA4	D	0.99	1.19	1.24	1.49	1.66	1.66	1.07	1.11	1.13	1.19	1.23	1.35
0.37	DPE08LA4	D	1.47	1.76	1.83	2.2	2.4	2.4	1.59	1.64	1.66	1.73	1.79	1.96
0.55	DPE08XA4	D	2.1	2.6	2.7	3.2	3.6	3.6	2.1	2.2	2.2	2.4	2.5	2.7
0.75	DPE08XB4	D	3	3.6	3.8	4.5	5	5	2.8	2.8	2.9	3.1	3.2	3.6
0.75	DPE09LA4	D	3	3.6	3.8	4.5	5	5	2.2	2.5	2.5	2.8	2.9	3.2
1.1	DPE09XA4	D	4.3	5.2	5.4	6.5	7.3	7.3	3.3	3.6	3.6	4	4.2	4.6
1.5	DPE09XB4	D	6	7.1	7.5	9	10	10	4.4	4.8	4.9	5.3	5.7	6.2
2.2	DPE09XB4C	D	8.7	10.4	10.8	13	14.5	14.5	6.5	7	7.1	7.7	8.2	9
2.2	DPE11MA4	D	8.7	10.4	10.8	13	14.5	14.5	6.1	6.6	6.7	7.5	8	8.8
3	DPE11LA4	D	11.8	14.1	14.7	17.7	19.7	19.7	8.3	9	9.1	10.1	10.8	11.8
4	DPE11LB4	D	15.9	19	19.8	23.5	26.5	26.5	9.9	10.9	11.1	12.5	13.6	14.9
5.5	DPE11LB4C	D	21.5	25.5	27	32	36	36	14.3	15.6	15.9	17.8	19.1	21

$P_N$  Rated power

M Permissible load torque (S1-100 %) at the rotor shaft by operation with a frequency inverter

I Load current for operation with frequency inverter

Field weakening for frequencies above 87 Hz, winding for **230 V  $\Delta$  / 50 Hz (Umax = 400 V  $\Delta$  / 87 Hz)**, Temperature Class F.

The load currents in the table are guideline values for selecting the size of frequency inverter. Load current is lower if the load torque is below the values permitted for 30-100 Hz and the frequency inverter used is of the high-grade type. This means that a smaller inverter can sometimes be used, particularly in conjunction with large motors.



## Operation with frequency converter, 60 Hz

60 Hz

## IE1 Motor torques for frequency-converter range 6 Hz - 84 Hz, line frequency 60 Hz

P <sub>N</sub> kW	Type	Connec- tion	6 Hz M Nm	12 Hz M Nm	24 Hz M Nm	36 Hz M Nm	60 Hz M Nm	72 Hz M Nm	84 Hz M Nm	6 Hz I A	12 Hz I A	24 Hz I A	36 Hz I A	60 Hz I A	72 Hz I A	84 Hz I A
0.03	D04LA4	Y	0.115	0.14	0.165	0.18	0.18	0.18	0.15	0.176	0.178	0.18	0.185	0.18	0.205	0.205
0.04	D04LA4	Y	0.145	0.18	0.215	0.235	0.23	0.23	0.18	0.176	0.178	0.18	0.185	0.18	0.205	0.19
0.06	D04LA4	Y	0.22	0.275	0.325	0.355	0.35	0.35	0.3	0.275	0.275	0.28	0.29	0.28	0.32	0.32
0.09	D04LA4	Y	0.33	0.41	0.485	0.53	0.52	0.52	0.445	0.4	0.4	0.4	0.415	0.4	0.455	0.455
0.11	D04LA4	Y	0.38	0.48	0.57	0.63	0.64	0.64	0.57	0.42	0.42	0.42	0.42	0.42	0.465	0.475
0.12	D04LA4	Y	0.445	0.55	0.65	0.71	0.7	0.63	0.465	0.41	0.415	0.42	0.435	0.42	0.435	0.415
0.06	D05LA4	Y	0.22	0.275	0.325	0.355	0.35	0.35	0.3	0.28	0.295	0.315	0.33	0.32	0.365	0.365
0.09	D05LA4	Y	0.33	0.41	0.485	0.53	0.52	0.52	0.445	0.335	0.34	0.35	0.36	0.35	0.395	0.4
0.12	D05LA4	Y	0.445	0.55	0.65	0.71	0.7	0.7	0.53	0.345	0.36	0.375	0.395	0.38	0.43	0.385
0.18	D05LA4	Y	0.67	0.83	0.99	1.08	1.06	1.06	0.87	0.54	0.56	0.58	0.6	0.58	0.66	0.64
0.25	D05LA4	Y	0.92	1.14	1.36	1.48	1.45	1.45	1.15	0.78	0.79	0.8	0.83	0.8	0.91	0.85
0.06	D06LA4	Y	0.22	0.275	0.325	0.355	0.35	0.35	0.3	0.28	0.295	0.315	0.33	0.32	0.365	0.365
0.09	D06LA4	Y	0.33	0.41	0.485	0.53	0.52	0.52	0.445	0.335	0.34	0.35	0.36	0.35	0.395	0.4
0.12	D06LA4	Y	0.445	0.55	0.65	0.71	0.7	0.7	0.53	0.345	0.36	0.375	0.395	0.38	0.43	0.385
0.18	D06LA4	Y	0.67	0.83	0.99	1.08	1.06	1.06	0.87	0.54	0.56	0.58	0.6	0.58	0.66	0.64
0.25	D06LA4	Y	0.92	1.14	1.36	1.48	1.45	1.45	1.15	0.78	0.79	0.8	0.83	0.8	0.91	0.85
0.3	D07LA4	Y	1.12	1.38	1.65	1.8	1.76	1.76	1.5	1.18	1.19	1.2	1.24	1.2	1.36	1.36
0.37	D07LA4	Y	1.37	1.69	2	2.2	2.1	2.1	1.64	1.24	1.25	1.26	1.3	1.26	1.43	1.28
0.37	D08MA4	Y	1.31	1.61	1.92	2.1	2	2	1.75	0.93	0.97	1.01	1.05	1.02	1.16	1.16
0.55	DSE08MA4	Y	1.86	2.3	2.8	3	3.1	3.1	2.8	1.14	1.19	1.25	1.28	1.28	1.42	1.45
0.75	DSE08LA4	Y	2.5	3.1	3.8	4.1	4.2	4.2	3.8	1.51	1.59	1.69	1.75	1.75	1.94	1.98
1.1	DSE08XA4	Y	3.7	4.6	5.5	6.1	6.2	6.2	5.2	2.2	2.3	2.4	2.5	2.5	2.8	2.6
1.1	DSE09SA4	Y	3.6	4.5	5.4	5.9	6	6	5.4	1.96	2.1	2.2	2.3	2.3	2.6	2.6
1.5	DSE09LA4	Y	5	6.1	7.4	8.1	8.2	8.2	7.4	2.6	2.8	3	3.1	3.1	3.5	3.6
2.2	DSE09XA4	Y	7.3	9.1	10.9	12	12.2	12.2	10.9	3.5	3.8	4.1	4.3	4.3	4.8	4.9
3	DSE11SA4	Y	9.8	12.3	14.7	16.2	16.4	16.4	14.7	4.3	4.7	5.2	5.5	5.5	6.1	6.3
4	DSE11MA4	Y	13.1	16.4	19.7	21.5	21.5	21.5	19.7	5.4	6.1	6.8	7.2	7.2	8	8.2
5.5	DSE11LA4	Y	18.1	22.5	27	29.5	30	30	27	7.3	8.1	9.1	9.7	9.7	10.8	11

P<sub>N</sub> Rated power

M Permissible load torque (S1-100 %) at the rotor shaft by operation with a frequency inverter

I Load current for operation with frequency inverter

Field weakening for frequencies above 60 Hz, winding for standard voltage **460 V Y / 60 Hz**, Temperature Class F.

Motors with standard windings can be switched from Y- to Δ- circuit for operation with a converter having a single-phase mains connection. This has no effect on the torques and frequencies as listed in the table above. As regards the choice of converter, however, note that currents are higher than those of the Y-circuit by a factor of 1.73.

The load currents in the table are guideline values for selecting the size of frequency converter. Load current is lower if the load torque is below the values permitted for 36-84 Hz and the frequency inverter used is of the high-grade type. This means that a smaller inverter can sometimes be used, particularly in conjunction with large motors.

Operation with frequency converter, 60 Hz

60 Hz

### IE1 Motor torques for frequency-converter range 6 Hz - 120 Hz. line frequency 60 Hz

P <sub>N</sub> kW	Type	Connec- tion	6 Hz	12 Hz	24 Hz	36 Hz	104 Hz	120 Hz	6 Hz	12 Hz	24 Hz	36 Hz	104 Hz	120 Hz
			M Nm	M Nm	M Nm	M Nm	M Nm	M Nm	M Nm	I A	I A	I A	I A	I A
0.03	D04LA4	D	0.115	0.14	0.165	0.18	0.18	0.18	0.305	0.31	0.315	0.325	0.315	0.345
0.04	D04LA4	D	0.145	0.18	0.215	0.235	0.23	0.23	0.305	0.31	0.315	0.325	0.315	0.345
0.06	D04LA4	D	0.22	0.275	0.325	0.355	0.35	0.35	0.47	0.475	0.485	0.5	0.485	0.54
0.09	D04LA4	D	0.33	0.41	0.485	0.53	0.52	0.52	0.69	0.69	0.7	0.72	0.7	0.77
0.11	D04LA4	D	0.38	0.48	0.57	0.63	0.64	0.64	0.73	0.73	0.73	0.73	0.73	0.8
0.12	D04LA4	D	0.445	0.55	0.65	0.71	0.7	0.69	0.71	0.72	0.73	0.75	0.73	0.79
0.06	D05LA4	D	0.22	0.275	0.325	0.355	0.35	0.35	0.48	0.51	0.55	0.57	0.56	0.61
0.09	D05LA4	D	0.33	0.41	0.485	0.53	0.52	0.52	0.58	0.59	0.61	0.63	0.61	0.67
0.12	D05LA4	D	0.445	0.55	0.65	0.71	0.7	0.7	0.6	0.62	0.65	0.68	0.66	0.73
0.18	D05LA4	D	0.67	0.83	0.99	1.08	1.06	1.06	0.93	0.96	1	1.04	1.01	1.11
0.25	D05LA4	D	0.92	1.14	1.36	1.48	1.45	1.45	1.34	1.36	1.38	1.43	1.39	1.53
0.06	D06LA4	D	0.22	0.275	0.325	0.355	0.35	0.35	0.48	0.51	0.55	0.57	0.56	0.61
0.09	D06LA4	D	0.33	0.41	0.485	0.53	0.52	0.52	0.58	0.59	0.61	0.63	0.61	0.67
0.12	D06LA4	D	0.445	0.55	0.65	0.71	0.7	0.7	0.6	0.62	0.65	0.68	0.66	0.73
0.18	D06LA4	D	0.67	0.83	0.99	1.08	1.06	1.06	0.93	0.96	1	1.04	1.01	1.11
0.25	D06LA4	D	0.92	1.14	1.36	1.48	1.45	1.45	1.34	1.36	1.38	1.43	1.39	1.53
0.3	D07LA4	D	1.12	1.38	1.65	1.8	1.76	1.76	2.1	2.1	2.1	2.2	2.1	2.3
0.37	D07LA4	D	1.37	1.69	2	2.2	2.1	2.1	2.2	2.2	2.2	2.2	2.2	2.4
0.37	D08MA4	D	1.31	1.61	1.92	2.1	2	2	1.6	1.67	1.74	1.82	1.77	1.95
0.55	DSE08MA4	D	1.86	2.3	2.8	3	3.1	3.1	1.97	2.1	2.2	2.2	2.2	2.5
0.75	DSE08LA4	D	2.5	3.1	3.8	4.1	4.2	4.2	2.7	2.8	3	3.1	3.1	3.4
1.1	DSE08XA4	D	3.7	4.6	5.5	6.1	6.2	6.2	3.8	4	4.2	4.2	4.2	4.7
1.1	DSE09SA4	D	3.6	4.5	5.4	5.9	6	6	3.4	3.6	3.8	4	4	4.4
1.5	DSE09LA4	D	5	6.1	7.4	8.1	8.2	8.2	4.5	4.8	5.2	5.4	5.4	6
2.2	DSE09XA4	D	7.3	9.1	10.9	12	12.2	12.2	6	6.5	7.1	7.4	7.5	8.2
3	DSE11SA4	D	9.8	12.3	14.7	16.2	16.4	16.4	7.4	8.2	9	9.5	9.6	10.5
4	DSE11MA4	D	13.1	16.4	19.7	21.5	21.5	21.5	9.4	10.5	11.7	12.4	12.5	13.8
5.5	DSE11LA4	D	18.1	22.5	27	29.5	30	30	12.6	14.1	15.7	16.7	16.9	18.5

P<sub>N</sub> Rated power

M Permissible load torque (S1-100 %) at the rotor shaft by operation with a frequency inverter

I Load current for operation with frequency inverter

Field weakening for frequencies above 87 Hz, winding for standard voltage 265 V Δ / 60 Hz (U<sub>max</sub> = 460 V Δ / 104 Hz), Temperature Class F.

The load currents in the table are guideline values for selecting the size of frequency converter. Load current is lower if the load torque is below the values permitted for 36-120 Hz and the frequency inverter used is of the high-grade type. This means that a smaller inverter can sometimes be used, particularly in conjunction with large motors.

## Operation with frequency converter, 60 Hz

60 Hz

## IE2 Motor torques for frequency-converter range 5 Hz - 80 Hz, line frequency 60 Hz

P kW	Type	Con- nec- tion	5 Hz	10 Hz	20 Hz	30 Hz	60 Hz	70 Hz	80 Hz	5 Hz	10 Hz	20 Hz	30 Hz	60 Hz	70 Hz	80 Hz
			M Nm	M Nm	M Nm	M Nm	M Nm	M Nm	M Nm	M Nm	M Nm	I A	I A	I A	I A	I A
0.12	DHE05LA4	Y	0.4	0.5	0.6	0.66	0.67	0.67	0.6	0.335	0.345	0.355	0.36	0.36	0.4	0.41
0.18	DHE05LA4	Y	0.6	0.75	0.9	0.99	1.01	1.01	0.9	0.485	0.5	0.51	0.52	0.52	0.58	0.59
0.12	DHE06LA4	Y	0.4	0.5	0.6	0.66	0.67	0.67	0.6	0.34	0.35	0.355	0.36	0.36	0.4	0.41
0.18	DHE06LA4	Y	0.6	0.75	0.9	0.99	1.01	1.01	0.9	0.495	0.51	0.52	0.53	0.53	0.59	0.6
0.25	DHE07LA4	Y	0.84	1.05	1.26	1.38	1.4	1.4	1.26	0.65	0.67	0.69	0.7	0.7	0.78	0.8
0.3	DHE07LA4	Y	1.02	1.27	1.53	1.67	1.7	1.7	1.53	0.76	0.78	0.81	0.82	0.82	0.91	0.93
0.37	DHE08MA4	Y	1.2	1.5	1.8	1.97	2	2	1.8	0.9	0.94	0.97	0.99	0.99	1.1	1.12
0.55	DHE08LA4	Y	1.83	2.2	2.7	3	3	3	2.7	1.05	1.11	1.18	1.23	1.23	1.37	1.39
0.75	DHE08XA4	Y	2.4	3.1	3.7	4.1	4.1	4.1	3.7	1.45	1.5	1.56	1.6	1.6	1.78	1.81
0.75	DHE09SA4	Y	2.4	3.1	3.7	4.1	4.1	4.1	3.7	1.34	1.43	1.53	1.6	1.6	1.78	1.81
1.1	DHE09LA4	Y	3.6	4.5	5.4	5.9	6	6	5.4	1.85	1.99	2.2	2.2	2.2	2.5	2.6
1.5	DHE09XA4	Y	4.9	6.1	7.3	8.1	8.2	8.2	7.3	2.4	2.6	2.8	3	3	3.3	3.4
2.2	DHE09XA4C	Y	7.2	9	10.8	11.8	12	12	10.8	3.3	3.6	3.8	4	4	4.5	4.5
2.2	DHE09XB4	Y	7.2	9	10.8	11.9	12.1	12.1	10.8	3.2	3.6	3.9	4.1	4.1	4.5	4.7
2.2	DHE11SA4	Y	7.2	9	10.8	11.8	12	12	10.8	3.1	3.5	3.8	4	4	4.5	4.5
3	DHE11MA4	Y	9.9	12.3	14.8	16.2	16.5	16.5	14.8	4.2	4.7	5.2	5.5	5.5	6.1	6.3
4	DHE11LA4	Y	13	16.2	19.5	21	21.5	21.5	19.5	6.2	6.6	7	7.3	7.3	8.1	8.3
5.5	DHE11LA4C	Y	18	22.5	27	29.5	30	30	27	7.2	8	8.9	9.5	9.5	10.6	10.8
5.5	DHE11LB4	Y	18	22.5	27	29.5	30	30	27	7.5	8.2	9.1	9.6	9.6	10.7	10.9

P<sub>N</sub> Rated power

M Permissible load torque (S1-100 %) at the rotor shaft by operation with a frequency inverter

I Load current for operation with frequency inverter

Field weakening for frequencies above 60 Hz, winding for standard voltage **460 V Y / 60 Hz**, Temperature Class F.

Motors with standard windings can be switched from Y- to Δ- circuit for operation with a converter having a single-phase mains connection. This has no effect on the torques and frequencies as listed in the table above. As regards the choice of converter, however, note that currents are higher than those of the Y-circuit by a factor of 1.73.

The load currents in the table are guideline values for selecting the size of frequency converter. Load current is lower if the load torque is below the values permitted for 36-84 Hz and the frequency inverter used is of the high-grade type. This means that a smaller inverter can sometimes be used, particularly in conjunction with large motors.

Operation with frequency converter, 60 Hz

60 Hz

IE2 Motor torques for frequency-converter range 5 Hz - 120 Hz. line frequency 60 Hz

P kW	Typ	Connection	5 Hz	10 Hz	20 Hz	30 Hz	104 Hz	120 Hz	5 Hz	10 Hz	20 Hz	30 Hz	104 Hz	120 Hz
			M Nm	M Nm	M Nm	M Nm	M Nm	M Nm	M Nm	I A	I A	I A	I A	I A
0.12	DHE05LA4	D	0.4	0.5	0.6	0.66	0.67	0.67	0.58	0.6	0.62	0.63	0.63	0.69
0.18	DHE05LA4	D	0.6	0.75	0.9	0.99	1.01	1.01	0.84	0.86	0.89	0.9	0.91	0.99
0.12	DHE06LA4	D	0.4	0.5	0.6	0.66	0.67	0.67	0.59	0.6	0.62	0.63	0.63	0.69
0.18	DHE06LA4	D	0.6	0.75	0.9	0.99	1.01	1.01	0.86	0.88	0.91	0.92	0.92	1.01
0.25	DHE07LA4	D	0.84	1.05	1.26	1.38	1.4	1.4	1.12	1.15	1.19	1.21	1.22	1.34
0.3	DHE07LA4	D	1.02	1.27	1.53	1.67	1.7	1.7	1.3	1.35	1.39	1.42	1.43	1.57
0.37	DHE08MA4	D	1.2	1.5	1.8	1.97	2	2	1.56	1.62	1.68	1.71	1.72	1.89
0.55	DHE08LA4	D	1.83	2.2	2.7	3	3	3	1.81	1.92	2.1	2.2	2.2	2.4
0.75	DHE08XA4	D	2.4	3.1	3.7	4.1	4.1	4.1	2.6	2.6	2.7	2.8	2.8	3.1
0.75	DHE09SA4	D	2.4	3.1	3.7	4.1	4.1	4.1	2.4	2.5	2.7	2.8	2.8	3.1
1.1	DHE09LA4	D	3.6	4.5	5.4	5.9	6	6	3.2	3.5	3.8	3.9	3.9	4.3
1.5	DHE09XA4	D	4.9	6.1	7.3	8.1	8.2	8.2	4.2	4.5	4.9	5.1	5.2	5.7
2.2	DHE09XA4C	D	7.2	9	10.8	11.8	12	12	5.7	6.1	6.6	6.9	7	7.7
2.2	DHE09XB4	D	7.2	9	10.8	11.9	12.1	12.1	5.7	6.2	6.7	7.1	7.2	7.9
2.2	DHE11SA4	D	7.2	9	10.8	11.8	12	12	5.4	5.9	6.5	6.9	7	7.7
3	DHE11MA4	D	9.9	12.3	14.8	16.2	16.5	16.5	7.4	8.1	9	9.5	9.6	10.5
4	DHE11LA4	D	13	16.2	19.5	21	21.5	21.5	10.7	11.4	12.2	12.6	12.7	13.9
5.5	DHE11LA4C	D	18	22.5	27	29.5	30	30	12.4	13.8	15.4	16.4	16.5	18.1
5.5	DHE11LB4	D	18	22.5	27	29.5	30	30	12.9	14.2	15.6	16.5	16.7	18.3

- $P_N$  Rated power
- M Permissible load torque (S1-100 %) at the rotor shaft by operation with a frequency inverter
- I Load current for operation with frequency inverter

Field weakening for frequencies above 87 Hz, winding for standard voltage 265 V  $\Delta$  / 60 Hz ( $U_{max} = 460$  V  $\Delta$  / 104 Hz), Temperature Class F.

The load currents in the table are guideline values for selecting the size of frequency converter. Load current is lower if the load torque is below the values permitted for 36-120 Hz and the frequency inverter used is of the high-grade type. This means that a smaller inverter can sometimes be used, particularly in conjunction with large motors.

## Operation with frequency converter, 60 Hz

60 Hz

## IE3 Motor torques for frequency-converter range 5 Hz - 80 Hz, line frequency 60 Hz

P kW	Type	Connec- tion	5 Hz	10 Hz	20 Hz	30 Hz	60 Hz	70 Hz	80 Hz	5 Hz	10 Hz	20 Hz	30 Hz	60 Hz	70 Hz	80 Hz
			M Nm	M Nm	M Nm	M Nm	M Nm	M Nm	M Nm	M Nm	I A	I A	I A	I A	I A	I A
0.12	DPE05LA4	Y	0.4	0.5	0.6	0.66	0.67	0.67	0.6	0.345	0.355	0.365	0.37	0.37	0.41	0.42
0.12	DPE06LA4	Y	0.4	0.5	0.6	0.66	0.67	0.67	0.6	0.35	0.36	0.365	0.37	0.37	0.41	0.42
0.18	DPE07LA4	Y	0.6	0.75	0.9	0.98	1	1	0.9	0.48	0.495	0.51	0.52	0.52	0.58	0.59
0.25	DPE08MA4	Y	0.82	1.02	1.23	1.35	1.37	1.37	1.23	0.57	0.6	0.63	0.65	0.65	0.72	0.74
0.37	DPE08LA4	Y	1.2	1.5	1.8	1.97	2	2	1.8	0.85	0.88	0.92	0.94	0.94	1.05	1.07
0.55	DPE08XA4	Y	1.8	2.2	2.7	2.9	3	3	2.7	1.08	1.14	1.21	1.25	1.25	1.39	1.42
0.75	DPE08XB4	Y	2.4	3.1	3.7	4.1	4.1	4.1	3.7	1.43	1.51	1.61	1.67	1.67	1.85	1.89
0.75	DPE09LA4	Y	2.4	3	3.6	4	4.1	4.1	3.6	1.16	1.26	1.37	1.44	1.45	1.61	1.64
1.1	DPE09XB4	Y	3.6	4.5	5.4	5.9	6	6	5.4	1.8	1.94	2.1	2.2	2.2	2.5	2.5
1.5	DPE09XB4	Y	4.9	6.1	7.3	8.1	8.2	8.2	7.3	2.4	2.6	2.8	2.9	2.9	3.2	3.3
2.2	DPE11LB4	Y	7.1	8.9	10.7	11.7	11.9	11.9	10.7	2.8	3.1	3.5	3.7	3.7	4.1	4.2
3	DPE11LB4	Y	9.7	12.2	14.6	16.1	16.3	16.3	14.6	3.9	4.4	4.9	5.2	5.2	5.8	5.9
4	DPE11LB4	Y	13	16.2	19.5	21	21.5	21.5	19.5	5.2	5.8	6.5	6.9	6.9	7.7	7.8

$P_N$  Rated power

M Permissible load torque (S1-100 %) at the rotor shaft by operation with a frequency inverter

I Load current for operation with frequency inverter

Field weakening for frequencies above 60 Hz, winding for standard voltage **460 V Y / 60 Hz**, Temperature Class F.

Motors with standard windings can be switched from Y- to  $\Delta$ - circuit for operation with a converter having a single-phase mains connection. This has no effect on the torques and frequencies as listed in the table above. As regards the choice of converter, however, note that currents are higher than those of the Y-circuit by a factor of 1.73.

The load currents in the table are guideline values for selecting the size of frequency converter. Load current is lower if the load torque is below the values permitted for 36-84 Hz and the frequency inverter used is of the high-grade type. This means that a smaller inverter can sometimes be used, particularly in conjunction with large motors.

Operation with frequency converter, 60 Hz

60 Hz

IE3 Motor torques for frequency-converter range 5 Hz - 120 Hz, line frequency 60 Hz

P kW	Type	Connection	5 Hz M Nm	10 Hz M Nm	20 Hz M Nm	30 Hz M Nm	104 Hz M Nm	120 Hz M Nm	5 Hz I A	10 Hz I A	20 Hz I A	30 Hz I A	104 Hz I A	120 Hz I A
0.12	DPE05LA4	D	0.4	0.5	0.6	0.66	0.67	0.67	0.6	0.62	0.63	0.64	0.65	0.71
0.12	DPE06LA4	D	0.4	0.5	0.6	0.66	0.67	0.67	0.61	0.62	0.64	0.64	0.65	0.71
0.18	DPE07LA4	D	0.6	0.75	0.9	0.98	1	1	0.83	0.86	0.89	0.9	0.91	0.99
0.25	DPE08MA4	D	0.82	1.02	1.23	1.35	1.37	1.37	0.99	1.04	1.09	1.13	1.13	1.24
0.37	DPE08LA4	D	1.2	1.5	1.8	1.97	2	2	1.47	1.52	1.59	1.63	1.63	1.79
0.55	DPE08XA4	D	1.8	2.2	2.7	2.9	3	3	1.87	1.98	2.1	2.2	2.2	2.4
0.75	DPE08XB4	D	2.4	3.1	3.7	4.1	4.1	4.1	2.5	2.7	2.8	2.9	2.9	3.2
0.75	DPE09LA4	D	2.4	3	3.6	4	4.1	4.1	2.1	2.2	2.4	2.5	2.6	2.8
1.1	DPE09XB4	D	3.6	4.5	5.4	5.9	6	6	3.2	3.4	3.7	3.8	3.8	4.2
1.5	DPE09XB4	D	4.9	6.1	7.3	8.1	8.2	8.2	4	4.4	4.8	5	5.1	5.6
2.2	DPE11LB4	D	7.1	8.9	10.7	11.7	11.9	11.9	4.7	5.3	6	6.4	6.5	7.1
3	DPE11LB4	D	9.7	12.2	14.6	16.1	16.3	16.3	6.7	7.5	8.4	9	9.1	9.9
4	DPE11LB4	D	13	16.2	19.5	21	21.5	21.5	8.9	10	11.2	11.9	12	13.2

$P_N$  Rated power

$M$  Permissible load torque (S1-100 %) at the rotor shaft by operation with a frequency inverter

$I$  Load current for operation with frequency inverter

Field weakening for frequencies above 87 Hz, winding for standard voltage 265 V  $\Delta$  / 60 Hz ( $U_{max} = 460$  V  $\Delta$  / 104 Hz), Temperature Class F.

The load currents in the table are guideline values for selecting the size of frequency converter. Load current is lower if the load torque is below the values permitted for 36-120 Hz and the frequency inverter used is of the high-grade type. This means that a smaller inverter can sometimes be used, particularly in conjunction with large motors.

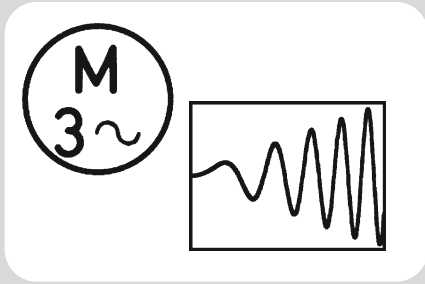

# 12

### Motors - BM

<b>Motor configuration</b> .....	<b>205</b>
Torque-speed characteristic .....	205
<b>Motor configuration</b> .....	<b>206</b>
<b>Technical data</b> .....	<b>209</b>
<b>Standard Motors</b> .....	<b>209</b>
Motors with rated speed 1500 1/min .....	209
Rated speed 1500 1/min .....	210
Motor-Drehmomente bei Stellbereich 150 1/min - 1800 1/min, Betriebsart S1 .....	211
Motors with rated speed 2250 1/min .....	215
Rated speed 2250 1/min .....	216
Motor-Drehmomente bei Stellbereich 150 1/min - 2600 1/min, Betriebsart S1 .....	217
Motors with rated speed 3000 1/min .....	219
Rated speed 3000 1/min .....	220
Motor torques in the adjusting range 150 1/min - 3600 1/min, duty type S1 .....	222

# Energy Efficient Geared Motors

## Electric overhead conveyors series BM

---



### Torque-speed characteristic

The torque versus speed curve shows the operating characteristics of the PMSM. The reference points shown schematically on the torque versus speed curve are significant criteria for motor selection.

### Torque vs. Speed Curve

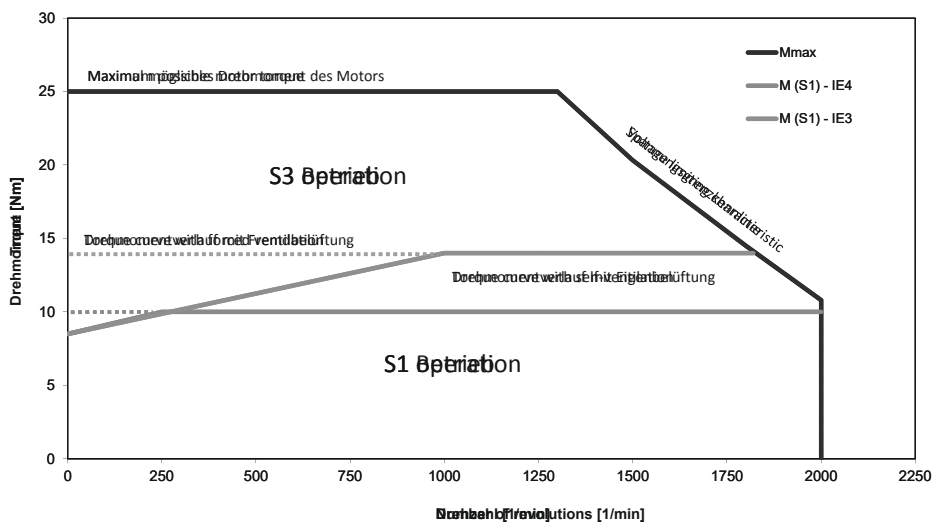

The motor is determined by the effective motor torque and the average motor speed. Both values  $M_{eff}$  and  $n_{eff}$  must be below the S1 limit characteristic curve of the motor to be selected.

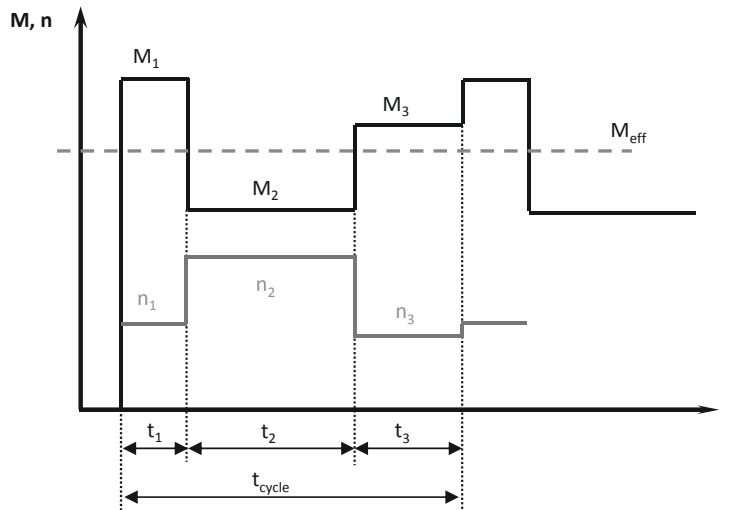

### Effective torque

$$M_{\text{eff}} = \sqrt{\frac{M_1^2 \cdot t_1 + M_2^2 \cdot t_2 + M_3^2 \cdot t_3 + \dots + M_n^2 \cdot t_n}{t_1 + t_2 + t_3 + \dots + t_n}}$$

### Effective rpm

$$n_{\text{eff}} = \frac{n_1 \cdot t_1 + n_2 \cdot t_2 + n_3 \cdot t_3 + \dots + n_n \cdot t_n}{t_1 + t_2 + t_3 + \dots + t_n}$$

### Acceleration

#### Dynamic power

The dynamic power is the power that accelerates the entire system (load, transmission components, gears and motor)

$$P_{\text{dyn}} = \frac{m \times a \times v}{\eta}$$

$P_{\text{dyn}}$	Dynamic power [W]
$m$	Mass [kg]
$a$	Acceleration [m/s <sup>2</sup> ]
$v$	Speed [m/s]
$\eta$	Level of efficiency

Dynamic load torque

$$M_{\text{dyn}_1} = m \cdot a \cdot \frac{1}{\eta} \cdot \frac{D}{2} \cdot \frac{1}{i}$$

$D$	Impeller diameter
$i$	Gear reduction ratio

### Constant speed

#### Static performance

The static power takes into account all forces that occur in the unaccelerated state. These include: rolling friction, frictional forces, lifting capacity on slopes and wind force.

$$P_s = \frac{F_F \times v}{\eta}$$

$P_s$	Static power [W]
$F_F$	Driving resistance [N]

#### Static load torque (simplified)

$$M_{\text{statt}} = m \cdot g \cdot \frac{1}{\eta} \cdot \frac{D}{2} \cdot \frac{1}{i}$$

$g$	Acceleration due to gravity
-----	-----------------------------

### Deceleration

#### Deceleration torque

$$M_{\text{dyn2}} = m \cdot (-a) \cdot \eta_L \cdot \frac{D}{2} \cdot \frac{1}{i}$$

$$M_{\text{VER}} = M_{\text{stat}} + M_{\text{dyn2}}$$

$M_{\text{Verz}}$  Deceleration torque

#### Load torques in the driving cycle

Acceleration phase

$$M_{\text{Motor}} = M_{\text{stat}} + M_{\text{dyn1}}$$

Constant speed

$$M_{\text{Motor}} = M_{\text{stat}}$$

Braking phase

$$M_{\text{Motor}} = M_{\text{stat}} + M_{\text{dyn2}}$$

#### Motor selection

Example:

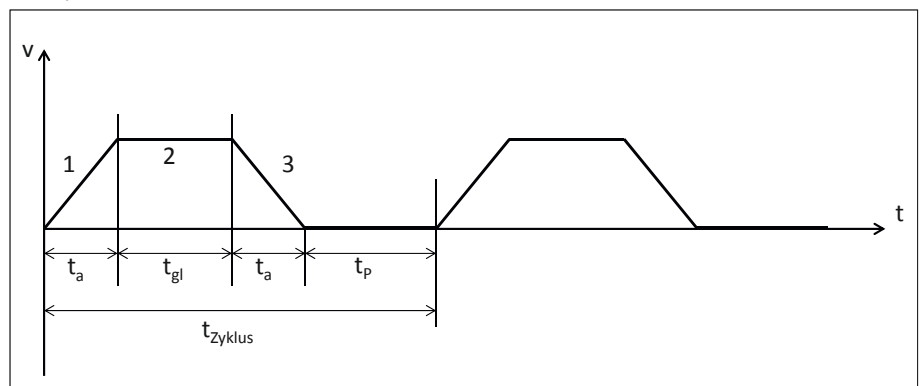

Required dynamic torque on the motor (acceleration):	M1	= 20Nm
Required static torque on the motor:	M2	= 8,0Nm
Deceleration torque:	M3	= 10Nm
Acceleration time/deceleration time	$t_a$	= 0,5s
Duration constant travel	$t_{gl}$	= 5s
Cycle time	$t_{Zykl}$	= 10s
Motor speed for constant travel	n	= 1450 1/min

Effective motor torque and moderate motor speed

$$M_{\text{eff}} = \sqrt{\frac{M_1^2 \cdot t_a + M_2^2 \cdot t_{gl} + M_3^2 \cdot t_a}{t_{Zykl}}} = 7,55 \text{ Nm}$$

$$n_{\text{eff}} = \frac{n \cdot t_a + n \cdot t_{gl} + n \cdot t_a}{t_{Zykl}} = \frac{n \cdot (2 \cdot t_a + t_{gl})}{t_{Zykl}} = 870 \text{ min}^{-1}$$

# Motors - BM

## Motor configuration

The following motor is selected:

Type: SSE08LA4  
Rated power  $P_n = 1,55 \text{ kW}$   
Rated torque  $M_n = 10 \text{ Nm}$   
Rated speed  $n_n = 1500 \text{ min}^{-1}$

With proper utilisation of the gears by doubling the reduction and increasing the revs of the motor to  $3000 \text{ min}^{-1}$ , the torque requirement for the motor can be halved, and this makes it possible to decrease the size of the motor.

Instead of the S08LA4, the following motor could be selected in this case:

Type: S5E08MA4  
Rated power  $P_n = 1,55 \text{ kW}$   
Rated torque  $M_n = 5 \text{ Nm}$   
Rated speed  $n_n = 3000 \text{ min}^{-1}$

This increases the efficiency of the motor on the one hand, while also reducing the package length. The result is a cheaper drive with increased energy savings.

The diagram below shows the potential energy savings of using the different IE efficiency motors.

With the utilisation of the gears and the **use** of the **S08MA4 IE4** motor, **compared** with the **IE3 S08LA4** the **power loss can be reduced by 36.24%** and **by 45.58%** compared with the **IE2 DHE09XA4**.

With 8 hours of operation, 5 days a week and 50 weeks of the year, this results in an **energy saving of 187.37 kW/h** compared with the **IE3 S08LA4** and **276.14 kW/h** compared with the **IE2 DHE09XA4**.

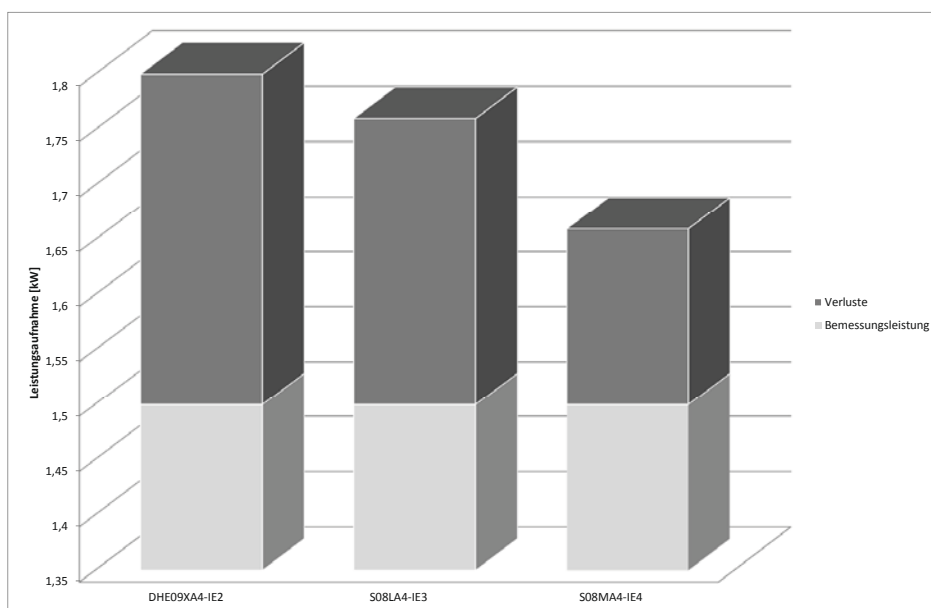

## Standard Motors

## Motors with rated speed 1500 1/min

M <sub>n</sub> Nm	IE Class	Type	P <sub>n</sub> kW	I <sub>n</sub> A	2p	n <sub>n</sub> 1/min	f Hz	η %	Conne- tion	R <sub>20</sub> Ω	R <sub>s20</sub> Ω	L <sub>d</sub> mH	L <sub>q</sub> mH	ke V/1000 1/min	kt Nm/A	M <sub>max</sub> (60s) Nm	I <sub>max</sub> (60s) A	J kgm <sup>2</sup>
0.76	4	S4E04SA4-1	0.12	0.41	4	1500	50	IE4-67.4	Y	154	77.2	268	412	120	1.85	1.6	0.86	0.00014
0.76	3	SPEU04SA4-1	0.12	0.42	4	1500	50	IE3-66	Y	154	77.2	268	412	120	1.8	1.2	0.67	0.00014
1	2	SHE04SA4-1	0.167	0.54	4	1500	50	IE2-61.4	Y	154	77.2	268	412	120	1.85	1.6	0.86	0.00014
1.15	5	S5EU06MA4	0.18	0.49	4	1500	50	IE5-80.8	Y	79	39.5	171	271	152	2.35	2.6	1.1	0.0002
1.3	5	S5E06MA4	0.2	0.55	4	1500	50	IE5-79.6	Y	79	39.5	171	271	152	2.4	3.8	1.6	0.0002
1.3	5	S5EU06MA4	0.2	0.55	4	1500	50	IE5-79.1	Y	79	39.5	171	271	152	2.35	2.6	1.1	0.0002
1.6	4	S4E06MA4	0.25	0.67	4	1500	50	IE4-76.6	Y	79	39.5	171	271	152	2.4	3.8	1.6	0.0002
1.6	4	S4EU06MA4	0.25	0.68	4	1500	50	IE4-75.5	Y	79	39.5	171	271	152	2.35	2.6	1.1	0.0002
1.6	5	S5EU06LA4	0.25	0.7	4	1500	50	IE5-85.5	Y	37.2	18.6	99.5	133	148	2.3	3.8	1.7	0.000295
2.4	1	SSE06MA4	0.37	1	4	1500	50	IE1-66.1	Y	79	39.5	171	271	152	2.4	3.8	1.6	0.0002
2.4	4	S4EU06LA4	0.37	1.05	4	1500	50	IE4-80	Y	37.2	18.6	99.5	133	148	2.3	3.8	1.7	0.000295
2.6	4	S4E06LA4	0.4	1.12	4	1500	50	IE4-79.8	Y	37.2	18.6	99.5	133	148	2.3	5.6	2.4	0.000295
3.5	1	SSE06LA4	0.55	1.5	4	1500	50	IE1-74.1	Y	37.2	18.6	99.5	133	148	2.3	5.6	2.4	0.000295
3.5	5	S5EU08MA4	0.55	1.28	4	1500	50	IE5-87.2	Y	18.7	9.35	97	170	180	2.7	10	3.7	0.00115
5	4	S4E08MA4	0.78	1.8	4	1500	50	IE4-85.7	Y	18.7	9.35	97	170	180	2.8	10	3.7	0.00115
5	5	S5EU08LA4	0.78	1.9	4	1500	50	IE5-86.9	Y	11	5.5	70	117	171	2.6	15	5.6	0.0015
7	3	SPE08LA4	1.1	2.6	4	1500	50	IE3-85.4	Y	11	5.5	70	117	171	2.75	15	5.6	0.0015
7	5	S5EU09SA4	1.1	2.2	4	1500	50	IE5-90.8	Y	9.9	4.95	64.1	110	208	3.2	20	6.4	0.00245
10	1	SSE08LA4	1.55	3.6	4	1500	50	IE1-80.5	Y	11	5.5	70	117	171	2.8	15	5.6	0.0015
10	4	S4E09SA4	1.55	3	4	1500	50	IE4-88.2	Y	9.9	4.95	64.1	110	208	3.3	20	6.4	0.00245
10	5	S5EU09XA4	1.55	3.1	4	1500	50	IE5-89.9	Y	5.25	2.63	41.2	70.1	209	3.2	30	10	0.0038
14	2	SHE09SA4	2.2	4.3	4	1500	50	IE2-83.9	Y	9.9	4.95	64.1	110	208	3.3	20	6.4	0.00245
14	5	S5E09XA4	2.2	4.2	4	1500	50	IE5-90.3	Y	5.25	2.63	41.2	70.1	209	3.35	31	10	0.0038
14	5	S5EU11SA6	2.2	4.4	6	1500	75	IE5-91.3	Y	3.52	1.76	20	30	210	3.1	40	13	0.012
20	3	SPE09XA4	3.1	5.9	4	1500	50	IE3-88	Y	5.25	2.63	41.2	70.1	209	3.35	31	10	0.0038
19	4	S4E11SA6	3	5.9	6	1500	75	IE4-90.1	Y	3.52	1.76	20	30	210	3.2	35	11	0.012
20	5	S5EU11MA6	3.1	6.4	6	1500	75	IE5-93.3	Y	1.78	0.892	12	18.4	206	3.1	55	17	0.0175
25.5	3	SPE11SA6	4	8	6	1500	75	IE3-87.7	Y	3.52	1.76	20	30	210	3.2	35	11	0.012
25.5	5	S5EU11LA6	4	8.1	6	1500	75	IE5-93.2	Y	1.21	0.605	9.3	13.9	210	3.1	75	23	0.0215
26.5	5	S5E11MA6	4.2	8.3	6	1500	75	IE5-92.5	Y	1.78	0.892	12	18.4	206	3.15	55	17	0.0175
35	5	S5E11LA6	5.5	10.8	6	1500	75	IE5-93.2	Y	1.21	0.605	9.3	13.9	210	3.25	75	23	0.0215
35	4	S4E11MA6	5.5	11	6	1500	75	IE4-90.8	Y	1.78	0.892	12	18.4	206	3.15	55	17	0.0175
48	3	SPE11LA6	7.5	14.7	6	1500	75	IE3-91.4	Y	1.21	0.605	9.3	13.9	210	3.25	75	23	0.0215

M <sub>n</sub>	Rated torque
P <sub>n</sub>	Rated power
I <sub>n</sub>	Rated current
2p	No. of Motor Poles
n <sub>n</sub>	Rated speed
f	Nominal Frequency
η	Motor efficiency
R <sub>20</sub>	Phase Resistance U-V
R <sub>s20</sub>	Winding Resistance
L <sub>d</sub>	Inductance D-Axis
L <sub>q</sub>	Inductance Q-Axis
ke	Voltage constant
kt	Torque constant
M <sub>max</sub> (60s)	Peak Torque
I <sub>max</sub> (60s)	Peak Current
J	Moment of inertia

All motors: converter supply voltage 380 to 500 V

Rated speed 1500 1/min

Rated speed 1500 1/min	η (100%-Load)	η (75%-Load)	η (50%-Load)	IE Class	Manufacturer data	Type	Number of poles	M <sub>n</sub> Nm	P kW	Frequency Hz	Voltage V	n <sub>n</sub> 1/min	Type of motor	Operating conditions	Power losses in % at operating points (Speed/Torque)						
															25/25	25/100	50/25	50/50	50/100	90/50	90/100
	67.4	n.A	n.A	IE4	1) S4E04SA4-1	4	0.76	0.12	50	380	1500	2) 3)	3)	4.1	39.2	5.0	12.2	41.1	14.2	43.9	
	66.0	n.A	n.A	IE3	1) SPEU04SA4-1	4	0.76	0.12	50	380	1500	2) 3)	3)	4.1	42.8	5.2	13.0	44.8	15.2	46.6	
	61.4	n.A	n.A	IE2	1) SHE04SA4-1	4	1	0.157	50	380	1500	2) 3)	3)	4.5	54.3	5.4	15.6	55.2	17.3	56.7	
	80.8	n.A	n.A	IE5	1) S5EU06MA4	4	1.15	0.18	50	380	1500	2) 3)	3)	2.3	18.9	3.3	6.7	19.8	8.5	21.5	
	79.6	n.A	n.A	IE5	1) S5E06MA4	4	1.3	0.2	50	380	1500	2) 3)	3)	2.5	20.6	3.5	7.2	21.6	9.1	23.5	
	79.1	n.A	n.A	IE5	1) S5EU06MA4	4	1.3	0.2	50	380	1500	2) 3)	3)	2.8	21.8	3.6	7.1	22.7	8.6	24.3	
	76.6	n.A	n.A	IE4	1) S4E06MA4	4	1.6	0.25	50	380	1500	2) 3)	3)	2.2	24.8	3.0	7.5	25.6	9.6	27.7	
	75.5	n.A	n.A	IE4	1) S4EU06MA4	4	1.6	0.25	50	380	1500	2) 3)	3)	2.4	27.4	3.0	8.0	28.2	9.3	29.4	
	85.5	n.A	n.A	IE5	1) S5EU06LA4	4	1.6	0.25	50	380	1500	2) 3)	3)	1.9	12.8	2.8	5.1	13.6	6.6	15.3	
	66.1	n.A	n.A	IE1	1) SSE06MA4	4	2.4	0.37	50	380	1500	2) 3)	3)	3.1	45.5	3.7	11.6	46.2	13.3	47.1	
	80.0	n.A	n.A	IE4	1) S4EU06LA4	4	2.4	0.37	50	380	1500	2) 3)	3)	2.0	21.4	2.5	6.4	21.9	7.4	22.9	
	79.8	n.A	n.A	IE4	1) S4E06LA4	4	2.6	0.4	50	380	1500	2) 3)	3)	2.2	20.5	3.0	6.7	21.5	8.5	23.2	
	74.1	n.A	n.A	IE1	1) SSE06LA4	4	3.5	0.55	50	380	1500	2) 3)	3)	1.5	10.6	2.5	4.4	11.6	5.9	13.2	
	87.2	n.A	n.A	IE5	1) S5EU08MA4	4	3.5	0.55	50	380	1500	2) 3)	3)	2.3	29.7	2.9	8.2	30.2	9.4	31.4	
	85.7	n.A	n.A	IE4	1) S4E08MA4	4	5	0.78	50	380	1500	2) 3)	3)	1.4	13.4	1.9	4.4	14.0	5.5	15.2	
	86.9	n.A	n.A	IE5	1) S5EU08LA4	4	5	0.78	50	380	1500	2) 3)	3)	1.7	10.4	2.8	4.7	11.7	6.6	13.7	
	85.4	n.A	n.A	IE3	1) SPE08LA4	4	7	1.1	50	380	1500	2) 3)	3)	1.4	12.7	2.2	4.4	13.7	6.3	15.4	
	90.8	n.A	n.A	IE5	1) S5EU09SA4	4	7	1.1	50	380	1500	2) 3)	3)	0.9	7.7	1.2	2.7	8.3	3.5	9.1	
	80.5	n.A	n.A	IE1	1) SSE08LA4	4	10	1.55	50	380	1500	2) 3)	3)	1.6	21.2	2.3	6.3	21.8	7.5	22.2	
	88.2	n.A	n.A	IE4	1) S4E09SA4	4	10	1.55	50	380	1500	2) 3)	3)	1.2	10.4	1.7	3.7	11.1	4.9	12.2	
	89.9	n.A	n.A	IE5	1) S5EU09XA4	4	10	1.55	50	380	1500	2) 3)	3)	1.6	7.1	2.7	3.9	8.3	5.9	10.3	
	83.9	n.A	n.A	IE2	1) SHE09SA4	4	14	2.2	50	380	1500	2) 3)	3)	1.3	15.9	1.7	4.7	16.4	5.6	17.3	
	90.3	n.A	n.A	IE5	1) S5E09XA4	4	14	2.2	50	380	1500	2) 3)	3)	1.1	7.6	1.8	3.2	8.4	4.4	9.6	
	91.3	n.A	n.A	IE5	1) S5EU11SA6	6	14	2.2	50	380	1500	2) 3)	3)	1.0	6.3	1.7	2.9	7.1	4.4	8.6	
	88.0	n.A	n.A	IE3	1) SPE09XA4	4	20	3.1	50	380	1500	2) 3)	3)	1.0	11.4	1.4	3.5	11.7	4.2	12.5	
	90.1	n.A	n.A	IE4	1) S4E11SA6	6	19	3	75	380	1500	2) 3)	3)	1.0	7.4	1.7	3.1	8.3	4.7	9.9	
	93.3	n.A	n.A	IE5	1) S5EU11MA6	6	20	3.1	75	380	1500	2) 3)	3)	0.8	5.0	1.4	2.2	5.6	3.3	6.6	
	87.7	n.A	n.A	IE3	1) SPE11SA6	6	25.5	4	75	380	1500	2) 3)	3)	1.0	10.9	1.5	3.4	11.5	4.6	12.7	
	93.2	n.A	n.A	IE5	1) S5EU11LA6	6	25.5	4	75	380	1500	2) 3)	3)	0.8	4.5	1.4	2.2	5.3	3.4	6.5	
	92.5	n.A	n.A	IE5	1) S5E11MA6	6	26.5	4.2	75	380	1500	2) 3)	3)	0.7	5.5	1.2	2.3	6.2	3.4	7.2	
	93.2	n.A	n.A	IE5	1) S5E11LA6	6	35	5.5	75	380	1500	2) 3)	3)	0.8	5.0	1.3	2.3	5.6	3.4	6.6	
	90.8	n.A	n.A	IE4	1) S4E11MA6	6	35	5.5	75	380	1500	2) 3)	3)	0.8	7.7	1.2	2.6	8.2	3.5	9.1	
	91.4	n.A	n.A	IE3	1) SPE11LA6	6	48	7.5	75	380	1500	2) 3)	3)	0.7	7.2	1.1	2.4	7.7	3.3	8.5	

\*Dimensioned according to IEC TS 60034-30-2

1) Manufacturer:	Bauer Gear Motor GmbH	2) Type of motor:	Three-phase permanent magnet excited synchronous motor	3) Installation altitude above sea level (m):	1000
Commercial register number:	HRB 736269	Ambient temperature:	-20 °C to +40 °C		
Address:	Eberhard-Bauer-Str. 37, 73734 Esslingen / Germany				

The figures given in the table below are for Bauer motors operating in conjunction with the frequency inverter. The torques referred to in tables can be entered for the respective frequencies in continuous operation (S1 = duty factor 100 %).

#### Motor-Drehmomente bei Stellbereich 150 1/min - 1800 1/min, Betriebsart S1

M <sub>n</sub> Nm	P <sub>n</sub> kW	Typ	Drehzahl 1/min	Drehmoment Nm	Leistung kW	Strom A	Frequenz Hz	Schaltung
0.76	0.12	S4E04SA4-1	150	0.76	0.012	0.41	5	Y
			500	0.76	0.04	0.41	16.67	Y
			1000	0.76	0.08	0.41	33.33	Y
			1500	0.76	0.12	0.41	50	Y
			1800	0.76	0.143	0.41	60	Y
0.76	0.12	SPEU04SA4-1	150	0.76	0.012	0.42	5	Y
			500	0.76	0.04	0.42	16.67	Y
			1000	0.76	0.08	0.42	33.33	Y
			1500	0.76	0.12	0.42	50	Y
			1800	0.76	0.143	0.42	60	Y
1	0.157	SHE04SA4-1	150	0.76	0.012	0.41	5	Y
			500	0.85	0.045	0.46	16.67	Y
			1000	1	0.105	0.54	33.33	Y
			1500	1	0.157	0.54	50	Y
			1800	1	0.188	0.54	60	Y
1.15	0.18	S5EU06MA4	150	1.15	0.018	0.49	5	Y
			500	1.15	0.06	0.49	16.67	Y
			1000	1.15	0.12	0.49	33.33	Y
			1500	1.15	0.18	0.49	50	Y
			1800	1.15	0.217	0.49	60	Y
1.3	0.2	S5E06MA4	150	1.3	0.02	0.55	5	Y
			500	1.3	0.068	0.55	16.67	Y
			1000	1.3	0.136	0.55	33.33	Y
			1500	1.3	0.2	0.55	50	Y
			1800	1.3	0.245	0.55	60	Y
1.3	0.2	S5EU06MA4	150	1.3	0.02	0.55	5	Y
			500	1.3	0.068	0.55	16.67	Y
			1000	1.3	0.136	0.55	33.33	Y
			1500	1.3	0.2	0.55	50	Y
			1800	1.3	0.245	0.55	60	Y
1.6	0.25	S4E06MA4	150	1.6	0.025	0.67	5	Y
			500	1.6	0.092	0.67	16.67	Y
			1000	1.6	0.168	0.67	33.33	Y
			1500	1.6	0.25	0.67	50	Y
			1800	1.6	0.3	0.67	60	Y
1.6	0.25	S4EU06MA4	150	1.6	0.025	0.68	5	Y
			500	1.6	0.084	0.68	16.67	Y
			1000	1.6	0.168	0.68	33.33	Y
			1500	1.6	0.25	0.68	50	Y
			1800	1.6	0.3	0.7	60	Y
1.6	0.25	S5EU06LA4	150	1.6	0.025	0.7	5	Y
			500	1.6	0.084	0.7	16.67	Y
			1000	1.6	0.168	0.7	33.33	Y
			1500	1.6	0.25	0.7	50	Y
			1800	1.6	0.3	0.7	60	Y
2.4	0.37	SSE06MA4	150	1.8	0.028	0.75	5	Y
			500	2	0.105	0.84	16.67	Y
			1000	2.2	0.23	0.93	33.33	Y
			1500	2.4	0.37	1	50	Y
			1800	2.4	0.45	1	60	Y

# Motors - BM

## Technical data

M <sub>n</sub> Nm	P <sub>n</sub> kW	Type	Speed 1/min	Torque Nm	Power kW	Current A	Frequency Hz	Connection
2.4	0.37	S4EU06LA4	150	2.4	0.038	1.05	5	Y
			500	2.4	0.126	1.05	16.67	Y
			1000	2.4	0.25	1.05	33.33	Y
			1500	2.4	0.37	1.05	50	Y
			1800	2.4	0.45	1.05	60	Y
2.6	0.37	S4E06LA4	150	2.5	0.04	1.07	5	Y
			500	2.6	0.136	1.12	16.67	Y
			1000	2.6	0.27	1.12	33.33	Y
			1500	2.6	0.4	1.12	50	Y
			1800	2.6	0.5	1.12	60	Y
3.5	0.55	SSE06LA4	150	2.5	0.04	1.07	5	Y
			500	2.9	0.15	1.25	16.67	Y
			1000	3.5	0.37	1.5	33.33	Y
			1500	3.5	0.55	1.5	50	Y
			1800	3.5	0.66	1.5	60	Y
3.5	0.55	S5EU08MA4	150	3.5	0.06	1.28	5	Y
			500	-	-	-	16.67	Y
			1000	-	-	-	33.33	Y
			1500	3.5	0.55	1.28	50	Y
			1800	3.5	0.66	1.28	60	Y
5	0.78	S4E08MA4	150	5	0.08	1.8	5	Y
			500	5	0.26	1.8	16.67	Y
			1000	5	0.52	1.8	33.33	Y
			1500	5	0.78	1.8	50	Y
			1800	5	0.9	1.8	60	Y
5	0.78	S5EU08LA4	150	5	0.08	1.9	5	Y
			500	-	-	-	16.67	Y
			1000	-	-	-	33.33	Y
			1500	5	0.78	1.9	50	Y
			1800	5	0.9	1.9	60	Y
7	1.1	SPE08LA4	150	6.5	0.1	2.4	5	Y
			500	7	0.37	2.6	16.67	Y
			1000	7	0.73	2.6	33.33	Y
			1500	7	1.1	2.6	50	Y
			1800	7	1.3	2.6	60	Y
7	1.1	S5EU09SA4	150	7	0.11	2.2	5	Y
			500	-	-	-	16.67	Y
			1000	-	-	-	33.33	Y
			1500	7	1.1	2.2	50	Y
			1800	7	1.3	2.2	60	Y
10	1.55	SSE08LA4	150	6.5	0.1	2.4	5	Y
			500	8	0.42	2.9	16.67	Y
			1000	10	1.05	3.6	33.33	Y
			1500	10	1.55	3.6	50	Y
			1800	10	1.9	3.6	60	Y
10	1.55	S4E09SA4	150	8.5	0.13	2.6	5	Y
			500	10	0.52	3	16.67	Y
			1000	10	1.05	3	33.33	Y
			1500	10	1.55	3	50	Y
			1800	10	1.9	3	60	Y
10	1.55	S5EU09XA4	150	10	0.16	3.1	5	Y
			500	-	-	-	16.67	Y
			1000	-	-	-	33.33	Y
			1500	10	1.55	3.1	50	Y
			1800	10	1.9	3.2	60	Y



M <sub>n</sub> Nm	P <sub>n</sub> kW	Type	Speed 1/min	Torque Nm	Power kW	Current A	Frequency Hz	Connection
14	2.2	SHE09SA4	150	8.5	0.13	2.6	5	Y
			500	10	0.52	3.1	16.67	Y
			1000	14	1.47	4.3	33.33	Y
			1500	14	2.2	4.3	50	Y
			1800	14	2.6	4.5	60	Y
14	2.2	S5E09XA4	150	13	0.2	3.9	5	Y
			500	14	0.73	4.2	16.67	Y
			1000	14	1.47	4.2	33.33	Y
			1500	14	2.2	4.2	50	Y
			1800	14	2.6	4.5	60	Y
14	2.2	S5EU11SA6	150	14	0.22	4.4	7.5	Y
			500	-	-	-	-	Y
			1000	-	-	-	-	Y
			1500	14	2.2	4.4	75	Y
			1800	14	2.6	4.4	90	Y
19	3	S4E11SA6	150	19	0.3	5.9	7.5	Y
			500	19	1	5.9	25	Y
			1000	19	2	5.9	50	Y
			1500	19	3	5.9	75	Y
			1800	19	3.6	5.9	90	Y
20	3.1	SPE09XA4	150	13	0.2	3.9	5	Y
			500	16	0.84	4.8	16.67	Y
			1000	20	2.1	5.9	33.33	Y
			1500	20	3.1	5.9	50	Y
			1800	20	3.8	6.7	60	Y
20	3.1	S5EU11MA6	150	20	0.31	6.4	7.5	Y
			500	-	-	-	-	Y
			1000	-	-	-	-	Y
			1500	20	3.1	6.4	75	Y
			1800	20	3.8	6.4	90	Y
25.5	4	SPE11SA6	150	19	0.3	5.9	7.5	Y
			500	22	1.2	6.9	25	Y
			1000	25.5	2.7	8	50	Y
			1500	25.5	4	8	75	Y
			1800	25.5	4.8	8	90	Y
25.5	4	S5EU11LA6	150	25.5	0.4	8.1	7.5	Y
			500	-	-	-	-	Y
			1000	-	-	-	-	Y
			1500	25.5	4	8.1	75	Y
			1800	25.5	4.8	8.1	90	Y
26.5	4.2	S5E11MA6	150	26.5	0.42	8.3	7.5	Y
			500	26.5	1.4	8.3	25	Y
			1000	26.5	2.8	8.3	50	Y
			1500	26.5	4.2	8.3	75	Y
			1800	26.5	5	8.3	90	Y
35	5.5	S5E11LA6	150	35	0.55	10.8	7.5	Y
			500	35	1.8	10.8	25	Y
			1000	35	3.7	10.8	50	Y
			1500	35	5.5	10.8	75	Y
			1800	35	6.6	10.8	90	Y
35	5.5	S4E11MA6	150	26.5	0.42	8.3	7.5	Y
			500	30	1.6	9.5	25	Y
			1000	35	3.7	11	50	Y
			1500	35	5.5	11	75	Y
			1800	35	6.6	11	90	Y

# Motors - BM

## Technical data

M <sub>n</sub> Nm	P <sub>n</sub> kW	Type	Speed 1/min	Torque Nm	Power kW	Current A	Frequency Hz	Connection
48	7.5	SPE11LA6	150	35	0.55	10.8	7.5	Y
			500	40	2.1	12.3	25	Y
			1000	48	5	14.7	50	Y
			1500	48	7.5	14.7	75	Y
			1800	48	9	14.7	90	Y

### Converter Settings:

Minimum clock frequency:	3 kHz
Short-term current limit:	160 % * I <sub>1500/min</sub>
Maximum overload time:	60 s
Minimum frequency:	5 Hz
Maximum frequency:	60 Hz
Permissible operating time below f <sub>min</sub> :	60 s (in open loop mode)

All other settings must be selected according the requirements of the drive.  
The maximum overload time and the permissible operating time below f<sub>min</sub> are based on an interval of 10 minutes.

Non-standard operating conditions on request.

All motors: converter supply voltage 380 to 500 V

## Motors with rated speed 2250 1/min

M <sub>n</sub> Nm	IE Classe	Type	P <sub>n</sub> kW	I <sub>n</sub> A	2p	n <sub>n</sub> 1/min	f Hz	η %	Connection	R <sub>20</sub> Ω	R <sub>s20</sub> Ω	L <sub>d</sub> mH	L <sub>q</sub> mH	ke V/1000 1/min	kt Nm/A	M <sub>max (60s)</sub> Nm	I <sub>max (60s)</sub> A	J kgm <sup>2</sup>
3.5	5	S5EU08MA4	0.82	2.25	4	2250	75	IE5-88.4	D	6.23	9.35	34	57	103	1.4	10	6.4	0.00115
5	5	S5E08MA4	1.18	3.1	4	2250	75	IE5-87.9	D	6.23	9.35	34	57	103	1.6	10	6.4	0.00115
5	5	S5EU08LA4	1.18	3.6	4	2250	75	IE5-86.5	D	3.67	5.5	24	39	99	1.4	14	9.5	0.0015
7	4	S4E08LA4	1.65	4.7	4	2250	75	IE4-85.9	D	3.67	5.5	24	39	99	1.5	14	9.5	0.0015
7	3	SPE08MA4	1.65	4.3	4	2250	75	IE3-83.8	D	6.23	9.35	34	57	103	1.6	10	6.4	0.00115
7	5	S5EU09SA4	1.65	3.75	4	2250	75	IE5-91.3	D	3.3	4.95	21.4	36.6	120	1.85	20	11	0.00245
10	1	SSE08LA4	2.35	6.6	4	2250	75	IE1-81.4	D	3.67	5.5	24	39	99	1.5	14	9.5	0.0015
10	5	S5E09SA4	2.35	5.3	4	2250	75	IE5-89.3	D	3.3	4.95	21.4	36.6	120	1.9	20	11	0.00245
10	5	S5EU09XA4	2.35	5.5	4	2250	75	IE5-90.6	D	1.75	2.63	13.8	24.4	120	1.8	30	16	0.0038
13	3	SPE09SA4	3	6.9	4	2250	75	IE3-86.8	D	3.3	4.95	21.4	36.6	120	1.9	20	11	0.00245
17.5	4	S4E09XA4	4.1	9.2	4	2250	75	IE4-89.4	D	1.75	2.63	13.8	24.4	120	1.9	29	16	0.0038

M <sub>n</sub>	Rated torque
P <sub>n</sub>	Rated power
I <sub>n</sub>	Rated current
2p	No. of Motor Poles
n <sub>n</sub>	Rated speed
f	Nominal Frequency
η	Motor efficiency
R <sub>20</sub>	Phase Resistance U-V
R <sub>s20</sub>	Winding Resistance
L <sub>d</sub>	Inductance D-Axis
L <sub>q</sub>	Inductance Q-Axis
ke	Voltage constant
kt	Torque constant
M <sub>max (60s)</sub>	Peak Torque
I <sub>max (60s)</sub>	Peak Current
J	Moment of inertia

All motors: converter supply voltage 380 to 500 V

### Rated speed 2250 1/min

Rated speed 2250 1/min	η (100 %-Load)	η (75 %-Load)	η (50 %-Load)	IE Class	Manufacturer data	Type	Number of poles	M <sub>n</sub> Nm	P kW	Frequency Hz	Voltage V	nN 1/min	Type of motor	Operating conditions	Power losses in % at operating points (Speed/Torque)							
															25/25	25/100	50/25	50/50	50/100	90/50	90/100	90/100
88.4	n.A	n.A	n.A	5	1) S5EU08MA4	4	3.5	0.82	75	380	2250	2)	3)	1.6	8.5	2.6	4.1	9.8	6.0	12.0		
87.9	n.A	n.A	n.A	5	1) S5E08MA4	4	5	1.18	75	380	2250	2)	3)	1.1	9.9	1.7	3.5	10.8	4.9	12.3		
86.5	n.A	n.A	n.A	5	1) S5EU08LA4	4	5	1.18	75	380	2250	2)	3)	2.5	10.1	3.8	5.4	11.5	7.7	14.0		
85.9	n.A	n.A	n.A	4	1) S4E08LA4	4	7	1.65	75	380	2250	2)	3)	2.2	11.0	3.3	5.2	12.3	7.4	14.8		
83.8	n.A	n.A	n.A	3	1) SPE08MA4	4	7	1.65	75	380	2250	2)	3)	1.3	15.2	1.7	4.6	16.1	5.7	17.4		
91.3	n.A	n.A	n.A	5	1) S5EU09SA4	4	7	1.65	75	380	2250	2)	3)	1.2	6.4	2.1	3.3	7.3	3.6	8.5		
81.4	n.A	n.A	n.A	1	1) SSE08LA4	4	10	2.35	75	380	2250	2)	3)	2.2	17.6	3.0	6.2	18.6	8.1	20.5		
89.3	n.A	n.A	n.A	5	1) S5E09SA4	4	10	2.35	75	380	2250	2)	3)	1.4	8.0	1.7	3.3	9.1	4.7	10.8		
90.6	n.A	n.A	n.A	5	1) S5EU09XA4	4	10	2.35	75	380	2250	2)	3)	1.3	6.0	2.4	3.4	7.3	5.3	9.4		
86.8	n.A	n.A	n.A	3	1) SPE09SA4	4	13	3	75	380	2250	2)	3)	1.2	11.4	1.8	3.9	12.5	5.2	14.0		
89.4	n.A	n.A	n.A	4	1) S4E09XA4	4	17.5	4.1	75	380	2250	2)	3)	1.1	8.1	1.8	3.3	9.1	4.8	10.7		

\*Dimensioned according to IEC TS 60034-30-2

1) Manufacturer:	Bauer Gear Motor GmbH	2) Type of motor:	Three-phase permanent magnet excited synchronous motor	3) Installation altitude above sea level (m):	1000
Commercial register number:	HRB 736269	Ambient temperature:	-20 °C to +40 °C		
Address:	Eberhard-Bauer-Str. 37, 73734 Esslingen / Germany				

The figures given in the table below are for Bauer motors operating in conjunction with the frequency inverter. The torques referred to in tables can be entered for the respective frequencies in continuous operation (S1 = duty factor 100 %).

**Motor-Drehmomente bei Stellbereich 150 1/min - 2600 1/min, Betriebsart S1**

M <sub>n</sub> Nm	P <sub>n</sub> kW	Typ	Drehzahl 1/min	Drehmoment Nm	Leistung kW	Strom A	Frequenz Hz	Schaltung
3.5	0.82	S5EU08MA4	150	3.5	0.06	2.25	5	D
			500	-	-	-	16.66	D
			1000	-	-	-	33.33	D
			2250	3.5	0.82	2.25	75	D
			2600	3.5	1	2.25	87	D
5	1.18	S5E08MA4	150	5	0.08	3.1	5	D
			500	5	0.26	3.1	16.66	D
			1000	5	0.52	3.1	33.33	D
			2250	5	1.18	3.1	75	D
			2600	5	1.4	3.1	87	D
5	1.18	S5EU08LA4	150	5	0.08	3.6	5	D
			500	-	-	-	16.66	D
			1000	-	-	-	33.33	D
			2250	5	1.18	3.6	75	D
			2600	5	1.4	3.6	87	D
7	1.65	S4E08LA4	150	6.5	0.1	4.4	5	D
			500	7	0.37	4.7	16.66	D
			1000	7	0.73	4.7	33.33	D
			2250	7	1.65	4.7	75	D
			2600	7	1.9	4.7	87	D
7	1.65	SPE08MA4	150	5	0.08	3.1	5	D
			500	5.9	0.31	3.7	16.66	D
			1000	7	0.73	4.3	33.33	D
			2250	7	1.65	4.3	75	D
			2600	7	1.9	4.3	87	D
7	1.65	S5EU09SA4	150	7	0.11	3.75	5	D
			500	-	-	-	16.66	D
			1000	-	-	-	33.33	D
			2250	7	1.6	3.75	75	D
			2600	7	1.9	3.75	87	D
10	2.35	SSE08LA4	150	6.5	0.1	4.3	5	D
			500	8	0.42	5.3	16.66	D
			1000	10	1.05	6.6	33.33	D
			2250	10	2.35	6.6	75	D
			2600	10	2.7	6.6	87	D
10	2.35	S5E09SA4	150	8.5	0.13	4.5	5	D
			500	10	0.52	5.3	16.66	D
			1000	10	1.05	5.3	33.33	D
			2250	10	2.35	5.3	75	D
			2600	10	2.7	5.3	87	D
10	2.35	S5EU09XA4	150	10	0.16	5.5	5	D
			500	-	-	-	16.66	D
			1000	-	-	-	33.33	D
			2250	10	2.35	5.5	75	D
			2600	10	2.7	5.5	87	D
13	3	SPE09SA4	150	8.5	0.13	4.5	5	D
			500	10	0.52	5.3	16.66	D
			1000	13	1.36	6.9	33.33	D
			2250	13	3	6.9	75	D
			2600	13	3.5	6.9	87	D

# Motors - BM

## Technical data

M <sub>n</sub> Nm	P <sub>n</sub> kW	Type	Speed 1/min	Torque Nm	Power kW	Current A	Frequency Hz	Connection
17.5	4.1	S4E09XA4	150	13	0.2	6.9	5	D
			500	16	0.84	8.4	16.66	D
			1000	17.5	1.83	9.2	33.33	D
			2250	17.5	4.1	9.2	75	D
			2600	17.5	4.8	9.2	87	D

### Converter Settings:

Minimum clock frequency:	3 kHz
Short-term current limit:	160 % * I <sub>2250/min</sub>
Maximum overload time:	60 s
Minimum frequency:	5 Hz
Maximum frequency:	120 Hz
Permissible operating time below f <sub>min</sub> :	60 s (in open loop mode)

All other settings must be selected according the requirements of the drive.  
The maximum overload time and the permissible operating time below f<sub>min</sub> are based on an interval of 10 minutes.

Non-standard operating conditions on request.

All motors: converter supply voltage 380 to 500 V

## Motors with rated speed 3000 1/min

M <sub>n</sub> Nm	IE Class	Type	P <sub>n</sub> kW	I <sub>n</sub> A	2p	n <sub>n</sub> 1/min	f Hz	η %	Connection	R <sub>20</sub> Ω	R <sub>s20</sub> Ω	L <sub>d</sub> mH	L <sub>q</sub> mH	ke V/1000 1/min	kt Nm/A	M <sub>max</sub> (60s) Nm	I <sub>max</sub> (60s) A	J kgm <sup>2</sup>
0.38	5	S5EU04SA4-1	0.12	0.33	4	3000	100	IE5-82.2	Y	70.6	35.3	120	185	80	1.2	1	0.85	0.00014
0.58	5	S5EU04SA4-1	0.18	0.49	4	3000	100	IE5-80	Y	70.6	35.3	120	185	80	1.2	1	0.85	0.00014
0.65	5	S5E04SA4-1	0.2	0.52	4	3000	100	IE5-80.3	Y	70.6	35.3	120	185	80	1.25	1.6	1.3	0.00014
0.65	5	S5EU04SA4-1	0.2	0.54	4	3000	100	IE5-79.1	Y	70.6	35.3	120	185	80	1.2	1	0.85	0.00014
0.8	5	S5E04SA4-1	0.25	0.64	4	3000	100	IE5-78.5	Y	70.6	35.3	120	185	80	1.25	1.6	1.3	0.00014
0.8	5	S5EU06MA4	0.25	0.63	4	3000	100	IE5-87.8	Y	24.6	12.3	52.3	83.3	84	1.3	2.8	2.2	0.0002
1	4	S4E04SA4-1	0.315	0.8	4	3000	100	IE4-74.5	Y	70.6	35.3	120	185	80	1.25	1.6	1.3	0.00014
1.2	5	S5EU06MA4	0.37	0.93	4	3000	100	IE5-86.6	Y	24.6	12.3	52.3	83.3	84	1.3	2.8	2.2	0.0002
1.3	5	S5E06MA4	0.4	1	4	3000	100	IE5-86.2	Y	24.6	12.3	52.3	83.3	84	1.3	3.8	3	0.0002
1.3	5	S5EU06MA4	0.4	1	4	3000	100	IE5-86.3	Y	24.6	12.3	52.3	83.3	84	1.3	2.8	2.2	0.0002
1.75	5	S5E06MA4	0.55	1.35	4	3000	100	IE5-84	Y	24.6	12.3	52.3	83.3	84	1.3	3.8	3	0.0002
1.75	5	S5EU06LA4	0.55	1.45	4	3000	100	IE5-87.9	Y	11.5	5.75	29.4	40.1	80.3	1.2	3.8	3.2	0.000295
2.4	3	SPE06MA4	0.75	1.85	4	3000	100	IE3-78.6	Y	24.6	12.3	52.3	83.3	84	1.3	3.8	3	0.0002
2.4	5	S5E06LA4	0.75	1.9	4	3000	100	IE5-88.3	Y	11.5	5.75	29.4	40.1	80.3	1.25	5.6	4.5	0.000295
3.5	4	S4E06LA4	1.1	2.8	4	3000	100	IE4-84	Y	11.5	5.75	29.4	40.1	80.3	1.25	5.6	4.5	0.000295
3.5	5	S5EU08MA4	1.1	2.55	4	3000	100	IE5-90.8	Y	4.73	2.36	24.7	43.5	90	1.4	10	7.5	0.00115
5	5	S5E08MA4	1.55	3.5	4	3000	100	IE5-91.2	Y	4.73	2.36	24.7	43.5	90	1.45	10	7.5	0.00115
5	5	S5EU08LA4	1.55	3.9	4	3000	100	IE5-88.9	Y	2.82	1.41	16.8	29.6	87	1.3	15	11.2	0.0015
7	5	S5E08LA4	2.2	5.2	4	3000	100	IE5-89.2	Y	2.82	1.41	16.8	29.6	87	1.35	15	11.2	0.0015
7	4	S4E08MA4	2.2	4.8	4	3000	100	IE4-88.8	Y	4.73	2.36	24.7	43.5	90	1.45	10	7.5	0.00115
7	5	S5EU09SA4	2.2	4.45	4	3000	100	IE5-91.9	Y	2.42	1.21	15.5	27.6	103	1.6	20	12.5	0.00245
10	3	SPE08LA4	3.1	7.4	4	3000	100	IE3-86.9	Y	2.82	1.41	16.8	29.6	87	1.35	15	11.2	0.0015
10	5	S5EU09XA4	3.1	6.3	4	3000	100	IE5-92.8	Y	1.31	0.66	12.7	17.9	102	1.6	30	20	0.0038
10	5	S5EU11SA6	3.1	6.6	6	3000	150	IE5-91.5	Y	0.89	0.447	5	7.7	106	1.52	40	25	0.012
13	4	S4E09SA4	4	8	4	3000	100	IE4-89.7	Y	2.42	1.21	15.5	27.6	103	1.63	20	12.5	0.00245
12.75	5	S5EU11SA6	4	8.4	6	3000	150	IE5-91.9	Y	0.89	0.447	5	7.7	106	1.52	40	25	0.012
13	5	S5EU11MA6	4	8.6	6	3000	150	IE5-92.5	Y	0.43	0.217	3	4.6	104	1.52	55	35	0.0175
17.5	5	S5E09XA4	5.5	10.5	4	3000	100	IE5-92.5	Y	1.31	0.66	12.7	17.9	102	1.67	30	20	0.0038
17.5	4	S4E11SA6	5.5	11	6	3000	150	IE4-91.2	Y	0.89	0.447	5	7.7	106	1.55	40	25	0.012
17.5	5	S5EU11LA6	5.5	11.5	6	3000	150	IE5-91.9	Y	0.3	0.15	2.4	3.5	105	1.52	75	48	0.0215
17.5	5	S5EU11MA6	5.5	11.5	6	3000	150	IE5-93.3	Y	0.43	0.217	3	4.6	104	1.52	55	35	0.0175
20	5	S5E09XA4	6.3	12	4	3000	100	IE5-92	Y	1.31	0.66	12.7	17.9	102	1.67	30	20	0.0038
24	5	S5E11MA6	7.5	15.4	6	3000	150	IE5-93.2	Y	0.43	0.217	3	4.6	104	1.55	55	35	0.0175
24	4	S4E11SA6	7.5	15.2	6	3000	150	IE4-90.8	Y	0.89	0.447	5	7.7	106	1.55	40	25	0.012
23.9	5	S5EU11LA6	7.5	15.7	6	3000	150	IE5-93.3	Y	0.3	0.15	2.4	3.5	105	1.52	75	48	0.0215
30	5	S5E11LA6	9.5	18.5	6	3000	150	IE5-93.8	Y	0.3	0.15	2.4	3.5	105	1.6	75	48	0.0215
30	5	S5E11MA6	9.5	19.3	6	3000	150	IE5-93.2	Y	0.43	0.217	3	4.6	104	1.55	55	35	0.0175
35	5	S5E11LA6	11	21.5	6	3000	150	IE5-94.1	Y	0.3	0.15	2.4	3.5	105	1.6	75	48	0.0215
35	4	S4E11MA6	11	22.5	6	3000	150	IE4-93.1	Y	0.43	0.217	3	4.6	104	1.55	55	35	0.0175
48	5	S5E11LA6	15	30	6	3000	150	IE5-93.8	Y	0.3	0.15	2.4	3.5	105	1.6	75	48	0.0215

M <sub>n</sub>	Rated torque
P <sub>n</sub>	Rated power
I <sub>n</sub>	Rated current
2p	No. of Motor Poles
n <sub>n</sub>	Rated speed
f	Nominal Frequency
η	Motor efficiency
R <sub>20</sub>	Phase Resistance U-V
R <sub>s20</sub>	Winding Resistance
L <sub>d</sub>	Inductance D-Axis
L <sub>q</sub>	Inductance Q-Axis
ke	Voltage constant
kt	Torque constant
M <sub>max</sub> (60s)	Peak Torque
I <sub>max</sub> (60s)	Peak Current
J	Moment of inertia

All motors: converter supply voltage 380 to 500 V

Rated speed 3000 1/min

Rated speed 3000 1/min	η (100 %-Load)	η (75 %-Load)	η (50 %-Load)	IE Class	Manufacturer data	Type	Number of poles	M <sub>n</sub> Nm	P kW	Frequency Hz	Voltage V	n <sub>n</sub> 1/min	Type of motor	Operating conditions	Power losses in % at operating points (Speed/Torque)						
															25/25	25/100	50/25	50/50	50/100	90/50	90/100
82.2	n.A	n.A	n.A	5	1)	S5EU04SA4-1	4	0.38	0.12	100	380	3000	2)	3)	3.5	12.5	6.0	7.9	15.1	12.1	19.5
80	n.A	n.A	n.A	5	1)	S5EU04SA4-1	4	0.58	0.18	100	380	3000	2)	3)	3.0	18.0	4.5	7.8	19.8	10.9	22.8
80.3	n.A	n.A	n.A	5	1)	S5E04SA4-1	4	0.65	0.2	100	380	3000	2)	3)	2.9	17.7	4.5	7.7	19.5	11.0	22.6
79.1	n.A	n.A	n.A	5	1)	S5EU04SA4-1	4	0.65	0.2	100	380	3000	2)	3)	2.8	20.1	4.1	7.8	21.8	10.3	24.3
78.5	n.A	n.A	n.A	5	1)	S5E04SA4-1	4	0.8	0.25	100	380	3000	2)	3)	2.6	20.7	3.9	7.6	22.3	10.5	24.8
78.8	n.A	n.A	n.A	5	1)	S5EU06MA4	4	0.8	0.25	100	380	3000	2)	3)	2.1	7.8	3.8	5.0	9.5	8.2	12.6
74.5	n.A	n.A	n.A	4	1)	S4E04SA4-1	4	1	0.315	100	380	3000	2)	3)	2.8	27.2	3.8	8.9	28.5	11.7	30.9
86.6	n.A	n.A	n.A	5	1)	S5EU06MA4	4	1.2	0.37	100	380	3000	2)	3)	1.8	11.0	3.0	4.8	12.1	7.1	14.2
86.2	n.A	n.A	n.A	5	1)	S5E06MA4	4	1.3	0.4	100	380	3000	2)	3)	1.7	10.5	3.0	4.9	11.8	7.9	14.7
86.3	n.A	n.A	n.A	5	1)	S5EU06MA4	4	1.3	0.4	100	380	3000	2)	3)	1.7	11.6	2.7	4.7	12.7	6.6	14.6
84	n.A	n.A	n.A	5	1)	S5E06MA4	4	1.75	0.55	100	380	3000	2)	3)	1.6	14.0	2.5	5.0	15.0	7.3	17.2
87.9	n.A	n.A	n.A	5	1)	S5EU06LA4	4	1.75	0.55	100	380	3000	2)	3)	1.8	8.8	3.0	4.5	10.2	6.7	12.5
78.6	n.A	n.A	n.A	3	1)	SPE06MA4	4	2.4	0.75	100	380	3000	2)	3)	1.8	22.3	2.6	6.5	22.9	8.3	24.7
88.3	n.A	n.A	n.A	5	1)	S5E06LA4	4	2.4	0.75	100	380	3000	2)	3)	1.2	9.6	1.8	3.4	10.2	5.1	11.9
84	n.A	n.A	n.A	4	1)	S4E06LA4	4	3.5	1.1	100	380	3000	2)	3)	1.3	15.3	1.9	4.4	16.0	5.7	17.2
90.8	n.A	n.A	n.A	5	1)	S5EU08MA4	4	3.5	1.1	100	380	3000	2)	3)	1.5	6.2	2.4	3.4	7.2	5.3	9.1
91.2	n.A	n.A	n.A	5	1)	S5E08MA4	4	5	1.55	100	380	3000	2)	3)	0.9	6.7	1.4	2.6	7.3	4.1	8.8
88.9	n.A	n.A	n.A	5	1)	S5EU08LA4	4	5	1.55	100	380	3000	2)	3)	1.9	7.0	3.3	4.5	8.7	7.1	11.5
89.2	n.A	n.A	n.A	5	1)	S5E08LA4	4	7	2.2	100	380	3000	2)	3)	1.4	7.2	2.5	3.8	8.5	6.0	10.9
88.8	n.A	n.A	n.A	4	1)	S4E08MA4	4	7	2.2	100	380	3000	2)	3)	0.9	9.7	1.3	3.1	10.2	4.1	11.3
91.9	n.A	n.A	n.A	5	1)	S5EU09SA4	4	7	2.2	100	380	3000	2)	3)	1.1	5.2	2.1	3.0	6.2	4.6	7.9
86.9	n.A	n.A	n.A	3	1)	SPE08LA4	4	10	3.1	100	380	3000	2)	3)	1.5	10.7	2.4	4.4	11.8	6.3	13.8
92.8	n.A	n.A	n.A	5	1)	S5EU09XA4	4	10	3.1	100	380	3000	2)	3)	1.3	4.2	2.2	2.8	5.3	4.7	7.1
91.5	n.A	n.A	n.A	5	1)	S5EU11SA6	6	10	3.1	150	380	3000	2)	3)	1.4	3.7	3.0	3.5	5.4	6.6	8.5
89.7	n.A	n.A	n.A	4	1)	S4E09SA4	4	13	4	100	380	3000	2)	3)	1.1	8.0	1.8	3.2	8.9	4.8	10.6
91.9	n.A	n.A	n.A	5	1)	S5EU11SA6	6	12.75	4	150	380	3000	2)	3)	1.2	4.2	2.4	3.1	5.6	5.5	8.0
92.5	n.A	n.A	n.A	5	1)	S5EU11MA6	6	13	4	150	380	3000	2)	3)	1.5	2.8	3.2	3.3	4.5	6.3	7.5
92.5	n.A	n.A	n.A	5	1)	S5E09XA4	4	17.5	5.5	100	380	3000	2)	3)	0.8	5.1	1.5	2.4	5.9	4.0	7.3
91.2	n.A	n.A	n.A	4	1)	S4E11SA6	6	17.5	5.5	150	380	3000	2)	3)	1.0	4.4	2.2	3.0	5.7	5.9	8.7
91.9	n.A	n.A	n.A	5	1)	S5EU11LA6	6	17.5	5.5	150	380	3000	2)	3)	1.3	2.3	3.0	3.1	4.0	7.1	7.9
93.3	n.A	n.A	n.A	5	1)	S5EU11MA6	6	17.5	5.5	150	380	3000	2)	3)	1.1	3.0	2.3	2.6	4.2	4.7	6.5
92	n.A	n.A	n.A	5	1)	S5E09XA4	4	20	6.3	100	380	3000	2)	3)	0.8	5.9	1.4	2.4	6.5	3.7	7.8
93.2	n.A	n.A	n.A	5	1)	S5E11MA6	6	24	7.5	150	380	3000	2)	3)	0.9	2.9	1.9	2.4	4.1	4.8	6.6
90.8	n.A	n.A	n.A	4	1)	S4E11SA6	6	24	8	150	380	3000	2)	3)	0.9	5.9	1.8	2.8	7.0	5.0	9.2
93.3	n.A	n.A	n.A	5	1)	S5EU11LA6	6	24	8	150	380	3000	2)	3)	1.0	2.3	2.2	2.5	3.6	5.3	6.5
93.8	n.A	n.A	n.A	5	1)	S5E11LA6	6	30	10	150	380	3000	2)	3)	0.8	2.5	1.7	2.2	3.5	4.4	5.9
93.2	n.A	n.A	n.A	5	1)	S5E11MA6	6	30	10	150	380	3000	2)	3)	0.8	3.4	1.6	2.2	4.4	4.2	6.6



### Rated speed 3000 1/min

Rated speed 3000 1/min	Power losses in % at operating points (Speed/Torque)																				
	$\eta$ (100 %-Load)	$\eta$ (75 %-Load)	$\eta$ (50 %-Load)	IE Class	Manufacturer data	Type	Number of poles	$M_n$	P	Frequency	Voltage	nN	Type of motor	Operating conditions	25/25	25/100	50/25	50/50	50/100	90/50	90/100
94.1	n.A	n.A	n.A	5	1) S5E11LA6		6	35	11	150	380	3000	2)	3)	0.7	2.8	1.6	2.0	3.7	3.9	5.7
93.1	n.A	n.A	n.A	4	1) S4E11MA6		6	35	11	150	380	3000	2)	3)	0.7	3.9	1.5	2.1	4.8	3.9	6.7
93.8	n.A	n.A	n.A	5	1) S5E11LA6		6	48	15	150	380	3000	2)	3)	0.7	3.6	1.3	1.9	4.4	3.3	6.0

\*Dimensioned according to IEC TS 60034-30-2

1) Manufacturer:	Bauer Gear Motor GmbH	2) Type of motor:	Three-phase permanent magnet excited synchronous motor	3) Installation altitude above sea level (m):	1000
Commercial register number:	HRB 736269	Ambient temperature:	-20 °C to +40 °C		
Address:	Eberhard-Bauer-Str. 37, 73734 Esslingen / Germany				

# Motors - BM

## Technical data

The figures given in the table below are for Bauer motors operating in conjunction with the frequency inverter. The torques referred to in tables can be entered for the respective frequencies in continuous operation (S1 = duty factor 100 %).

### Motor torques in the adjusting range 150 1/min - 3600 1/min, duty type S1

M <sub>n</sub> Nm	P <sub>n</sub> kW	Type	Speed 1/min	Torque Nm	Power kW	Current A	Frequency Hz	Connection
0.38	0.12	S5EU04SA4-1	150	0.38	0.006	0.33	5	Y
			500	0.38	0.02	0.33	16.67	Y
			1000	0.38	0.04	0.33	33.33	Y
			3000	0.38	0.12	0.33	100	Y
			3600	0.38	0.14	0.33	120	Y
0.58	0.18	S5EU04SA4-1	150	0.58	0.009	0.49	5	Y
			500	0.58	0.03	0.49	16.67	Y
			1000	0.58	0.06	0.49	33.33	Y
			3000	0.58	0.18	0.49	100	Y
			3600	0.58	0.22	0.49	120	Y
0.65	0.2	S5E04SA4-1	150	0.65	0.01	0.52	5	Y
			500	0.65	0.034	0.52	16.67	Y
			1000	0.65	0.068	0.52	33.33	Y
			3000	0.65	0.2	0.52	100	Y
			3600	0.65	0.245	0.52	120	Y
0.65	0.2	S5EU04SA4-1	150	0.65	0.01	0.54	5	Y
			500	0.65	0.034	0.54	16.67	Y
			1000	0.65	0.068	0.54	33.33	Y
			3000	0.65	0.2	0.54	100	Y
			3600	0.65	0.245	0.54	120	Y
0.8	0.25	S5E04SA4-1	150	0.76	0.012	0.61	5	Y
			500	0.8	0.042	0.64	16.67	Y
			1000	0.8	0.084	0.64	33.33	Y
			3000	0.8	0.25	0.64	100	Y
			3600	0.8	0.3	0.64	120	Y
0.8	0.25	S5EU06MA4	150	0.8	0.013	0.63	5	Y
			500	0.8	0.042	0.63	16.67	Y
			1000	0.8	0.084	0.63	33.33	Y
			3000	0.8	0.25	0.63	100	Y
			3600	0.8	0.3	0.63	120	Y
1	0.315	S4E04SA4-1	150	0.76	0.012	0.61	5	Y
			500	0.85	0.045	0.68	16.67	Y
			1000	1	0.105	0.8	33.33	Y
			3000	1	0.315	0.8	100	Y
			3600	1	0.38	0.8	120	Y
1.2	0.37	S5EU06MA4	150	1.2	0.019	0.93	5	Y
			500	1.2	0.063	0.93	16.67	Y
			1000	1.2	0.126	0.93	33.33	Y
			3000	1.2	0.37	0.93	100	Y
			3600	1.2	0.45	0.93	120	Y
1.3	0.4	S5E06MA4	150	1.3	0.02	1	5	Y
			500	1.3	0.068	1	16.67	Y
			1000	1.3	0.136	1	33.33	Y
			3000	1.3	0.4	1	100	Y
			3600	1.3	0.5	1	120	Y
1.3	0.4	S5EU06MA4	150	1.3	0.02	1	5	Y
			500	1.3	0.068	1	16.67	Y
			1000	1.3	0.136	1	33.33	Y
			3000	1.3	0.4	1	100	Y
			3600	1.3	0.5	1	120	Y

M <sub>n</sub> Nm	P <sub>n</sub> kW	Type	Speed 1/min	Torque Nm	Power kW	Current A	Frequency Hz	Connection
1.75	0.55	S5E06MA4	150	1.75	0.027	1.35	5	Y
			500	1.75	0.092	1.35	16.67	Y
			1000	1.75	0.183	1.35	33.33	Y
			3000	1.75	0.55	1.35	100	Y
			3600	1.75	0.66	1.35	120	Y
1.75	0.55	S5EU06LA4	150	1.75	0.027	1.45	5	Y
			500	1.75	0.092	1.45	16.67	Y
			1000	1.75	0.183	1.45	33.33	Y
			3000	1.75	0.55	1.45	100	Y
			3600	1.75	0.66	1.45	120	Y
2.4	0.75	SPE06MA4	150	1.8	0.028	1.38	5	Y
			500	2	0.105	1.51	16.67	Y
			1000	2.2	0.23	1.68	33.33	Y
			3000	2.4	0.75	1.85	100	Y
			3600	2.4	0.9	1.85	120	Y
2.4	0.75	S5E06LA4	150	2.4	0.038	1.9	5	Y
			500	2.4	0.126	1.9	16.67	Y
			1000	2.4	0.25	1.9	33.33	Y
			3000	2.4	0.75	1.9	100	Y
			3600	2.4	0.9	1.9	120	Y
3.5	1.1	S4E06LA4	150	2.5	0.04	2	5	Y
			500	2.9	0.15	2.3	16.67	Y
			1000	3.5	0.37	2.8	33.33	Y
			3000	3.5	1.1	2.8	100	Y
			3600	3.5	1.3	2.8	120	Y
3.5	1.1	S5EU08MA4	150	3.5	0.06	2.55	5	Y
			500	-	-	-	16.67	Y
			1000	-	-	-	33.33	Y
			3000	3.5	1.1	2.55	100	Y
			3600	3.5	1.3	2.55	120	Y
5	1.55	S5E08MA4	150	5	0.08	3.5	5	Y
			500	5	0.26	3.5	16.67	Y
			1000	5	0.52	3.5	33.33	Y
			3000	5	1.55	3.5	100	Y
			3600	5	1.9	3.5	120	Y
5	1.55	S5EU08LA4	150	5	0.08	3.9	5	Y
			500	-	-	-	16.67	Y
			1000	-	-	-	33.33	Y
			3000	5	1.55	3.9	100	Y
			3600	5	1.9	3.9	120	Y
7	2.2	S5E08LA4	150	6.5	0.1	4.8	5	Y
			500	7	0.37	5.2	16.67	Y
			1000	7	0.73	5.2	33.33	Y
			3000	7	2.2	5.2	100	Y
			3600	7	2.6	5.2	120	Y
7	2.2	S4E08MA4	150	5	0.08	3.5	5	Y
			500	5.9	0.31	4.1	16.67	Y
			1000	7	0.73	4.8	33.33	Y
			3000	7	2.2	4.8	100	Y
			3600	7	2.6	4.8	120	Y
7	2.2	S5EU09SA4	150	7	0.11	4.45	5	Y
			500	-	-	-	16.67	Y
			1000	-	-	-	33.33	Y
			3000	7	2.2	4.45	100	Y
			3600	7	2.6	4.45	120	Y

# Motors - BM

## Technical data

M <sub>n</sub> Nm	P <sub>n</sub> kW	Type	Speed 1/min	Torque Nm	Power kW	Current A	Frequency Hz	Connection
10	3.1	SPE08LA4	150	6.5	0.1	4.8	5	Y
			500	8	0.42	5.9	16.67	Y
			1000	10	1.05	7.4	33.33	Y
			3000	10	3.1	7.4	100	Y
			3600	10	3.8	7.4	120	Y
10	3.1	S5EU09XA4	150	10	0.16	6.3	5	Y
			500	-	-	-	16.67	Y
			1000	-	-	-	33.33	Y
			3000	10	3.1	6.3	100	Y
			3600	10	3.8	6.3	120	Y
10	3.1	S5EU11SA6	150	10	0.16	6.6	7.5	Y
			500	-	-	-	25	Y
			1000	-	-	-	50	Y
			3000	10	3.1	6.6	150	Y
			3600	10	3.8	6.6	180	Y
13	4	S4E09SA4	150	8.5	0.13	5.3	5	Y
			500	10	0.52	6.2	16.67	Y
			1000	13	1.36	8	33.33	Y
			3000	13	4	8	100	Y
			3600	13	4.9	8.7	120	Y
12.75	4	S5EU11SA6	150	12.75	0.2	8.4	7.5	Y
			500	-	-	-	25	Y
			1000	-	-	-	50	Y
			3000	12.75	4	8.4	150	Y
			3600	12.75	4.8	8.4	180	Y
13	4	S5EU11MA6	150	13	0.2	8.6	7.5	Y
			500	-	-	-	25	Y
			1000	-	-	-	50	Y
			3000	13	4	8.6	150	Y
			3600	13	4.9	8.6	180	Y
17.5	5.5	S5E09XA4	150	13	0.2	7.8	5	Y
			500	16	0.84	9.6	16.67	Y
			1000	17.5	1.83	10.5	33.33	Y
			3000	17.5	5.5	10.5	100	Y
			3600	17.5	6.6	11.1	120	Y
17.5	5.5	S4E11SA6	150	17.5	0.27	11	7.5	Y
			500	17.5	0.9	11	25	Y
			1000	17.5	1.8	11	50	Y
			3000	17.5	5.5	11	150	Y
			3600	17.5	6.6	11	180	Y
17.5	5.5	S5EU11MA6	150	17.5	0.27	11.5	7.5	Y
			500	-	-	-	25	Y
			1000	-	-	-	50	Y
			3000	17.5	5.5	11.5	150	Y
			3600	17.5	6.6	11.5	180	Y
17.5	5.5	S5EU11LA6	150	17.5	0.27	11.5	7.5	Y
			500	-	-	-	25	Y
			1000	-	-	-	50	Y
			3000	17.5	5.5	11.5	150	Y
			3600	17.5	6.6	11.5	180	Y
20	6.3	S5E09XA4	150	13	0.2	7.8	5	Y
			500	16	0.84	9.6	16.67	Y
			1000	20	2.1	12	33.33	Y
			3000	20	6.3	12	100	Y
			3600	17.5	6.6	11.1	120	Y

M <sub>n</sub> Nm	P <sub>n</sub> kW	Type	Speed 1/min	Torque Nm	Power kW	Current A	Frequency Hz	Connection
24	7.5	S4E11SA6	150	19	0.3	12	7.5	Y
			500	21.5	1.1	13.6	25	Y
			1000	24	2.5	15.2	50	Y
			3000	24	7.5	15.2	150	Y
			3600	24	9	15.2	180	Y
24	7.5	S5E11MA6	150	24	0.38	15.4	7.5	Y
			500	24	1.3	15.4	25	Y
			1000	24	2.5	15.4	50	Y
			3000	24	7.5	15.4	150	Y
			3600	24	9	15.4	180	Y
23.9	7.5	S5EU11LA6	150	23.9	0.38	15.7	7.5	Y
			500	-	-	-	25	Y
			1000	-	-	-	50	Y
			3000	23.9	7.5	15.7	150	Y
			3600	23.9	9	15.7	180	Y
30	9.5	S5E11MA6	150	26.5	0.42	17	7.5	Y
			500	30	1.6	19.3	25	Y
			1000	30	3.1	19.3	50	Y
			3000	30	9.5	19.3	150	Y
			3600	30	11	19.3	180	Y
30	9.5	S5E11LA6	150	30	0.47	18.5	7.5	Y
			500	30	1.6	18.5	25	Y
			1000	30	3.1	18.5	50	Y
			3000	30	9.5	18.5	150	Y
			3600	30	11	18.5	180	Y
35	11	S4E11MA6	150	26.5	0.42	17	7.5	Y
			500	30	1.6	19.3	25	Y
			1000	35	3.7	22.5	50	Y
			3000	35	11	22.5	150	Y
			3600	35	13	22.5	180	Y
35	11	S5E11LA6	150	35	0.55	21.5	7.5	Y
			500	35	1.8	21.5	25	Y
			1000	35	3.7	21.5	50	Y
			3000	35	11	21.5	150	Y
			3600	35	13	21.5	180	Y
48	15	S5E11LA6	150	35	0.55	21.5	7.5	Y
			500	40	2.1	25	25	Y
			1000	48	5	30	50	Y
			3000	48	15	30	150	Y
			3600	40	15	25.8	180	Y

**Converter Settings:**

Minimum clock frequency:	3 kHz
Short-term current limit:	160 % * I <sub>3000/min</sub>
Maximum overload time:	60 s
Minimum frequency:	5 Hz
Maximum frequency:	120 Hz
Permissible operating time below f <sub>min</sub> :	60 s (in open loop mode)

All other settings must be selected according the requirements of the drive.  
The maximum overload time and the permissible operating time below f<sub>min</sub> are based on an interval of 10 minutes.

Non-standard operating conditions on request.

All motors: converter supply voltage 380 to 500 V

# Energy Efficient Geared Motors

## Electric overhead conveyors series BM

---

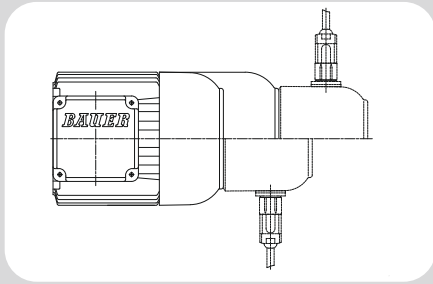

# 13

## Motor Mounted Components

<b>Brake .....</b>	<b>229</b>
Functional description .....	229
Product description of type ES(X) spring-actuated brakes .....	229
Product description of type ZS(X) spring-actuated brakes .....	230
Brake selection and sizing .....	231
Electrical connection .....	234
Specifications of holding brakes with emergency stop capability .....	237
Specifications of working brakes .....	238
Connection .....	240
DC connection via terminals (K) .....	240
Standard rectifier (S) .....	241
Rectifier for electronic rapid shutdown (E) .....	242
Rectifier for overexcitation and rapid shutdown (M) .....	243
Brake connection, operation with frequency converter .....	245
Brake connection, pole-changing motors .....	245
Manual release (HA, HN) .....	245
Explosion protection .....	245
Back stop (RR, RL) .....	245
Second motor shaft extension (ZW, ZV) .....	246
Protective fan cowl (D) .....	246
Motor-independent fan (FV) .....	246
Technical Data Motor-independent fan .....	246
<b>Encoder System .....</b>	<b>247</b>
Shaft encoder (G) .....	247
<b>Incremental rotary encoder .....</b>	<b>248</b>
Functional description .....	248
Electrical specifications .....	248
Plug end view with male pin insert .....	248
Signal assignments .....	248
Functional description .....	249
Profibus DP interface .....	249
<b>Absolute rotary encoders .....</b>	<b>250</b>
SSI interface .....	250

# Energy Efficient Geared Motors

## Electric overhead conveyors series BM

---



### Functional description

The compression springs act on the anchor disc, which is free to move in the axial direction and presses the brake disc, which is keyed to the rotor shaft, against the friction plate or the motor bearing plate. This produces the braking torque.

When a DC voltage is applied to the coil in the electromagnet housing, it generates a magnetic force that opposes the spring force and causes the anchor disc to be pulled toward the electromagnet enclosure.

This releases the brake disc and disengages the brake.

Brakes are classified into two types according to how they are used: holding brakes and working brakes.

### Holding brake ES.. / ZS..

brake that in normal operation does not convert kinetic energy into frictional energy but is only used to hold a mechanism in a particular position, but which can also be used for motion braking in an emergency.

### Service brake ESX.. / ZSX..

A brake that converts kinetic energy into frictional energy in normal operation, which means that it brakes mechanical motion.

When a working brake is used as a holding brake, the braking torque tolerance of up to -30 % (in new condition) must be taken into account.

### Product description of type ES(X) spring-actuated brakes

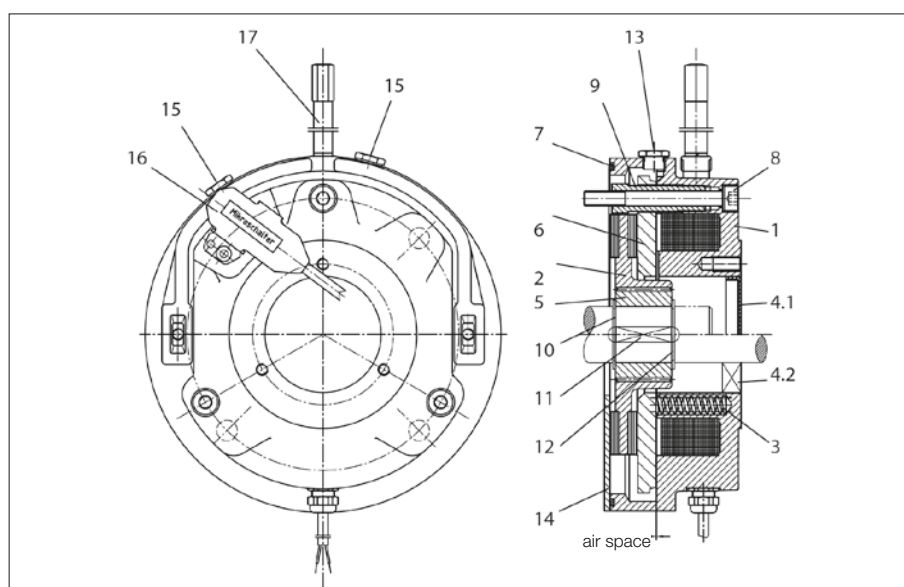

Figure 1: Construction of ES(X) brake

### Construction of ES(X) brake

1	Electromagnet housing	9	Hollow screw
2	Brake disc	10	Retaining ring
3	Compression spring	11	Key
4.1	Cover plate with closed brake	12	Retaining ring
4.2	Shaft seal with through shaft	13	Screw plug for checking air gap
5	Drive bush	14	Friction plate (only with motor size Dxx08 or Dxx09)
6	Anchor disc	15	Screw plug for checking microswitch setting
7	O-ring	16	Microswitch (optional)
8	Fitting screw with copper washer	17	Manual release (optional)

### Brake mounting

ES and ESX: Brake mounting is under the fan cover

EH and EHX: Brake mounting is on the fan cover

### Options

- Manual release, non-locking or locking
- Microswitch for monitoring operation or wear

# Motor Mounted Components

## Brake

### Product description of type ZS(X) spring-actuated brakes

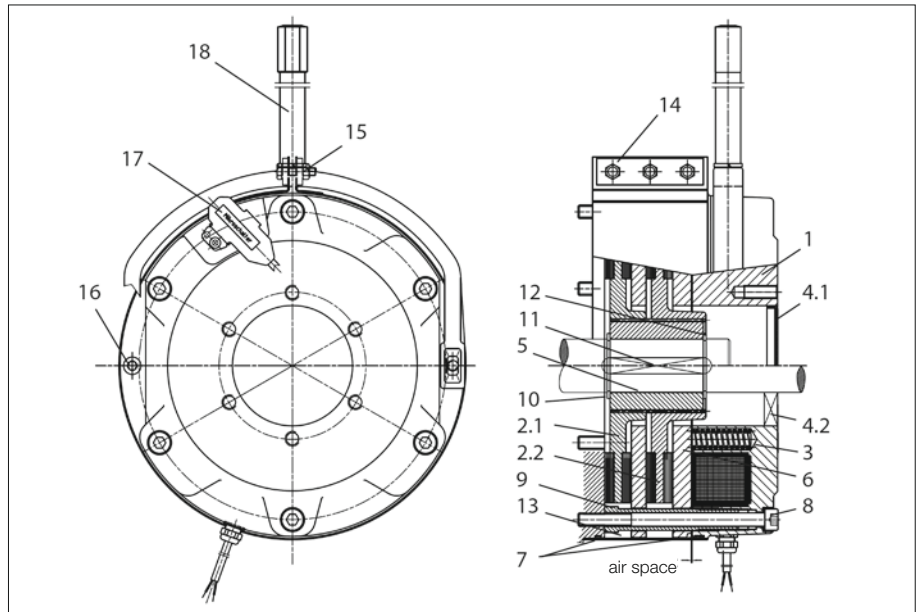

Figure 2: Construction of ZS(X) brake

### Construction of ZS(X) brake

1	Electromagnet housing	9	Hollow screw
2.1	Brake disc	10	Retaining ring
2.2	Brake disc	11	Key
3	Compression spring	12	Retaining ring
4.1	Cover plate	13	Cover
4.2	Shaft seal with through shaft	14	Fitting screws
5	Drive bush	15	Bracket
6	Anchor disc	16	Assembly screw/assembly aid
7	O-ring	17	Microswitch (optional)
8	Fitting screw with copper washer	18	Manual release (optional)

### Options

- Manual release, non-locking or locking
- Microswitch for monitoring operation or wear

### Brake selection and sizing

If the working brake is undersized, it will have increased wear and a shorter lifetime. If it is oversized, the resulting mechanical forces may overload the drive.

If specific application data is not available, in the case of horizontally driven equipment we recommend selecting a braking torque with a safety factor (K) of 1 to 1.5 times the rated torque of the motor.

For braking to standstill, the selected braking torque should be at least 80 % of the rated torque of the drive.

Rated torque:

$$M_{\text{Berf}} = \frac{P \times 9550}{n_2} \times K$$

$M_{\text{Berf}}$	Braking torque	[Nm]
P	Motor power	[kW]
n	Rated speed at rotor shaft	[rpm]

For lifting operation, a braking torque equal to twice the rated motor torque should always be chosen for safety reasons.

If the moment of inertia, speed and allowable deceleration time of the machine are known, the braking torque can be calculated as described below.

### External moments of inertia

**If the masses to be decelerated by the brake do not run at the same speed as the rotor shaft, the moment of inertia ( $J_{\text{ext}}$ ) must be reduced to the value at the rotor shaft**

$$J_{\text{ext}'} = \frac{J_{\text{ext}1} \times n_1^2 + J_{\text{ext}2} \times n_2^2 + \dots + J_{\text{ext}n} \times n_n^2}{i^2}$$

or the external moment of inertia reduced by the gear ratio of the gear unit to the value at the rotor shaft.

$$J_{\text{ext}'} = \frac{J_{\text{ext}}}{i^2}$$

$J_{\text{ext}}$	Total external moment of inertia [kgm <sup>2</sup> ]
$J_{\text{ext}'}$	Total external moment of inertia referenced to the rotor shaft [kgm <sup>2</sup> ]
$J_{\text{ext}1,2,\dots}$	Individual external moments of inertia [kgm <sup>2</sup> ]
i	Gear reduction ratio
n	Rotor shaft speed
$n_{1,2,\dots}$	Speeds of the individual moments of inertia [rpm]

Load torque under static load

$$M_L = F \times r$$

$M_L$	Load torque [Nm]
F	Force [N]
r	radius [m]

### Braking torque with dynamic load

A purely dynamic load is present when flywheels, rolls, etc. must be decelerated and the static load torque is negligible.

$$M_a = \frac{J_{ges} \times n_a}{9,55 \times (t_a - t_A)} = \frac{(J_{ext} + J_{rot} + J_{Br}) \times n_a}{9,55 \times (t_a - t_A)}$$

$J_{br}$	Moment of inertia of the brake [kgm <sup>2</sup> ]
$J_{rot}$	Moment of inertia of the rotor shaft and rotor [kgm <sup>2</sup> ]
$M_a$	Deceleration torque [Nm]
$n_a$	Initial speed at start of deceleration [rpm]
$t_a$	Total deceleration time (from switch-off until drive is stationary) [s]
$t_A$	The response time of the brake for braking corresponds to $t_{AC}$ or $t_{DC}$ in the specification tables [s]

### Dynamic and static loads

In most application situations, both static and dynamic loads are present.

$$M_{Berf} = (M_a \pm M_L) \times K \quad \text{where} \quad M_{Berf} \leq M_{Br} \quad \text{must hold true.}$$

$M_L$  braking (positive) or driving (negative) load torque [Nm]

### Heat generated by each brake cycle

Friction converts the kinetic energy of the moving masses into heat.

This amounts to

$$W = \frac{J_{ges} \times n^2}{182,5} = \frac{(J_{ext} + J_{rot} + J_{Br}) \times n_a^2}{182,5} \quad \text{where} \quad W \leq W_{max} \quad \text{must hold true.}$$

$W$	Braking energy for each brake cycle [J]
$M_{max}$	Maximum permissible frictional energy per brake cycle (see brake tables)

### Thermally allowable braking energy of working brakes

With a uniform sequence of brake cycles, which means a certain average number of brake cycles per hour, the temperature rises until an equilibrium between heat input and heat dissipation is reached. The temperature rise must be sized to avoid overheating the coil and the friction layer, taking the ambient temperature into account.

#### Braking to standstill:

$$W_z = W \times Z \leq W_{th}$$

$W_{th}$  Maximum allowable braking energy per hour

$W_z$  Braking energy with Z brake cycles

Z Number of brake cycles per hour

#### Lifting operation

In lowering operation, the drive motor acts as a generator and its braking effect results in a steady downward motion (constant speed). If we ignore transmission losses, under full load the drive must brake the load with the rated motor torque. If a mechanical brake with a braking torque equal to the braking torque of the motor is applied after the drive is switched off, the downward motion will continue at the same speed. This means that additional braking torque is necessary to stop the motion of the load. For example, if the brake is dimensioned for 200 % braking torque, approximately 100 % is used for "static" deceleration and the rest is used for "dynamic" deceleration.

If part of the braking torque is required for braking the load during lowering (downward motion), the brake engagement time is greater, and the thermal load is therefore greater.

In this case

$$W_H = \frac{M_{Br}}{M_{Br} - M_L} \times W_z$$

$W_H$  Friction energy per hour in lifting operation

$M_{Br}$  Braking torque of the brake

#### Brake lifetime

The energy absorbed during braking causes the brake disc to wear, which increases the air gap. If the air gap increases beyond a certain maximum gap size, the magnetic field is so weak that the pulling force of the electromagnet is no longer sufficient to release the brake. A proper air gap must be restored by adjusting the air gap or by replacing the brake disc, depending on the type of brake construction.

The maximum number of brake cycles until service is necessary can be calculated as follows:

$$Z_L = \frac{W_L}{W}$$

$Z_L$  Number of brake cycles until the air gap limit is reached

$W_L$  Maximum allowable braking energy until maintenance; i.e. replacing the brake disc or adjusting the air gap. Adjustment of the air gap is possible only with type ZXSxx brakes.

#### Deceleration time

The pure braking time from the start of mechanical braking to standstill depends on the braking deceleration.

Especially with lifting operation, but also in other types of operation, it is necessary to check whether the load torque reinforces the braking effect or counters the braking effect.

The deceleration time is therefore calculated as follows:

$$t_a = \frac{J_{ges} \times n_a}{9,55 \times (M_{Br} \pm M_L)}$$

# Motor Mounted Components

## Brake

### Electrical connection

### General

There are two basic options for providing the supply voltage for the DC electromagnet:

1. Externally from an existing DC control voltage mains or a rectifier in the cabinet.
2. From a rectifier built into the motor or brake terminal box. In this case, the rectifier can be powered either directly from the motor terminal board or from the mains.

Note that in the following cases the rectifier is not allowed to be connected to the terminal board of the motor:

- Pole-changing motors and motors with wide operating voltage range
- Operation from a frequency converter
- Other configurations in which the motor voltage is not constant, such as operation with soft-start devices, start-up transformers, etc.

### Release

When the rated voltage is applied to the electromagnet coil, the current through the coils increases exponentially and with it the generated magnetic field. The current must rise to a certain value ( $I_{\text{release}}$ ) before it overcomes the spring force and starts to release the brake.

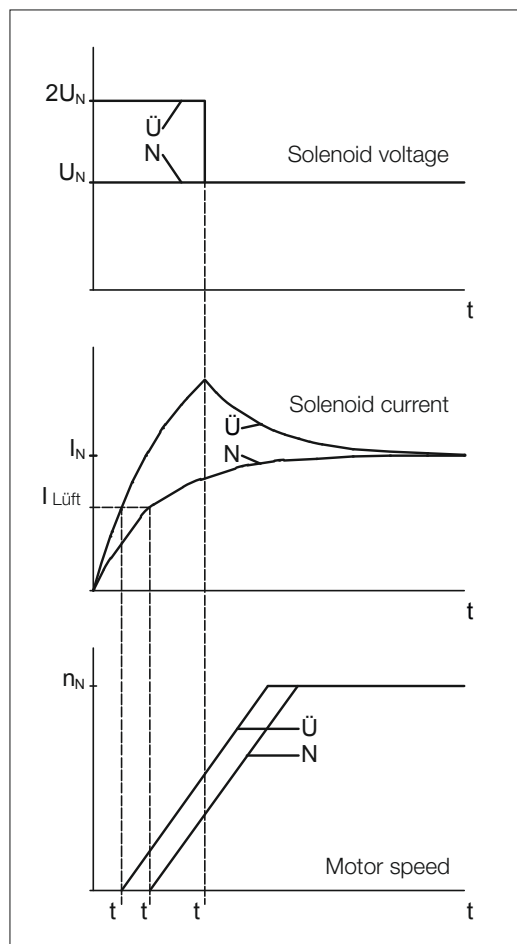

Figure 3: Idealised curves of coil voltage, coil current and motor speed with normal excitation (N) and overexcitation (Ü).

$t_U$ : overexcitation time;  $t_{AN}$ ,  $t_{AU}$ : Response time with normal excitation and overexcitation.

Two different situations can arise during the response time  $t_A$ , assuming that the voltage is applied to the motor and the brake simultaneously:

- The motor is locked if  $M_A < M_L + M_{Br}$   
The motor draws its locked-rotor current, which increases the thermal load on the motor. This situation is illustrated in Figure 3.
- The brake slips if  $M_A > M_L + M_{Br}$   
In this case, the brake is also thermally stressed during start-up and wears faster.

$M_A$ : locked rotor torque of the motor;  $M_L$ : load torque;  $M_{Br}$ : braking torque

As can be seen, there is an additional load on the motor and brake in both cases. The effect of the response time increases with increasing brake size. Consequently, it is advisable to reduce the response time, especially with medium-sized and large brakes and with a high cycle rate. This can be achieved relatively easily by means of electrical overexcitation. With this approach, the coil is briefly operated at twice its rated voltage after switch-on.

This causes the current to rise faster than with normal excitation, and it reduces the response time by approximately 50 %. This overexcitation function is built into the type MSG special rectifier.

The release current increases with increasing air gap, and with it the response time. When the release current exceeds the rated coil current, the brake will not be released with normal excitation and the brake has reached its wear limit.

### Braking

The brake does not start generating braking torque immediately after the coil voltage is switched off. First the magnetic energy must decline to the point that the spring force can overcome the magnetic force. This occurs at the holding current  $I_{hold}$ , which is lower than the release current.

The response time depends on how the voltage is switched off.

Switching off the AC supply voltage to a type SG standard rectifier

- a) Rectifier powered from the motor terminal board (Figure 4, curve 1)  
Response time  $t_{A1}$ : very long

Cause: Due to the residual magnetism of the motor, after the motor voltage is switched off a slowly decaying voltage is induced, and it continues to supply power to the rectifier and thereby to the brake. In addition, the magnetic energy of the brake coil is dissipated relatively slowly in the freewheel circuit of the rectifier.

- b) Rectifier powered separately (Figure 4, curve 2)  
Response time  $t_{A2}$ : long

Cause: After the rectifier voltage is switched off, the magnetic energy of the brake coil is dissipated relatively slowly in the freewheel circuit of the rectifier.

If the supply voltage is interrupted on the AC side, no significant switch-off voltage occurs on the electromagnet coil.

### Interrupting the DC circuit of the electromagnet coil (Figure 4, curve 3)

a) By a mechanical switch

- with separate power supply from a DC control voltage mains or
- at the DC switch contacts (A2 and A3) of the type SG standard rectifier

Response time  $t_{A3}$ : very short

Cause: The magnetic energy of the brake coil is dissipated very quickly by arcing across the switch contacts.

b) Electronic

Using a type ESG or MSG special rectifier

Response time  $t_{A3}$ : short

Cause: The magnetic energy of the brake coil is dissipated quickly by a varistor integrated in the rectifier.

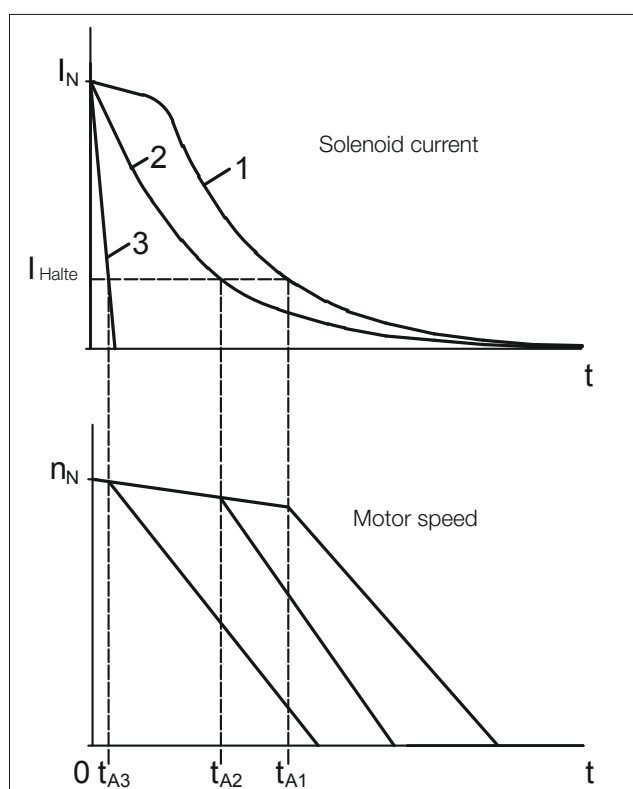

Figure 3: Idealised coil current and motor speed curves after switching off power on the AC side (1 and 2) or DC side (3)

If the circuit is interrupted on the DC side, a high voltage  $u_q$  is induced by the electromagnet coil. The magnitude of this voltage depends on the inductance  $L$  of the coil and the switch-off speed  $di/dt$  according to the formula

$$u_q = L \cdot \frac{di}{dt}$$

Due to the winding design, the inductance  $L$  increases with increasing rated coil voltage. Consequently, the voltage spikes induced at switch-off can reach hazardous levels with relatively high coil voltages. For this reason, a varistor is included in the circuit for all brakes with voltages greater than 24 V.

This varistor is solely intended to protect the electromagnet coil; it is not intended to protect adjacent electronic components or devices against electromagnetic interference. On request, brakes with rated voltages of 24 V or less can also be fitted with a varistor.

If the circuit is interrupted on the DC side by a mechanical switch, the resulting arcing over the switch contacts causes strong erosion of the contacts. For this reason, only special DC contactors or adapted AC contactors with contacts rated for use class AC3 as specified in EN 60947-4-1 may be used.



### Specifications of holding brakes with emergency stop capability

The maximum allowable friction energy values stated here do not apply to brake motors for use in areas with potentially explosive atmospheres.

Refer to separate data in appropriate documents for explosion-proof drives.

Type	M <sub>Br</sub> [Nm]	W <sub>max</sub> [10 <sup>3</sup> J]	W <sub>th</sub> [10 <sup>3</sup> J]	W <sub>L</sub> [10 <sup>6</sup> J]	t <sub>A</sub> [ms]	t <sub>AC</sub> [ms]	t <sub>DC</sub> [ms]	P <sub>el</sub> [W]	J [10 <sup>-3</sup> kgm <sup>2</sup> ]
E003B9	3	1.5	-	-	35	150	15	20	0.01
E003B7	2.2	1.8	-	-	28	210	20		
E003B4	1.5	2.1	-	-	21	275	30		
E004B9	5	2.5	-	-	37	125	15	30	0.017
E004B8	4	3	-	-	30	160	18		
E004B6	2.8	3.6	-	-	23	230	26		
E004B4	2	4.1	-	-	18	290	37		
E004B2	1.4	4.8	-	-	15	340	47		
ES/EH010AX	15*	3	-	-	110	-	30	35	0.045
ES/EH010A9	10	3	-	-	60	100	15		
ES/EH010A8	8	3	-	-	55	150	20		
ES/EH010A5	5	3	-	-	45	220	20		
ES/EH010A4	4	3	-	-	30	250	20		
ES/EH010A2	2.5	3	-	-	25	350	25		
ES027AX	32*	2.5	-	-	80	-	30	50	0.172
ES/EH027A9	27	2.5	-	-	120	100	15		
ES/EH027A7	20	2.5	-	-	100	130	20		
ES/EH027A6	16	2.5	-	-	80	170	25		
ES/EH040A9	40	3.5	-	-	100	100	20	65	0.45
ES/EH040A8	34	3.5	-	-	80	200	25		
ES/EH040A7	27	3.5	-	-	70	250	30		
ES/EH070AX	90*	3.5	-	-	120	-	40	85	0.86
ES/EH070A9	70	3.5	-	-	120	150	18		
ES/EH070A8	63	3.5	-	-	120	200	20		
ES/EH070A7	50	3.5	-	-	90	220	25		
ES/EH125A9	125	4.5	-	-	170	220	25	105	1.22
ES/EH125A8	105	4.5	-	-	150	320	28		
ES/EH125A7	85	4.5	-	-	135	350	30		
ES/EH125A6	70	4.5	-	-	120	440	35		
ES125A5	57	4.5	-	-	100	600	40		
ES125A3	42	4.5	-	-	90	700	45		
ES/EH200A9**	200	8	-	-	400	150	22	105	2.85
ES/EH200A8**	150	8	-	-	280	250	35		
ES/EH200A7**	140	8	-	-	200	320	35		
ES250A9**	250	9	-	-	300	500	45	135	6.65
ES250A8**	200	9	-	-	200	960	60		
ES250A6**	150	9	-	-	160	1100	60		
ES250A5**	125	9	-	-	150	1500	90		
ES250A4**	105	9	-	-	130	1800	110		
ZS300A9**	300	8	-	-	280	220	35	75	5.7
ZS300A8**	250	8	-	-	210	380	45		
EH400A9**	400	10	-	-	300	600	60	180	19.5
EH400A7**	300	10	-	-	200	850	75		
EH400A5**	200	10	-	-	150	1400	85		
ZS500A9**	500	9	-	-	320	320	50	100	13.3
ZS500A8**	400	9	-	-	260	600	60		

\* Requires overexcitation; permissible only with MSG rectifier

\*\* Cannot be combined with PMSM motors of the S series

Braking torque tolerance: -10 / +30 %

W<sub>th</sub> and W<sub>L</sub> are not specified because little or no braking energy is dissipated by holding brakes when they are used as intended.

For versions with braking torque marked with \*, which may only be used with an MSG rectifier, the values of t<sub>A</sub> and t<sub>DC</sub> apply to operation with an MSG rectifier; i.e. t<sub>A</sub> for overexcitation or t<sub>DC</sub> for electronic circuit interruption on the DC side.

Due to the effects of operating temperature and manufacturing tolerances, actual response times may differ from the guideline values listed here.

# Motor Mounted Components

## Brake

### Specifications of working brakes

The maximum braking energy values stated here do not apply to brake motors for use in areas with potentially explosive atmospheres.

Refer to separate data in appropriate documents for explosion-proof drives.

Type	M <sub>Br</sub> [Nm]	W <sub>max</sub> [10 <sup>3</sup> J]	W <sub>th</sub> [10 <sup>3</sup> J]	W <sub>L</sub> [10 <sup>6</sup> J]		t <sub>A</sub> [ms]	t <sub>AC</sub> [ms]	t <sub>DC</sub> [ms]	P <sub>el</sub> [W]	J [10 <sup>-3</sup> kgm <sup>2</sup> ]
				without HL***	with HL***					
E003B9	3	1.5	36	55	55	35	150	15	20	0.01
E003B7	2.2	1.8	36	90	90	28	210	20		
E003B4	1.5	2.1	36	140	140	21	275	30		
E004B9	5	2.5	60	50	50	37	125	15	30	0.017
E004B8	4	3	60	100	100	30	160	18		
E004B6	2.8	3.6	60	180	180	23	230	26		
E004B4	2	4.1	60	235	235	18	290	37		
E004B2	1.4	4.8	60	310	310	15	340	47		
ESX/EHX010AX	15*	3	250	120	120	110	-	30		
ESX/EHX010A9	10	3	250	120	120	60	100	15	35	0.045
ESX/EHX010A8	8	3	250	150	150	55	150	20		
ESX/EHX010A5	5	3	250	240	240	45	220	20		
ESX/EHX010A4	4	3	250	300	240	30	250	20		
ESX/EHX010A2	2.5	3	250	390	240	25	350	25		
ESX027AX	27*	10	350	150	150	80	-	30		
ESX/EHX027A9	22	10	350	150	150	120	100	15	50	0.172
ESX/EHX027A7	16	10	350	300	300	100	130	20		
ESX/EHX027A6	13	10	350	350	350	80	170	25		
ESX/EHX040A9	32	20	450	420	420	100	100	20		
ESX/EHX040A8	27	20	450	560	490	80	200	25	65	0.45
ESX/EHX040A7	22	20	450	700	490	70	250	30		
ESX/EHX070AX	72*	28	550	700	700	120	-	40	85	0.86
ESX/EHX070A9	58	28	550	500	500	120	150	18		
ESX/EHX070A8	50	28	550	800	700	120	200	20		
ESX/EHX070A7	40	28	550	1200	700	90	220	25		
ESX/EHX125AX	100*	40	700	1900	1900	100	-	70	105	1.22
ESX/EHX125A9	85	40	700	1700	1700	150	320	28		
ESX/EHX125A8	70	40	700	1900	1700	135	350	30		
ESX/EHX125A7	58	40	700	2700	1700	120	440	35		
ESX125A5	45	40	700	3300	1700	100	600	40		
ESX125A3	34	40	700	3300	1700	90	700	45		
ESX/EHX200AX**	160*	60	850	2000	2000	105	-	70	105	2.85
ESX/EHX200A9**	120	60	850	1700	1700	280	250	35		
ESX/EHX200A8**	110	60	850	2600	2600	200	320	35		
ESX250A9**	200	84	1000	2800	2800	300	500	45	135	6.65
ESX250A8**	160	84	1000	6800	5700	200	960	60		
ESX250A6**	120	84	1000	8500	5700	160	1100	60		
ESX250A5**	100	84	1000	11000	5700	150	1500	90		
ESX250A4**	85	84	1000	11000	5700	130	1800	110		
ZSX300A9**	250	60	850	1300	1300	280	220	35	75	5.7
ZSX300A8**	200	60	850	2000	2000	210	380	45		
EHX400A9**	320	120	1100	3000	3000	300	600	60	180	19.5
EHX400A7**	240	120	1100	4800	4800	200	850	75		
EHX400A5**	160	120	1100	6000	4800	150	1400	85		
ZSX500A9**	400	84	1000	2800	2800	320	320	50	100	13.3
ZSX500A8**	320	84	1000	4000	4000	260	600	60		

\* Requires overexcitation; permissible only with MSG rectifier

\*\* Cannot be combined with PMSM motors of the S series

\*\*\* HL = manual release

Braking torque tolerance:

E003 / E004: -10 / +30 %

ESXxx / ZSXxx: -20 / +30 % after run-in; up to -30 % in new condition.

For versions with braking torque marked with \*, which may only be used with an MSG rectifier, the values of t<sub>A</sub> and t<sub>DC</sub> apply for operation with an MSG rectifier; i.e. t<sub>A</sub> for overexcitation or t<sub>DC</sub> for electronic circuit interruption on the DC side.

The values for W<sub>L</sub> are guidelines; actual values may vary significantly depending on the application situation. Periodic inspection of the air gap or brake disc thickness is recommended.

Actual response times may differ from the times listed here due to the effects of operating temperature, brake disc wear and manufacturing tolerances.

### Key to symbols

$M_{Br}$	Rated braking torque
$W_{max}$	Maximum allowable friction energy for an emergency stop with a holding brake
$W_{max}$	Maximum allowable friction energy for each brake cycle with working brakes
$W_{th}$	Maximum allowable braking energy per hour
$W_L$	Maximum allowable braking energy until maintenance; i.e. brake disc replacement or air gap adjustment. Air gap adjustment is possible only with type ZSxxx brakes.
HL	Manual release
$t_A$	Response time for release with normal excitation. Overexcitation with a type MSG special rectifier reduces the response time by approximately 50 %.
$t_{AC}$	Response time for brakes with AC-side switch-off, i.e. by switching off the supply voltage to a separately powered standard rectifier. If the supply voltage for the rectifier is taken from the motor terminals, considerably longer response times should be expected (depending on the motor size and winding design).
$t_{DC}$	Response time for braking with DC-side circuit interruption by a mechanical switch. In the case of electronic circuit interruption on the DC side by a type ESG or MSG special rectifier, the response times will be approximately two to three times as long.
$P_{el}$	Electromagnet coil power consumption at 20 °C. Depending on the rated voltage of the coil, the actual power may differ from the guideline value stated here.
J	Moment of inertia of the drive bush and brake disc(s)

# Motor Mounted Components

## Brake

### Connection

The electrical connections to the brake are made in the motor terminal box using terminals or the rectifier. Standard voltages:

380–420 V 50/60 Hz (brake coil voltage 180 V DC)

220–230 V 50/60 Hz (brake coil voltage 105 V DC)

24 V DC (brake coil voltage 24 V DC)

Other voltages are available at additional cost.

### DC connection via terminals (K)

The brake must be connected via separate terminals in the motor or brake terminal box directly to the DC voltage. The standard voltages are 180 V DC, 105 V DC and 24 V DC. Brakes with other operating voltages are available at additional cost.

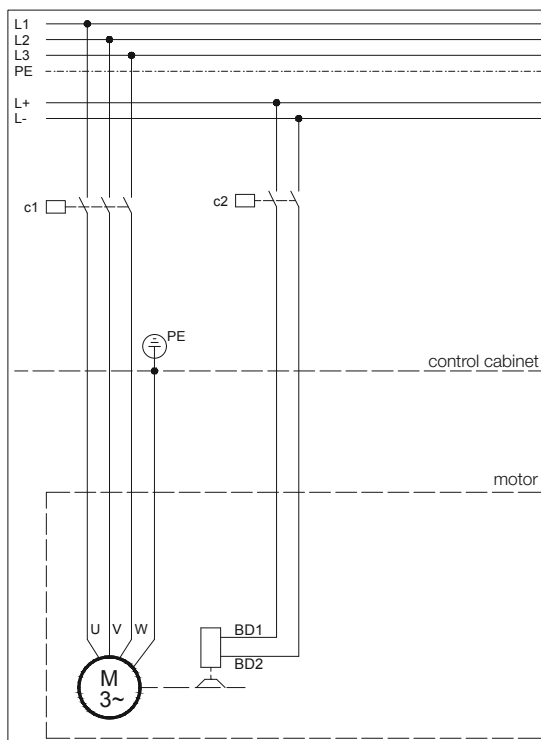

### Standard rectifier (S)

Working principle	Half-wave rectifier with switch contacts for DC-side circuit interruption
Input voltage $U_1$	max. 575 VAC +5 %
Output voltage	$0.45 \times U_1$ VDC
Max. output current	2.5 A DC
Ambient temperature	-40 to +40 °C
Connection	Caged Clamp terminals with clamp lever
Clampable conductor cross-section	max. 1.5 mm <sup>2</sup> without wire end sleeve max. 1.5 mm <sup>2</sup> with wire end sleeve
Approvals	c-CSA-us c-UL-us (only in combination with B2000 geared motors and brakes in the ES(X) or ZS(X) product series)

The brake must be connected to the AC supply via the standard rectifier in the motor terminal box or brake terminal box. The standard voltages are 380 ... 420 V 50/60 Hz or 220 ... 230 V 50/60 Hz. Other voltages up to 575 V are available at extra cost. In a configuration with standard rectifier, the brake circuit can be interrupted by an extra contact on the d.c. side in order to reduce the response time. This significantly reduces the braking time and overtravel distance.

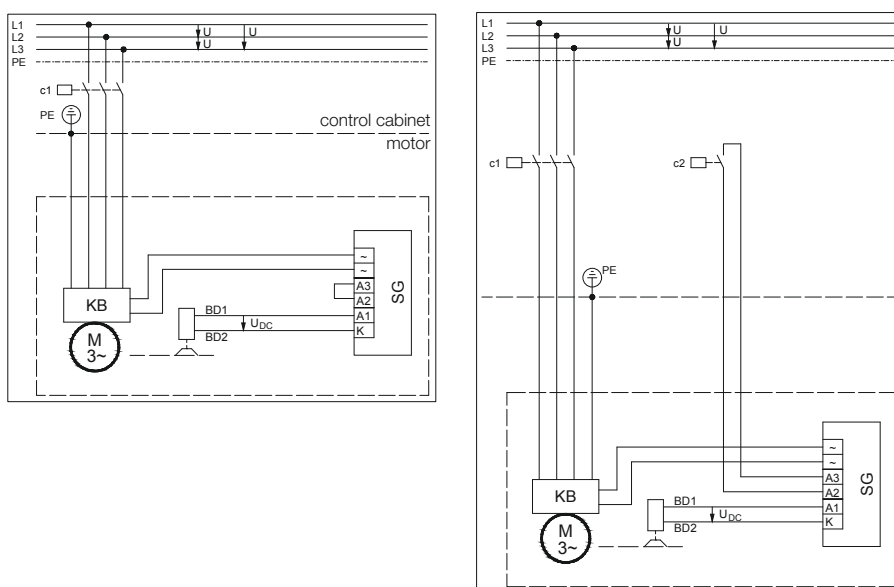

Voltage connection for the rectifier from the motor terminal block or cage clamp (see Rectifier Connection on Motor Terminal Block or Cage Clamp)

# Motor Mounted Components

## Brake

### Rectifier for electronic rapid shutdown (E)

Working principle	Half-wave rectifier with electronic DC-side circuit interruption
Input voltage $U_1$	220–460 V AC $\pm 5\%$ , 50/60 Hz
Output voltage	$0.45 \times U_1$ V DC
Max. output current	1 A DC
Ambient temperature	-20 °C to +40 °C
Clampable conductor cross-section	max. 1.5 mm <sup>2</sup>

This rectifier permits electronic DC-side interruption of the brake circuit. No additional cable to the rectifier is necessary. The rectifier is supplied complete with a protective resistor which prevents a mains short-circuit via the shutdown arc of the high-speed motor contactor. Brake response times are significantly shorter than those achievable by AC-side interruption of the brake circuit. They are, however, longer than those achievable with DC-side interruption by a mechanical switch. The brake must be connected to the alternating current via the rapid shutdown rectifier in the motor terminal box or the brake terminal box. The standard voltages are 380 ... 420 V 50/60 Hz or 220 ... 230 V 50/60 Hz. Other voltages up to 460 V are available at extra cost.

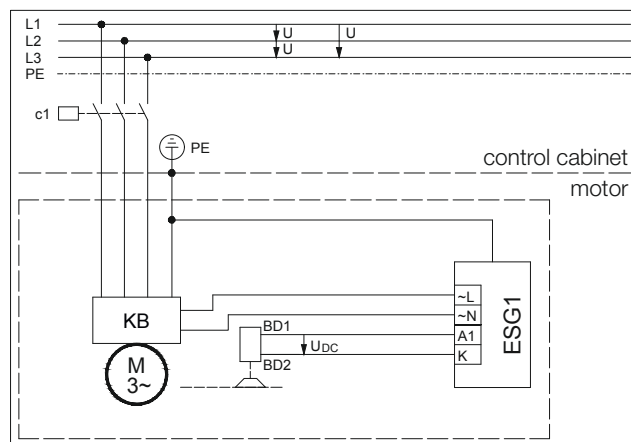

Voltage connection for the rectifier from the motor terminal block or cage clamp (see Rectifier Connection on Motor Terminal Block or Cage Clamp)

### Rectifier for overexcitation and rapid shutdown (M)

Working principle	MSG 1.5.480I Half-wave rectifier with time-limited overexcitation and electronic DC-side circuit interruption Fast shutdown due to no motor current in one phase
Input voltage $U_1$	220–480 V AC +6 / -10 %, 50/60 Hz
Output voltage	0.9 x $U_1$ V DC during overexcitation 0.45 x $U_1$ V DC over overexcitation period
Overexcitation time	0.3 s
Max. output current	1.5 A DC
Ambient temperature	-20 °C to +40 °C
Clampable	
conductor cross-section	max. 1.5 mm <sup>2</sup>
Working principle	MSG 1.5.500U Half-wave rectifier with time-limited overexcitation and electronic DC-side circuit interruption Fast shutdown due to the absence of input voltage
Input voltage $U_1$	220–500 V AC ±10 %, 50/60 Hz
Output voltage	0.9 x $U_1$ V DC during overexcitation 0.45 x $U_1$ V DC over overexcitation period
Overexcitation time	0.3 s
Max. output current	1.5 A DC
Ambient temperature	-20 °C to +40 °C
Clampable	
conductor cross-section	max. 1.5 mm <sup>2</sup>

In cases where there are high motor switching frequencies, the brake can be de-energised more rapidly with this rectifier thereby significantly reducing the thermal stress on the motor. In addition, interrupting the brake's DC circuit by electronic means significantly reduces response times. Depending on the circumstances in which they are to be used, either the MSG 1.5.500 U (rapid shutdown brought about by removed supply voltage) or MSG 1.5.480 I (rapid shutdown brought about by removed motor current in a phase) is used. Power supply 220 to 480 V AC.

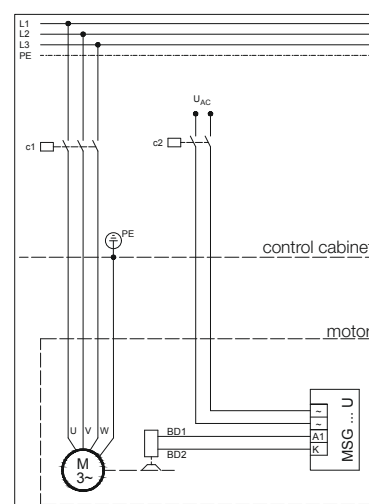
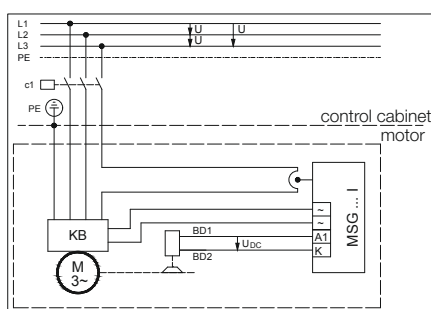

Rectifier Connection on Motor Terminal Block or Cage Clamp

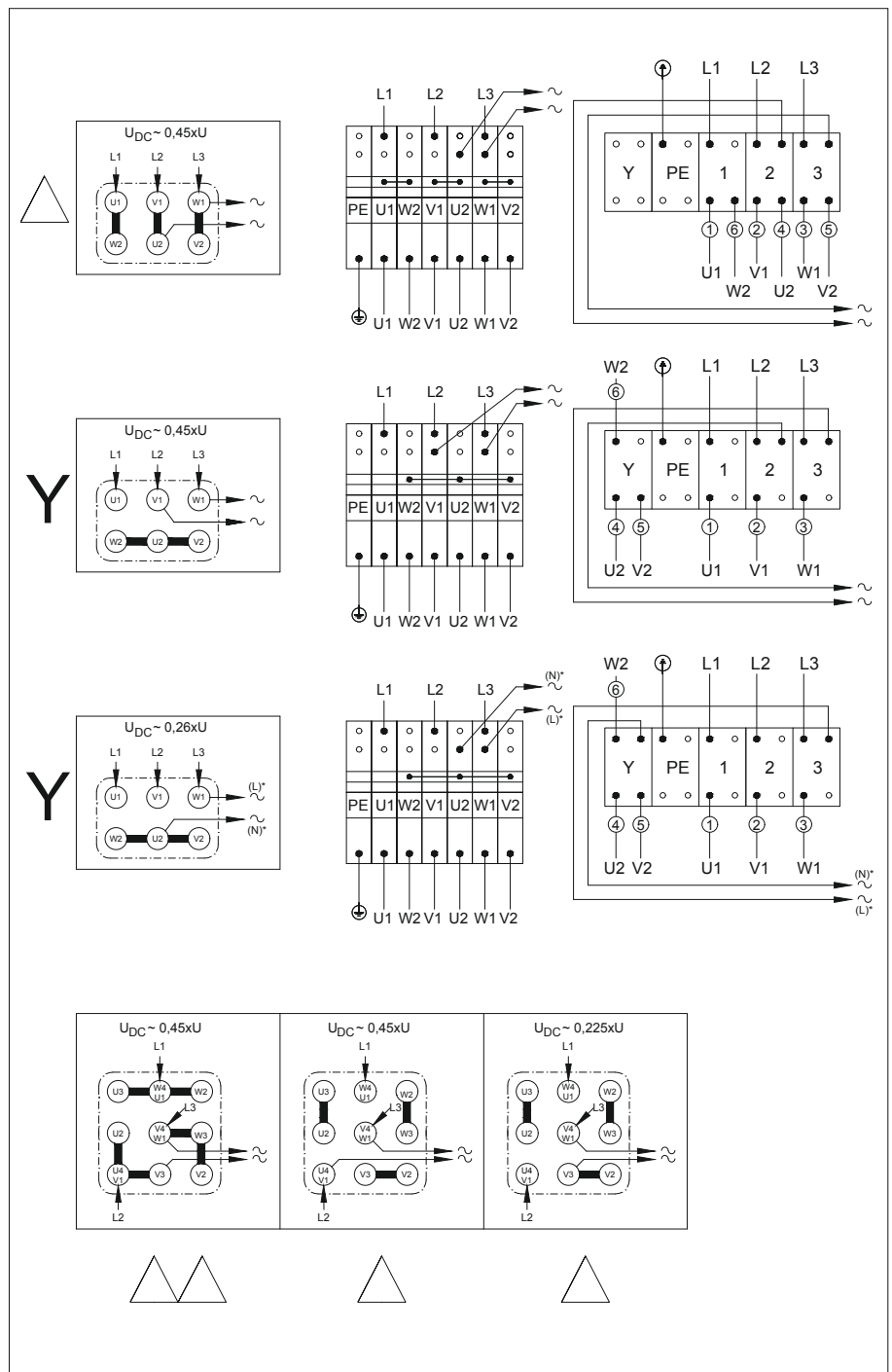



**Brake connection, operation with frequency converter**

The voltage present at the motor terminal block when operating with a frequency converter is frequency-dependent. Brakes require a constant voltage, so they need a separate electrical connection. This is the reason why the brake is not connected to the motor terminals ex-works.

**Brake connection, pole-changing motors**

The brakes of pole-changing motors need a separate electrical connection. As is the case with motors for operation with frequency inverters, the brake is not connected to the motor terminals ex-works.

**Manual release (HA, HN)**

All brakes are available with mechanical manual release on request. Non-latching manual release is the standard version (HN). A latching manual release (HA) can be supplied if required for all brake sizes.

**Explosion protection**

Brakes for use in hazardous areas are subject to special regulations. Please consult our support specialists in these special cases.

**Back stop (RR, RL)**

Motors of size D..08.. to D..11.. are available with backstop. The locking rotational direction clockwise (RR) or anticlockwise (RL) is to given in the order. The reference is the connection side of the gearbox. Should the connection side not be clearly defined, gearbox side "V" (front) will be assumed (see chapter 10 Dimensions drawing "Motor with back stop").

Note that the back-stop functionality on a motor operating with a frequency converter is guaranteed only at rotor speeds above 740/min.

It is advisable to consult BAUER for applications in corrosive atmospheres, especially for motor-down installed positions.

# Motor Mounted Components

## Brake

**Second motor shaft extension (ZW, ZV)** The motors are also available on request with a second motor shaft extension in design ZW (shaft with key) or ZV (shaft with square end).

Half the central motor's rated power is available at each of the two shafts. Permissible radial loads available on request. Guards are not included in the scope of supply (for dimensional drawing see chapter Motor Mounted Components - Dimensions).

Motors with brakes are available on request with a second shaft stub extended through the brake.

### Protective fan cowl (D)

A protective hood over the fan cowl is recommended for outdoor installations where the motor is pointing upward and subject to severe or prolonged exposure to water (dimensional drawing, see chapter Motor Mounted Components - Dimensions).

This protective hood is mandatory for upright explosion-proof motors.

A special fan cowl for the textiles industry is available on request at extra cost. This design prevents airborne fibres and fluff clogging the fan cowl.

### Motor-independent fan (FV)

For special applications, standard motors and brake motors of size D..08.. and larger are available with externally mounted motor-independent fans. The standard line voltage of the motor-independent fan matches the voltage of the geared motor (dimensional drawing for motor-independent fan, see chapter Motor Mounted Components - Dimensions).

The independent fans are supplied as standard with Bayonet-fitting for standard motors size D..11.. .

#### Technical Data:

Multivolt Conception Running capacitor for single phase duty enclosed as standard.

#### Technical Data Motor-independent fan

Mode	Frame size	Blower Diameter [mm]	Range of voltage		max. permissible current		max. power input	
			[V]		[A]		[W]	
			50 Hz	60 Hz	50 Hz	60 Hz	50 Hz	60 Hz
1 ~ Δ (Δ)	63	118	230-277	230-277	0.18	0.21	46	54
	71	132	230-277	230-277	0.18	0.21	48	56
	80	150	230-277	230-277	0.19	0.22	48	59
	90	169	220-277	220-277	0.29	0.23	59	61
	100	187	220-277	220-277	0.29	0.28	62	73
	112	210	220-277	220-277	0.27	0.36	64	88
	132	250	230-277	230-277	0.52	0.61	125	163
	160-200	300	230-277	230-277	1.05	1.52	246	390
3 ~ Y	63	118	346-525	380-575	0.09	0.08	28	29
	71	132	346-525	380-575	0.09	0.07	29	28
	80	150	346-525	380-575	0.09	0.07	33	36
	90	169	346-525	380-575	0.22	0.18	78	71
	100	187	346-525	380-575	0.21	0.18	80	80
	112	210	346-525	380-575	0.2	0.17	87	93
	132	250	346-525	380-575	0.37	0.32	160	180
	160-200	300	346-525	380-575	0.74	0.62	314	391
3 ~ Δ	63	118	200-303	220-332	0.15	0.14	28	29
	71	132	200-303	220-332	0.15	0.13	29	28
	80	150	200-303	220-332	0.16	0.13	33	36
	90	169	200-303	220-332	0.39	0.32	78	71
	100	187	200-303	220-332	0.37	0.3	80	80
	112	210	200-303	220-332	0.35	0.29	87	93
	132	250	200-303	220-332	0.64	0.55	160	180
	160-200	300	200-303	220-332	1.28	1.08	314	391

### Shaft encoder (G)

Bauer gear motors can be fitted with either an incremental encoder or an absolute encoder for special applications. Both the standard incremental encoder and the absolute encoder are optimised and suitable for use with all modern inverters.

Bauer standard encoders as from motor frame size D..05.. (0,18 kW) are protected against mechanical damage by means of a protective cover (Additional Dimension Sheet see Motor Mounted Components - Dimensions).

Special features: standard incremental encoder:

- Robust mount
- EMC-tested
- Protected against polarity reversal
- Supply voltage 8-30 V DC
- A-, B- and N-lines and inverted signals or output signals as preferred
- HTL output circuit (TTL on request)
- 1024 pulses per revolution

Special features: standard absolute encoder

- Steps per revolution: 8192 (13 Bit)
- Number of turns: 4096 (12 Bit) shaft turns
- Execution of electronic: SSI (Synchronous-Serial Interface)
- Output code: Gray-Code
- Supply voltage: 11-27 V DC
- Loss efficiency (no load):  $\leq 3$  Watt
- Output driver: RS-422 (2-wire)

# Motor Mounted Components

## Incremental rotary encoder

### Functional description

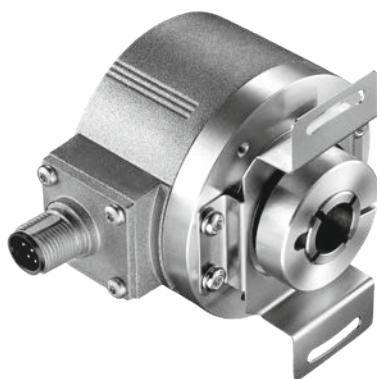

Incremental encoders are used to determine motor shaft positions. An incremental encoder detects rotary motion and converts it into an electrical output signal. An encoder disc with a specific number of periods per rotation senses angular motion. The optoelectronic scanning unit generates signals and issues pulses after the signals have been processed in trigger stages. The resolution is defined by the number of opaque and clear segments on the encoder disc. For example, an encoder with 1024 lines will generate a sequence of 1024 pulses for one full rotation.

The combination of an incremental encoder and a frequency converter allows optimised solutions to be developed, such as

- speed controllers with a wide adjustment range
- accurate speed control
- constant-speed control
- position control

Supply voltage:	8–30 V DC with HTL 5 V DC with differential TTL
Output signals:	HTL A, B and N tracks; optional TTL
Pulses per revolution:	1024 Optional 1...65536
Enclosure rating:	IP65 (optional IP67)
Temperature range:	-40 °C to +100 °C

### Electrical specifications

Output voltage	RS 422 (TTL compatible)	RS 422 (TTL compatible)	Differential	Differential (7272)
Supply voltage	5–30 V DC	5 V ±5%	8–30 V DC	5–30 V DC
No-load current consumption With inversion:	max. 70 mA	max. 70 mA	max. 70 mA	max. 70 mA
Allowable load per channel: Pulse rate:	max. ±20 mA max. 300 kHz	max. ±20 mA max. 300 kHz	max. ±20 mA max. 160 kHz	max. ±20 mA max. 160 kHz
High signal level:	min. 2.5 V	min. 2.5 V	min. $U_B - 3$ V	min. $U_B - 3$ V
Low signal level:	max. 0.5 V	max. 0.5 V	max. 1 V	max. 1 V

### Plug end view with male pin insert

Connector type	8-pin M12 plug	12-pin M23 plug	MIL connector 10-pin
Layout			
Order code:	8.5000.XXX3.XXXX 8.5000.XXX4.XXXX	8.5000.XXX7.XXXX 8.5000.XXX8.XXXX	8.5000XXX.Y.XXXX
Mating 05.CMB-8181-0 connector:		8.0000.5012.0000	8.0000.5062.0000

### Signal assignments

Signal:	0 V GND	+U <sub>B</sub>	0 V Sens	+U <sub>B</sub> Sens	A	A	B	B	Z	Z	Shield
M23 Multifast, 12-pin connector; pin assignments:	10	12	11	2	5	6	8	1	3	4	1)
M12 Eurofast, 8-pin connector; pin assignments:	1	2			3	4	5	6	7	8	1)
Military version; 10-pin connector; pin assignments:	F	D		E	A	G	B	H	C	I	J <sup>1)</sup>
Cable; lead colour:	WH	BN	GY PK	RD BU	GN	YE	GY	PK	BU	RD	Shield

<sup>1</sup> Shield connected to plug housing.

Insulate unused outputs before putting into service.

# Motor Mounted Components

## Incremental rotary encoder

### Functional description

Absolute encoders detect both angular and rotational motions and convert them into electrical signals. In contrast to incremental encoders, with absolute encoders the current position is directly available. If an absolute encoder is moved mechanically while it is switched off, after the power is switched on again the current position can be read out immediately and directly. Absolute encoders are available in single-turn and multi-turn versions.

### Profibus DP interface

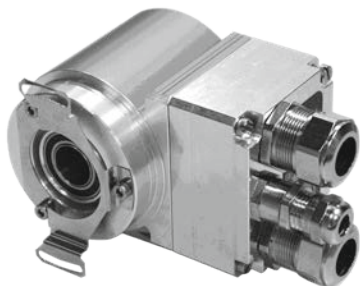

### Specifications

Supply voltage	11–27 VDC
No-load current consumption	< 350 mA
Total resolution <sup>1</sup>	≤ 33 bits
Number of steps per revolution, standard/extended <sup>1</sup>	≤ 8,192 / ≤ 32,768
Number of turns, standard/extended <sup>1</sup>	≤ 4,096 / ≤ 256,000
Profibus DP V0	IEC 61158, IEC 61784
PNO encoder profile	Class 1/Class 2
parameters <sup>1</sup>	Counting direction switchover, scaling function, etc.
Output code <sup>1</sup>	Binary, Gray, truncated Gray
Address	3–99, set using a rotary switch
Baud rate	9.6 kbit/s to 12 Mbit/s
TR-specific functions <sup>1</sup>	Gear and speed outputs
Data width on bus for actual position	≤ 25 bits
Permissible mechanical speed	≤ 12,000 rpm
Shaft load	Own mass
Bearing life	≥ 3.9 × 10 <sup>10</sup> revolutions at
- speed	≤ 6,000 rpm
- operating temperature	≤ 60 °C
Shaft diameter [mm]	10H7
Permissible angular acceleration	≤ 10 <sup>4</sup> rad/s <sup>2</sup>
Moment of inertia	2.5 × 10 <sup>-6</sup> kg m <sup>2</sup> (typical)
Start-up torque at 20 °C	2 Ncm (typical)
Weight	0.3–0.5 kg

<sup>1</sup>) Configurable parameter

### Ambient conditions

Vibration (EN 60068-2-6:1996)	≤ 100 m/s <sup>2</sup> , sinusoidal 50–2,000 Hz
Shock (EN 60068-2-27:1995)	≤ 1000 m/s <sup>2</sup> , half-cycle sinusoidal 11 ms
EMC	- Interference emission compliant with EN 61000-6-3:2007 - Interference immunity compliant with EN 61000-6-2:2006
Operating temperature	0 °C to +60 °C; optionally -20 °C to +70 °C
Storage temperature	-30 °C to +80 °C, dry
Relative humidity (EN 60068-3-4:2002)	98 %, non condensing
Enclosure rating (EN 60529:1991) <sup>2</sup>	IP65

<sup>2</sup> With mating connector fitted and/or cable glands fitted and tightened

# Motor Mounted Components

## Absolute rotary encoders

### SSI interface

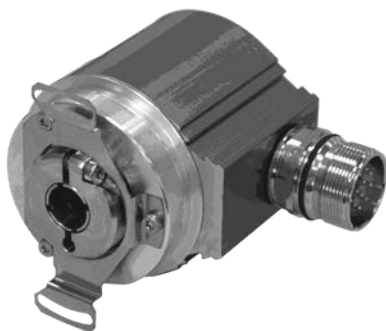

### Specifications

Supply voltage	11–27 V DC
No-load current consumption	< 350 mA
Total resolution <sup>1</sup>	≤ 25 bits
Number of steps per revolution <sup>1</sup>	≤ 8,192
Number of rotations, standard <sup>1</sup>	≤ 4,096
Number of rotations, extended <sup>1</sup>	≤ 256,000
SSI	Synchronous Serial Interface
Clock input	Optocoupler
Data output	RS-422, 2-wire
Clock frequency	80 kHz – 1 MHz
Monostable time $t_m$	$16 \mu s \leq t_m \leq 25 \mu s$ (20 $\mu s$ typical)
Output code <sup>1</sup>	Binary, Gray, BCD
Output format <sup>1</sup>	Standard, Tannenbaum, SSI + CRC, 26-bit cycle, variable number of data bits
Negative values <sup>1</sup>	Sign and magnitude, twos complement
SSI or parallel special bits <sup>1</sup>	Limit switch, overspeed, direction indication, motion indication, error indication, parity
F/R <sup>1</sup>	Counting direction
Preset <sup>1</sup>	Electronic alignment
Logic levels	“0” < +2 VDC; “1” = supply voltage
Permissible mechanical speed	≤ 12,000 rpm
Shaft load	Own mass
Bearing life	≥ $3.9 \times 10^{10}$ revolutions at
- speed	≤ 6,000 rpm
- operating temperature	≤ 60 °C
Shaft diameter [mm]	10H7
Permissible angular acceleration	≤ $10^4$ rad/s <sup>2</sup>
Moment of inertia	$2.5 \times 10^{-6}$ kg m <sup>2</sup> (typical)
Start-up torque at 20 °C	2 Ncm (typical)
Weight	0.3–0.5 kg
Optional	- incremental signals, RS422 levels K1+, K1-, K2+, K2- with 1024 or 2048 pulses

<sup>1)</sup> Configurable parameter

### Ambient conditions

Vibration (EN 60068-2-6:1996)	≤ 100 m/s <sup>2</sup> , sinusoidal 50–2,000 Hz
Shock (EN 60068-2-27:1995)	≤ 1000 m/s <sup>2</sup> , half-cycle sinusoidal 11 ms
EMC	
- Interference emission compliant with EN 61000-6-3:2007	
- Interference immunity compliant with EN 61000-6-2:2006	
Operating temperature	0 °C to +60 °C; optionally -20 °C to +70 °C
Storage temperature	-30 °C to +80 °C, dry
Relative humidity (EN 60068-3-4:2002)	98 %, non condensing
Enclosure rating (EN 60529:1991) <sup>2)</sup>	IP65

<sup>2)</sup> With mating connector fitted and/or cable glands fitted and tightened

In addition to the angular position within a rotation, multiturn encoders detect multiple rotations. An internal reduction gear mechanism connected to the motor shaft is used to detect the number of turns. Consequently, the value measured by a multiturn encoder consists of the current angular position and the number of turns. As with incremental encoders, the reading is calculated and output via various interface modules, depending on the interface.

On request, a large range of motor frames can be fitted with sensor bearings. The output signal from the sensor allows the direction of rotation to be determined, among other things. The number of possible pulse counts depends on the frame size. Please enquire for more information.

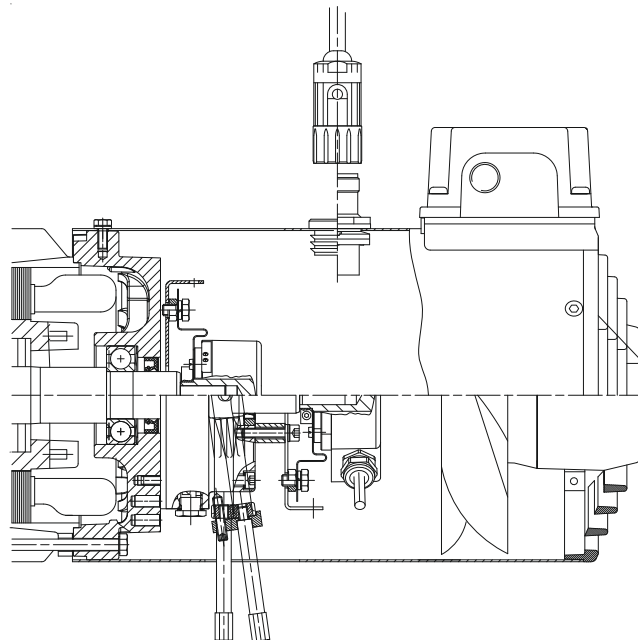
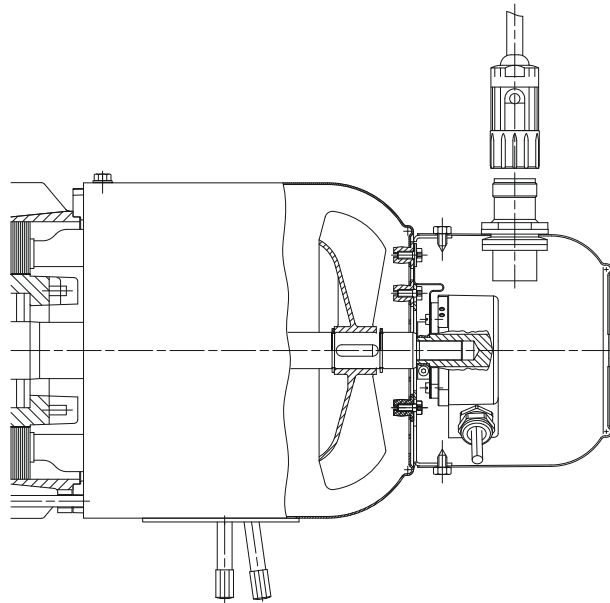
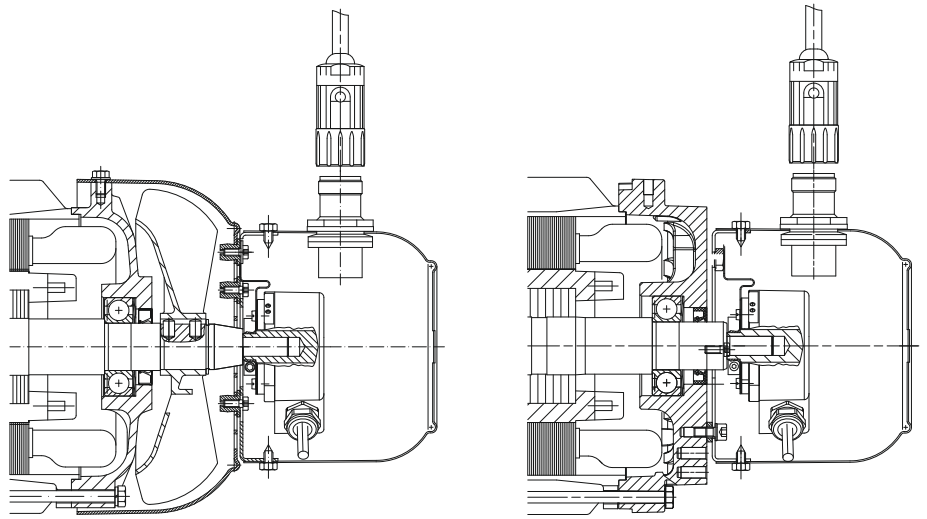

# Energy Efficient Geared Motors

## Electric overhead conveyors series BM

---



# Energy Efficient Geared Motors

## Electric overhead conveyors series BM

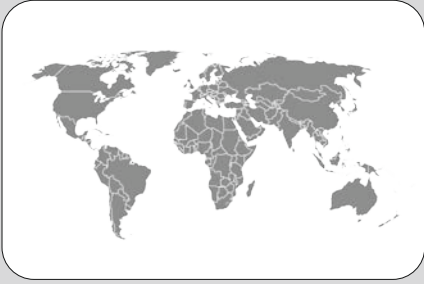

# 14

### BAUER global

North America.....	255
Latin America.....	256
Europe .....	257
Eastern Europe .....	260
Middle East & Africa.....	261
APAC.....	262
China.....	263

# Energy Efficient Geared Motors

## Electric overhead conveyors series BM

---

14

# Geared motors for electric overhead conveyors series BM

## North America



### North America



<b>Canada</b>	Bauer GMC	4020B Sladeview Crescent, Unit 5 L5L 6B1 Mississauga	<b>Phone</b>	+1 (905) 814 5152	
			<b>Fax</b>	+1 (905) 814 5153	<a href="http://www.bauergmc.com">www.bauergmc.com</a>
<b>United States</b>	Bauer Gear Motor LLC.	701 Carrier Drive NC 28216 Charlotte	<b>Phone</b>	+1 (800) 3870130	<a href="mailto:bauer.us@bauergears.com">bauer.us@bauergears.com</a>
			<b>Fax</b>	+1 (732) 4698773	<a href="http://www.bauergears.com">www.bauergears.com</a>

# Geared motors for electric overhead conveyors series BM

## Latin America



### Latin America



<b>Belize</b>	Transmisiones LTDA.	Cra. 69 B No. 21 A - 24 Parque Industrial Salitre 77158 Bogota / Colombia	<b>Phone</b> <b>Fax</b>	+57 (1) 4126898 +57 (1) 2929737	aguerrero@transmisiones.de http://www.transmisiones.de
<b>Bolivia</b>	Transmisiones LTDA.	Cra. 69 B No. 21 A - 24 Parque Industrial Salitre 77158 Bogota / Colombia	<b>Phone</b> <b>Fax</b>	+57 (1) 4126898 +57 (1) 2929737	aguerrero@transmisiones.de http://www.transmisiones.de
<b>Brazil</b>	MKN Acionamentos LTDA	Rua Marco Gagliano 264 Americanópolis 04412-120 São Paulo-SP	<b>Phone</b> <b>Fax</b>	+55 (11) 56215574 +55 (11) 56211406	mkn.aciona@terra.com.br
<b>Chile</b>	Jung y Cia LTDA	Huerfanos 757 Of 310 8320167 Santiago de Chile	<b>Phone</b>	+56 (2) 26383731	jung@jung.cl
<b>Colombia</b>	Transmisiones LTDA.	Cra. 69 B No. 21 A - 24 Parque Industrial Salitre 77158 Bogota	<b>Phone</b> <b>Fax</b>	+57 (1) 4126898 +57 (1) 2929737	aguerrero@transmisiones.de www.transmisiones.de
<b>Costa Rica</b>	Transmisiones LTDA.	Cra. 69 B No. 21 A - 24 Parque Industrial Salitre 77158 Bogota / Colombia	<b>Phone</b> <b>Fax</b>	+57 (1) 4126898 +57 (1) 2929737	aguerrero@transmisiones.de www.transmisiones.de
<b>Cuba</b>	Transmisiones LTDA.	Cra. 69 B No. 21 A - 24 Parque Industrial Salitre 77158 Bogota / Colombia	<b>Phone</b> <b>Fax</b>	+57 (1) 4126898 +57 (1) 2929737	aguerrero@transmisiones.de www.transmisiones.de
<b>French Guiana</b>	Transmisiones LTDA.	Cra. 69 B No. 21 A - 24 Parque Industrial Salitre 77158 Bogota / Colombia	<b>Phone</b> <b>Fax</b>	+57 (1) 4126898 +57 (1) 2929737	aguerrero@transmisiones.de www.transmisiones.de
<b>Guatemala</b>	Juan Niemann & Cia. Ltda.	Apartado Postal 290 C/Mariscal Cruz, C.A. Guatemala Ciudad, C.A.	<b>Phone</b> <b>Fax</b>	+502 (331) 5454 +502 (334) 7453	jcniemann@jcniemann.com www.jcniemann.com/motorreductores
<b>Guyana</b>	Transmisiones LTDA.	Cra. 69 B No. 21 A - 24 Parque Industrial Salitre 77158 Bogota / Colombia	<b>Phone</b> <b>Fax</b>	+57 (1) 4126898 +57 (1) 2929737	aguerrero@transmisiones.de www.transmisiones.de
<b>Honduras</b>	Transmisiones LTDA.	Cra. 69 B No. 21 A - 24 Parque Industrial Salitre 77158 Bogota / Colombia	<b>Phone</b> <b>Fax</b>	+57 (1) 4126898 +57 (1) 2929737	aguerrero@transmisiones.de www.transmisiones.de
<b>Mexico</b>	Opeasa-Zugastek	2 Poniente 3102A Col. Amor 72140 Puebla	<b>Phone</b>	+52 (222) 4036242	info@zugastek.com www.zugastek.com
<b>Nicaragua</b>	Transmisiones LTDA.	Cra. 69 B No. 21 A - 24 Parque Industrial Salitre 77158 Bogota / Colombia	<b>Phone</b> <b>Fax</b>	+57 (1) 4126898 +57 (1) 2929737	aguerrero@transmisiones.de www.transmisiones.de
<b>Panama</b>	Transmisiones LTDA.	Cra. 69 B No. 21 A - 24 Parque Industrial Salitre 77158 Bogota / Colombia	<b>Phone</b> <b>Fax</b>	+57 (1) 4126898 +57 (1) 2929737	aguerrero@transmisiones.de www.transmisiones.de
<b>Paraguay</b>	Transmisiones LTDA.	Cra. 69 B No. 21 A - 24 Parque Industrial Salitre 77158 Bogota / Colombia	<b>Phone</b> <b>Fax</b>	+57 (1) 4126898 +57 (1) 2929737	aguerrero@transmisiones.de www.transmisiones.de
<b>Peru</b>	Transmisiones & Servicios S.A.C.	Alcanfores 981. of 601. 18 Miraflores - Lima	<b>Phone</b> <b>Fax</b>	+51 (1) 242 0862 +51 (1) 242 086221	info@transmisiones.pe www.transmisiones.pe
<b>Uruguay</b>	Tradinter S.R.L	Pereira de la luz 1327 11300 Montevideo	<b>Phone</b> <b>Fax</b>	+598 (2) 6221130 +598 (2) 6284691	
<b>Venezuela</b>	EMOTEC S.A.	Calle Johann Schafer, Edif. FHT, Piso 1, Oficina 1, Urb. Buena Vista, Caracas-Venezuela Urb. Sabana Grande Caracas	<b>Phone</b> <b>Fax</b>	+58 (212) 2715261 +58 (212) 2711838	ventas@emotecsacom www.emotecsacom



### Europe



<b>Andora</b>	TEM S.L. Bauer Gear Center for Spain and Portugal	Transmisiones Electromecánicas, Pol. Industrial Les Comes Calle Italia 11 Nave 9 08700 Igualada (Barcelona) / Spain	<b>Phone</b> <b>Fax</b>	+34 (93) 8056021 +34 (93) 8056022	info@tem-sl.com www.tem-sl.com
<b>Austria</b>	ESKO Elektromaschinenbau GmbH	Ankerweg 8 8753 Fohnsdorf	<b>Phone</b> <b>Fax</b>	+43 (3573) 27570 +43 (3573) 27570-4	office@esko.at www.esko.at
<b>Austria</b>	Mangold Elektromaschinen GmbH	Holzriedstr. 33 6960 Wolfurt	<b>Phone</b> <b>Fax</b>	+43 (5574) 64072-0 +43 (5574) 64072-9	info@mangoldgmbh.at www.mangoldgmbh.at
<b>Austria</b>	BIS Chemserv GmbH	Bau 28 St. Peter-Str. 25 Postfach 750 4021 Linz	<b>Phone</b> <b>Fax</b>	+43 (732) 69172278 +43 (732) 69173322	service@chemserv.at www.chemserv.at
<b>Austria</b>	BIS Chemserv GmbH	Haiminger-Str. 1 84489 Burghausen / Germany	<b>Phone</b> <b>Fax</b>	+49 (867) 7977507 +49 (867) 7977510	www.chemserv.at
<b>Belgium</b>	Bauer Gear Motor Europe GmbH Branch Office Belgium	p/a Regus Pastoor Cooremansstraat 3 1702 Groot-Bijgaarden	<b>Phone</b>	+32 (0) 2 8937280	info.be@bauergears.com www.bauergears.com
<b>Belgium</b>	emr NV/SA	Kruisstraat 61 C 9930 Lievegem	<b>Phone</b> <b>Fax</b>	+32 (9) 2515956 +32 (9) 2515891	emr@nvemr.be www.nvemr.be
<b>Bosnien and Herzegovina</b>	Indas Industry Assistance d.o.o.	Heroja Pinkija 95 YU-21000 Novi Sad Serbia and Montenegro	<b>Phone</b> <b>Fax</b>	+381(21) 4804800 +381(21) 4804808	office@indas.rs http://www.indas.rs
<b>Bulgaria</b>	NASA - D Ltd.	kv. Mladost IV bl.602, vh.1 (In front of Business Park Sofia) 1715 Sofia	<b>Phone</b> <b>Fax</b>	+359 (2) 9755065 +359 (2) 9755067	office@nasa-d.com www.nasa-d.com
<b>Bulgaria</b>	NASA - D Ltd.	12, Bitolya str. 9002 Varna	<b>Phone</b> <b>Fax</b>	+359 (52) 605995 +359 (52) 600498	varna@nasa-d.com www.nasa-d.com
<b>Croatia</b>	TALER ING d.o.o.	Jelovška cesta 43A 4264 Bohinjka Bistrica / Slovenia	<b>Phone</b> <b>Fax</b>	+386 (4) 5747128 +386 (4) 5747129	info@taler-ing.si www.taler-ing.si
<b>Cyprus</b>	Drivetech e.p.e.	Chrysostomou Smyrnis 124 18345 Moschato / Greece	<b>Phone</b> <b>Fax</b>	+30 (210) 7233318 +30 (210) 7233357	info@drivetech.gr www.drivetech.gr
<b>Czech Republic</b>	Jan Komárek-HMF	Sturova 15 415 02 Teplice	<b>Phone</b> <b>Fax</b>	+420 (417) 565616 +420 (417) 564455	tomas.abraham@navijama-hmf.cz www.navijarna-hmf.cz
<b>Czech Republic</b>	Huber CS s.r.o.	Cihlarska 19 602 00 Brno	<b>Phone</b> <b>Fax</b>	+420 541215635 +420 541216835	doskocil@hubercs.cz www.hubercs.cz
<b>Czech Republic</b>	IHR Technika s.r.o	Boleslavská 902 29306 Kosmonosy	<b>Phone</b> <b>Fax</b>	+420 (326) 722716 +420 (326) 320119	Bauer@ihr-tech.cz www.ihr-tech.cz
<b>Denmark</b>	Eegholm A/S	Grundtvigs allé 165-169 (Main office) Jyllandsgade 30, Hal 2 (Stock) 6400 Sønderborg	<b>Phone</b> <b>Fax</b>	+45 (73) 121212 +45 (73) 121213	eegholm@eegholm.dk www.eegholm.dk
<b>Estonia</b>	TECHVITAS OÜ	Tartu mnt 80J 101112 Tallinn	<b>Phone</b>	+372 (56) 700702	info@techvitas.ee www.techvitas.com
<b>Finland</b>	Bauer Gear Motor Finland Oy Ab	Teknobulevardi 3-5 01530 Vantaa	<b>Phone</b>	+358 (207) 189700	info.fi@bauergears.com www.bauergears.com
<b>Finland</b>	Sähkö-Team Oy	Pulttitie 10 00880 Helsinki	<b>Phone</b> <b>Fax</b>	+358 (207) 862330 +358 (207) 862339	korjaamo@sahko-team.fi www.sahko-team.fi
<b>Finland</b>	Tornion Sähköpojat Oy	Raidekatu 29 95420 Tornio	<b>Phone</b> <b>Fax</b>	+358 (400) 222401 +358 (16) 446853	markku.rantapaa@sahkopojat.fi www.sahkopojat.fi
<b>France</b>	Bauer Gear Motor Europe GmbH Succursale France	46, avenue des Frères Lumière 78190 Trappes	<b>Phone</b> <b>Fax</b>	+33 (0) 130132086 +33 (0) 130132088	info.fr@bauergears.com www.bauergears.com
<b>France</b>	Avenel	1, rue Lucien Fromage BP 1 76160 Darnetal (Nord-Quest/Normandie)	<b>Phone</b> <b>Fax</b>	+33 (0) 235085353 +33 (0) 235085608	infos@avenel.fr www.avenel.fr
<b>France</b>	Diceep	17-19 Route Nationale 54 280 Nancy-Laneuvelette (Nord-Est)	<b>Phone</b> <b>Fax</b>	+33 (0) 383290343 +33 (0) 383214613	diceep@diceep.fr www.diceep.fr
<b>France</b>	LM Systèmes SARL	11 Avenue de la Madeleine 33170 Gradignan	<b>Phone</b> <b>Fax</b>	+33 (0) 556754607 +33 (0) 556879150	info@lmsystemes.com www.lmsystemes.com
<b>France</b>	TIMA Transmissions Mécaniques Industrielles des Alpes	33 rue du Béal ZI sud 38400 Saint-Martin-d'Hères	<b>Phone</b> <b>Fax</b>	+33 (0) 476244039 +33 (0) 476629658	b.majoux@tima.fr www.tima.fr
<b>Germany</b>	Bauer Gear Motor GmbH	Eberhard-Bauer-Straße 37 73734 Esslingen	<b>Phone</b> <b>Fax</b>	+49 (711) 3518 0 +49 (711) 3518 381	info@bauergears.com www.bauergears.com
<b>Germany</b>	Bär - Elektromaschinen	Hafenstraße 53 39340 Haldensleben	<b>Phone</b> <b>Fax</b>	+49 (390) 4462589	info@baer-ema.de www.baer-ema.de

# Geared motors for electric overhead conveyors series BM

## Europe



### Europe



<b>Germany</b>	Beck Elektrotechnik	Nürnberg Str. 109 97076 Würzburg	<b>Phone</b> +49 (931) 20050 <b>Fax</b> +49 (931) 2005200	info@team-elektro-beck www.beck-elektrotechnik.de
<b>Germany</b>	Boss Elektromaschinen + Pumpentechnik GmbH	Tankweg 27 44147 Dortmund	<b>Phone</b> +49 (231) 9820220 <b>Fax</b> +49 (231) 98202241	elektromaschinen@boss-gruppe.de www.boss-gruppe.de
<b>Germany</b>	Bühler & Sell Elektromotoren KG	Sprendlinger Landstr. 180 63069 Offenbach	<b>Phone</b> +49 (69) 423076 <b>Fax</b> +49 (69) 423078	info@buehler-sell.de www.buehler-sell.de
<b>Germany</b>	Dent Elektromaschinen GmbH	Grubwaldstr. 30 78224 Singen	<b>Phone</b> +49 (7461) 9697270 <b>Fax</b> +49 (7461) 96972719	info@dent-elektromaschinen.de www.motorenpartner.de
<b>Germany</b>	Elektromaschinenbau Dipl.-Ing. Kögel & Ernst & Co. GmbH	Am Markbach 2 76547 Sinzheim	<b>Phone</b> +49 (7221) 50950 <b>Fax</b> +49 (7221) 509527	info@koegel-ernst.de www.koegel-ernst.de
<b>Germany</b>	elektrotechnik + automation Ulrich Brodbeck GmbH	Gutenbergstr. 5 72631 Aichtal	<b>Phone</b> +49 (7127) 9583 0 <b>Fax</b> +49 (7127) 958317	info@elektrotechnik-automation.de www.elektrotechnik-automation.de
<b>Germany</b>	Elektrowerk Nordhausen Dipl.-Ing. G. Francke Elektromaschinenbau	An der Helme 14 99734 Nordhausen	<b>Phone</b> +49 (3631)47950 <b>Fax</b> +49 (3631)479520	info@elektrowerk-nordhausen.de www.elektrowerk-nordhausen.de
<b>Germany</b>	EMS Elektromotoren GmbH	Gewerbegebiet Egelsee 15 93354 Siegenburg	<b>Phone</b> +49 (9444) 9760 <b>Fax</b> +49 (9444) 976177	bauergear@ems-elektromotoren.de www.ems-elektromotoren.de
<b>Germany</b>	Fuchs Elektromaschinenbau und Vertriebs GmbH	Kaiserstr. 4d 66133 Saarbrücken-Scheidt	<b>Phone</b> +49 (681) 98821690 <b>Fax</b> +49 (681) 98821699	fuch_sb@t-online.de www.elektromaschinenbau-fuchs.de
<b>Germany</b>	Greif GmbH Elektrotechnik	Mushardstraße 11 27570 Bremerhaven	<b>Phone</b> +49 (471) 31997 <b>Fax</b> +49 (471) 303694	info@greif-elektrotechnik.de www.greif-elektrotechnik.de
<b>Germany</b>	Klebs & Hartmann GmbH & Co. KG	August-Heller-Str. 3 67065 Ludwigshafen	<b>Phone</b> +49 (621) 579000 <b>Fax</b> +49 (621) 5790024	e-technik@klebs-hartmann.de www.klebs-hartmann.de
<b>Germany</b>	Wilhelm Kleeberg GmbH & Co.KG E-Motoren E-Werkzeuge	Graf-Zeppelin-Straße 5 24941 Flensburg	<b>Phone</b> +49 (461) 43054110 <b>Fax</b> +49 (461) 43054114	info@kleeberg-fl.de www.kleeberg-fl.de
<b>Germany</b>	Mangold Elektromaschinen- bau GmbH	Lindauer Str. 116 88046 Friedrichshafen	<b>Phone</b> +49 (7541) 500622 <b>Fax</b> +49 (7541) 500630	info@mangold-fn.de www.mangold-fn.de
<b>Germany</b>	Hans Mayer Elektrotechnik GmbH	Simonshofer Str. 41 91207 Lauf a. d. Pegnitz	<b>Phone</b> +49 (912) 32041 <b>Fax</b> +49 (912) 382661	info@hans-mayer-elektrotechnik.de www.hans-mayer-elektrotechnik.de
<b>Germany</b>	Motoren Franke GmbH	Ringstr. 18 01468 Boxdorf	<b>Phone</b> +49 (351) 207680 <b>Fax</b> +49 (351) 2076829	info@motoren-franke.de www.motoren-franke.de
<b>Germany</b>	Polzin Elektromaschinenbau	Kunzestr. 20 04249 Leipzig	<b>Phone</b> +493414250107 <b>Fax</b> +493414250108	info@polzin-elektromaschinenbau.de www.polzin-elektromaschinenbau.de
<b>Germany</b>	Rülke GbR Jens und Uwe Rülke	Auestr. 36 08371 Glauchau	<b>Phone</b> +49 (3763) 5089 0 <b>Fax</b> +49 (3763) 5089 29	info@ruecke-glauchau.de www.ruecke-glauchau.de
<b>Germany</b>	Schulz Systemtechnik GmbH	Schneiderkruger Str. 12 49429 Visbek	<b>Phone</b> +49 (4445) 897 0 <b>Fax</b> +49 (4445) 897 300	info@schulz.st www.schulz-elektrotechnik.de
<b>Germany</b>	Sroczyński GmbH	Pferdestr. 24 48084 Osnabrück	<b>Phone</b> +49 (541) 588443 <b>Fax</b> +49 (541) 588609	info@sroczyński.de www.sroczyński.de/
<b>Germany</b>	Steinlen Elektromaschinen- bau GmbH	Ehlbeek 21 30938 Burgwedel	<b>Phone</b> +49 (5139) 80700 <b>Fax</b> +49 (5139) 807060	info@steinlen.de www.steinlen.de
<b>Germany</b>	Steinlen Elektromaschinen- bau GmbH	Am Schiffbekerberg 18 22111 Hamburg	<b>Phone</b> +49 (40) 7320307 <b>Fax</b> +49 (40) 7322228	info@steinlen.de www.steinlen.de
<b>Germany</b>	UAS Meßtechnik GmbH	Prof.-Hermann-Staudinger-Straße 4 94234 Viechtach	<b>Phone</b> +49 (9942) 94860 <b>Fax</b> +49 (9942) 948610	info@uas.de www.uas.de
<b>Germany</b>	Velden GmbH	Frechener Str. 12 50226 Frechen-Habbelrath	<b>Phone</b> +49 2234 96767 0 <b>Fax</b> +49 2234 96767 29	info@velden-gmbh.de www.velden-gmbh.de
<b>Greece</b>	Drivetech e.p.e.	Chrysostomou Smyrnis 124 18345 Moschato	<b>Phone</b> +30 (210) 7233318 <b>Fax</b> +30 (210) 7233357	info@drivetech.gr www.drivetech.gr
<b>Greenland</b>	Eegholm A/S	Grundtvigs allé 165-169 (Main office) Jyllandsgade 30, Hal 2 (Stock) 6400 Sønderborg / Denmark	<b>Phone</b> +45 (73) 121212 <b>Fax</b> +45 (73) 121213	eegholm@eegholm.dk www.eegholm.dk
<b>Hungary</b>	Schorch Hungary Ltd. Industrial Site	Gyari Street 1 P.O. box 85 3580 Tiszaujvaros	<b>Phone</b> +36 (49) 440877	info@schorchhungaria.hu www.schorchhungaria.hu
<b>Hungary</b>	BC Ongroelektro. Kft.	Bolyai tér 1. 3702 Kazincbarcika (East Hungary)	<b>Phone</b> +36 (48) 511186 <b>Fax</b> +36 (48) 712771	toth.tibor@borsodchem.hu
<b>Ireland</b>	Avonmore Electrical (Dublin) Ltd. Part of the Avonmore Group	Unit D2 Airton Business Park Airton Road, Tallaght 24 Dublin	<b>Phone</b> +353 (1) 462 8333 <b>Fax</b> +353 (1) 462 8333	eoin@avonmore-electrical.com www.avonmore-electrical.com



### Europe



<b>Italy</b>	Bauer Gear Motor Europe GmbH	Viale Veneto 48 35020 Saonara (PD)	<b>Phone</b>	+39 (49) 8792327	bauer.it@bauergears.com www.bauergears.com/it/
<b>Italy</b>	Ma.In s.n.c.	Via Pola, 8 I-10135 Torino	<b>Phone</b> <b>Fax</b>	+39 (11) 34733 25 +39 (11) 39133 56	dibello.e@ma-in.com www.ma-in.com
<b>Italy</b>	Assyservice	Via Chieppara, 14 int. 1 45011 Adria ( RO )	<b>Phone</b> <b>Fax</b>	+39 (426) 1903888 +39 (426) 1903694	info@assyservice.com www.assyservice.com
<b>Latvia</b>	Techvitas SIA	38 Daugavas Street 2167 Marupe, Marupes nov.	<b>Phone</b>	+371 (22) 325004	info@techvitas.lv www.techvitas.com
<b>Lithuania</b>	Techvitas UAB	Dubysos str. 66A 94107 Klaipeda	<b>Phone</b>	+370 46355494	info@techvitas.lt www.techvitas.com
<b>Luxembourg</b>	Bauer Gear Motor Europe GmbH Office Belgium	p/a Regus Pastoor Cooremansstraat 3 1702 Groot-Bijgaarden / Belgium	<b>Phone</b> <b>Fax</b>	+32 (0) 28937280	info.be@bauergears.com www.bauergears.com
<b>Macedonia</b>	Indas Industry Assistance d.o.o.	Heroja Pinkija 95 21000 Novi Sad / Serbia and Montenegro	<b>Phone</b> <b>Fax</b>	+381 (21) 4804800 +381 (21) 4804808	office@indas.rs www.indas.rs
<b>Netherlands</b>	Bauer Gear Motor Europe GmbH Office Belgium	p/a Regus Pastoor Cooremansstraat 3 1702 Groot-Bijgaarden / Belgium	<b>Phone</b>	+32 (0) 28937280	info.be@bauergears.com www.bauergears.com
<b>Netherlands</b>	Facta Friesland BV	De Alde Mar 11 9035 VP Dronryp	<b>Phone</b> <b>Fax</b>	+31 (0)517 231232	friesland@facta.nl www.facta.nl
<b>Netherlands</b>	De Bruyn B.V.	Van Konijnenburgweg 105 4612 PL Bergen op Zoom	<b>Phone</b> <b>Fax</b>	+31 (164) 234302 +31 (164) 255140	repair@de-bruyn.nl www.de-bruyn.nl
<b>Netherlands</b>	Facta Zevenhuizen BV	Nijverheidscentrum 36 2761 JP Zevenhuizen	<b>Phone</b>	31 (88) 7384702	zevenhuizen@facta.nl www.facta.nl
<b>Netherlands</b>	Facta Nederweert BV	Pannenweg 208 6031 RK Nederweert	<b>Phone</b> <b>Fax</b>	+31 (495) 634141	31 (88) 7384702 www.facta.nl
<b>Netherlands</b>	Facta Uitgeest BV	Westerwerf 11 1911 JA Uitgeest	<b>Phone</b> <b>Fax</b>	+31 (88) 6000200	uitgeest@facta.nl www.facta.nl
<b>Netherlands</b>	Facta Staphorst BV	Roelof Brinkstraat 3 7951 DW Staphorst	<b>Phone</b> <b>Fax</b>	+31 (88) 7384700	straphorst@facta.nl www.facta.nl
<b>Netherlands</b>	Facta Appingedam BV	Holepolder 1 9902 SM Appingedam	<b>Phone</b>	+31 (88) 7384700	appingendam@facta.nl www.facta.nl
<b>Norway</b>	BAUER Gearmotorer AS	Postboks 221 2021 Skedsmokorset	<b>Phone</b>	+47 (63) 875950	bauergear@bauergear.no www.bauergear.no
<b>Poland</b>	Steinlen Polska Sp. z o.o.	ul. W. Grabskiego 4/8 63-500 Ostrzeszów	<b>Phone</b> <b>Fax</b>	+48 (62) 7322352 +48 (62) 7322351	biuro@steinlenpolska.pl www.steinlenpolska.pl
<b>Portugal</b>	TEM S.L. Bauer Gear Center Transmisiones Electromecánicas, S.L.	Pol. Industrial Les Comes Calle Italia 11 Nave 9 08700 Igualada (Barcelona) / Spain	<b>Phone</b> <b>Fax</b>	+34 (93) 8056021 +34 (93) 8056022	info@tem-sl.com www.tem-sl.com
<b>Romania</b>	BIBUS SES srl	Calea Lugojului 134/1 307200 Ghironda, Timis	<b>Phone</b>	+40 (256) 200500	office@bibus.ro www.bibus.ro
<b>Serbia and Montenegro</b>	Indas Industry Assistance d.o.o.	Heroja Pinkija 95 21000 Novi Sad	<b>Phone</b> <b>Fax</b>	+381 (21) 4804800 +381 (21) 4804808	office@indas.rs www.indas.rs
<b>Slovakia</b>	Bauer Gear Motor Slovakia	Továrenská 49 953 36 Zlaté Moravce	<b>Phone</b> <b>Fax</b>	+421 (37) 6926158 +421 (37) 6926181	bauer.sk@bauergears.com www.bauergears.com
<b>Slovakia</b>	Transmisie Engineering a.s.	P. Mudrona 10 036 01 Martin	<b>Phone</b>	+421 (43) 4133157	dps@transmisie.sk www.transmisie.sk
<b>Slovenia</b>	TALER ING d.o.o.	Jelovška cesta 43A 4264 Bohinjska Bistrica	<b>Phone</b> <b>Fax</b>	+386 (4) 5747128 +386 (4) 5747129	info@taler-ing.si www.taler-ing.si
<b>Spain</b>	TEM S.L. Bauer Gear Center Transmisiones Electromecánicas, S.L.	Pol. Industrial Les Comes Calle Italia 11 Nave 9 08700 Igualada (Barcelona) / Spain	<b>Phone</b> <b>Fax</b>	+34 (93) 8056021 +34 (93) 8056022	info@tem-sl.com www.tem-sl.com
<b>Sweden</b>	BAUER Gearmotorer Sverige AB	Årjängsvägen 4 66693 Gustavsfors	<b>Phone</b> <b>Fax</b>	+46 (531) 20050 +46 (531) 20040	postmaster@bauergear.net
<b>Switzerland</b>	Küffer Elektro-Technik AG	Industrie Neuhof 31 3422 Kirchberg	<b>Phone</b>	+41 (34) 4452626	info@ketag.ch www.ketag.ch
<b>Switzerland</b>	Electro-Müller AG	Industriestr. 25 2555 Brügg	<b>Phone</b> <b>Fax</b>	+41 (32) 3441010 +41 (32) 3441019	info@electro-mueller.ch www.electro-mueller.ch
<b>United Kingdom</b>	Bauer Gear Motor Limited	Unit1 Nat Lane Business Park CW7 3BS Winsford	<b>Phone</b> <b>Fax</b>	+44 (1606) 868600 +44 (1606) 868603	info.uk@bauergears.com www.bauergears.com

# Geared motors for electric overhead conveyors series BM

## Eastern Europe



### Eastern Europe



<b>Armenia</b>	Bauer Gear Motor GmbH	Eberhard-Bauer-Str. 37 73734 Esslingen / Germany	<b>Phone</b> <b>Fax</b>	+49 (711) 3518 0 +49 (711) 3518 381	info@bauergears.com www.bauergears.com
<b>Azerbaijan</b>	Bauer Gear Motor GmbH	Eberhard-Bauer-Str. 37 73734 Esslingen / Germany	<b>Phone</b> <b>Fax</b>	+49 (711) 3518 0 +49 (711) 3518 381	info@bauergears.com www.bauergears.com
<b>Georgia</b>	Bauer Gear Motor GmbH	Eberhard-Bauer-Str. 37 73734 Esslingen / Germany	<b>Phone</b> <b>Fax</b>	+49 (711) 3518 0 +49 (711) 3518 381	info@bauergears.com www.bauergears.com
<b>Kazakhstan</b>	Bauer Gear Motor GmbH	Eberhard-Bauer-Str. 37 73734 Esslingen / Germany	<b>Phone</b> <b>Fax</b>	+49 (711) 3518 0 +49 (711) 3518 381	info@bauergears.com www.bauergears.com
<b>Kazakhstan</b>	Silumin-Vostok	Revolucionnaya st., 10 070010 Ust-Kamenogorsk	<b>Phone</b> <b>Fax</b>	+7 (7232) 558982 +7 (7232) 552058	info@silumin.kz
<b>Ukraine</b>	LLC Industrial Mechanics	Michurina str. 4 Dnepr	<b>Phone</b> <b>Fax</b>	+38 (099) 1194979	director@ind-mech.com www.ind-mech.com
<b>Uzbekistan</b>	Bauer Gear Motor GmbH	Eberhard-Bauer-Str. 37 73734 Esslingen / Germany	<b>Phone</b> <b>Fax</b>	+49 (711) 3518 0 +49 (711) 3518 381	info@bauergears.com www.bauergears.com



# Geared motors for electric overhead conveyors series BM

## Middle East & Africa



### Middle East & Africa



<b>Bahrain</b>	KUHNEZUG AG	C-1401, 14th Floor Ontario Tower Business Bay Dubai / United Arab Emirates	<b>Phone</b> <b>Fax</b>	+971 (4) 5722117 +971 (4) 2567 125	info@kuhnezugag.com www.kuhnezugag.ae
<b>Botswana</b>	Bauer a Division of Hudaco Trading (Pty) Ltd.	72 Acacia Road 1401 Primrose / South Africa	<b>Phone</b> <b>Fax</b>	+27 (11) 8289715 +27 (11) 8224135	home@gbauer.co.za www.gbauer.co.za
<b>Ethiopia</b>	KUHNEZUG AG	C-1401, 14th Floor Ontario Tower Business Bay Dubai / United Arab Emirates	<b>Phone</b> <b>Fax</b>	+971 (4) 5722117 +971 (4) 2567 125	info@kuhnezugag.com www.kuhnezugag.ae
<b>India</b>	Bauer Gear Motor GmbH	Eberhard-Bauer-Straße 37 73734 Esslingen / Germany	<b>Phone</b> <b>Fax</b>	+49 (711) 35180 +49 (711) 3518381	info@bauergears.com www.bauergears.com
<b>India</b>	International Combustion (India) Ltd.	Infinity Benchmark, 11th Floor, Plot – G1, Block – EP & GP, Salt Lake Electronics Complex, 700 091 Kolkata	<b>Phone</b> <b>Fax</b>	+91 (33) 33153000 +91 (33) 23576653	info@internationalcombustion.in
<b>Israel</b>	Greenshpon Engineering Works Ltd.	Bar-Lev Industrial Park 20179 Misgav	<b>Phone</b> <b>Fax</b>	+972-4-9913181 +972-4-9913477	info@greenshpon-eng.com www.greenshpon-eng.com
<b>Jordan</b>	KUHNEZUG AG	C-1401, 14th Floor Ontario Tower Business Bay Dubai / United Arab Emirates	<b>Phone</b> <b>Fax</b>	+971 (4) 5722117 +971 (4) 2567 125	info@kuhnezugag.com www.kuhnezugag.ae
<b>Kuwait</b>	KUHNEZUG AG	C-1401, 14th Floor Ontario Tower Business Bay Dubai / United Arab Emirates	<b>Phone</b> <b>Fax</b>	+971 (4) 5722117 +971 (4) 2567 125	info@kuhnezugag.com www.kuhnezugag.ae
<b>Mozambique</b>	Bauer a Division of Hudaco Trading (Pty) Ltd.	72 Acacia Road 1401 Primrose / South Africa	<b>Phone</b> <b>Fax</b>	+27 (11) 8289715 +27 (11) 8224135	home@gbauer.co.za www.gbauer.co.za
<b>Namibia</b>	Bauer a Division of Hudaco Trading (Pty) Ltd.	72 Acacia Road 1401 Primrose / South Africa	<b>Phone</b> <b>Fax</b>	+27 (11) 8289715 +27 (11) 8224135	home@gbauer.co.za www.gbauer.co.za
<b>Oman</b>	KUHNEZUG AG	C-1401, 14th Floor Ontario Tower Business Bay Dubai / United Arab Emirates	<b>Phone</b> <b>Fax</b>	+971 (4) 5722117 +971 (4) 2567 125	info@kuhnezugag.com www.kuhnezugag.ae
<b>Qatar</b>	KUHNEZUG AG	C-1401, 14th Floor Ontario Tower Business Bay Dubai / United Arab Emirates	<b>Phone</b> <b>Fax</b>	+971 (4) 5722117 +971 (4) 2567 125	info@kuhnezugag.com www.kuhnezugag.ae
<b>Saudi Arabia</b>	KUHNEZUG AG	C-1401, 14th Floor Ontario Tower Business Bay Dubai / United Arab Emirates	<b>Phone</b> <b>Fax</b>	+971 (4) 5722117 +971 (4) 2567 125	info@kuhnezugag.com www.kuhnezugag.ae
<b>South Africa</b>	Bauer a Division of Hudaco Trading (Pty) Ltd.	72 Acacia Road 1401 Primrose	<b>Phone</b> <b>Fax</b>	+27 (11) 8289715 +27 (11) 8224135	johnB@gbauer.co.za
<b>Swaziland</b>	Bauer a Division of Hudaco Trading (Pty) Ltd.	72 Acacia Road 1401 Primrose	<b>Phone</b> <b>Fax</b>	+27 (11) 8289715 +27 (11) 8224135	johnB@gbauer.co.za
<b>Syrian Arab Republic</b>	KUHNEZUG AG	C-1401, 14th Floor Ontario Tower Business Bay Dubai / United Arab Emirates	<b>Phone</b> <b>Fax</b>	+971 (4) 5722117 +971 (4) 2567 125	info@kuhnezugag.com www.kuhnezugag.ae
<b>Turkey</b>	CEFIP - Makina & Endüstriyel Ürünler San. ve Dis Tic. Ltd. Sti.	Perpa Ticaret Merkezi A Blok Kat: 2 No: 9-0033 34384 Okmeydani - Istanbul	<b>Phone</b> <b>Fax</b>	+90 (212) 2101890 +90 (212) 2101597	cefip@cefip.com.tr www.cefip.com.tr
<b>Turkey</b>	CEFIP- Consulting & Engineering für Industrie-Produkte GmbH	Heidstraße 80 44649 Herne / Germany	<b>Phone</b> <b>Fax</b>	+49 (2325) 972580 +49 (2325) 9725825	contact@cefip.de www.cefip.de
<b>United Arab Emirates</b>	KUHNEZUG AG	C-1401, 14th Floor Ontario Tower Business Bay Dubai / United Arab Emirates	<b>Phone</b> <b>Fax</b>	+971 4 2525711 +971 4 2567125	info@kuhnezugag.com www.kuhnezugag.ae
<b>Yemen</b>	KUHNEZUG AG	C-1401, 14th Floor Ontario Tower Business Bay Dubai / United Arab Emirates	<b>Phone</b> <b>Fax</b>	+971 (4) 5722117 +971 (4) 2567 125	info@kuhnezugag.com www.kuhnezugag.ae
<b>Zimbabwe</b>	Bauer a Division of Hudaco Trading (Pty) Ltd.	72 Acacia Road 1401 Primrose / South Africa	<b>Phone</b> <b>Fax</b>	+27 (11) 8289715 +27 (11) 8224135	home@gbauer.co.za www.gbauer.co.za

# Geared motors for electric overhead conveyors series BM

## APAC



### A P A C



<b>Australia</b>	Altra Industrial Motion Pty Ltd	Unit 1, 11 Penny Place Arndell Park 2148 NSW (Sydney)	<b>Phone</b>	+61 (2) 9622 1333	Philip.Cairns@altramotion.com.au www.altramotion.com
<b>Indonesia</b>	PT. Cahaya Mekar Sejati	Jl. Agung Utara Raya Blok A36 D/46 14350 Jakarta	<b>Phone</b> <b>Fax</b>	+62 (21) 6401803 +62 (21) 64715082	cahkarti@cbn.net.id www.bauergearmotor.com
<b>Japan</b>	Leybold Co., Ltd.	5th Floor, Tokyo Tatemono Bldg 1-9-9, Yaesu 1-Chome, Chuo-Ku 103-0028 Tokyo	<b>Phone</b> <b>Fax</b>	+81 (3) 32721861 +81 (3) 32814490	koki@leybold-kk.com
<b>Korea, Republic Of</b>	Chemiko Trading Co. Ltd.	43,Teheran-ro 38-gil, Gangnam-gu 06222 Seoul	<b>Phone</b> <b>Fax</b>	+82 (2) 5675336 +82 (2) 5541284	chemiko@chol.com www.chemiko.net
<b>Malaysia</b>	AVM DIESEL (M) SDN BHD	No. 20-1, Jalan Kemuning Prima F33/F Kemuning Utama, Seksyen 33 Shah Alam 40400 Selangor	<b>Phone</b> <b>Fax</b>	+60 (3) 51201281 +60 (3) 51201281	sales@avmdiesel.com www.avmdiesel.com
<b>Philippines</b>	Optima Equipment Corporation	G/F OPTIMA Building, 883 J. Aguilar Avenue 1740 Baranggay Pamplona Tres, Las Pinas City	<b>Phone</b> <b>Fax</b>	+63 (2) 86601230 +63 (2) 8695100	vandel@optima-equipment.com
<b>Singapore</b>	AVM Diesel (F.E.) Pte Ltd Gear Centre Southeast Asia	BLK 27 TUAS AVE 13 #01-23 638993 Singapore	<b>Phone</b> <b>Fax</b>	+65 (6) 8636933 +65 (6) 8636900	sales@avmdiesel.com www.avmdiesel.com
<b>Taiwan</b>	Saturn Power Ltd.	28F, No.27-3, Sec.2 Chung Cheng E. Rd. Danshui District 25170 New Taipei City	<b>Phone</b> <b>Fax</b>	+886 (2) 8809 8186 +886 (2) 8809 8187	sales@saturnpowerltd.com www.saturnpowerltd.com
<b>Thailand</b>	Kasetphand Industry Co.,LTD	100 M. 3 SOI Suksawad 76 Suksawad rd. Bangjark, Phrapradaeng 10130 Samutprakarn	<b>Phone</b> <b>Fax</b>	+66 (2) 8176410 +66 (2) 8176437	jaruwat@ksp.co.th www.ksp.co.th
<b>Vietnam</b>	GNN CO., LTD.	33 Hoa hong 2, W. 2 Phu Nhuan District	<b>Phone</b> <b>Fax</b>	+84 (8) 35174923 +84 (8) 35174924	http://www.gnnvietnam.com



### C h i n a



<b>China</b>	<b>Altra Industrial Motion (ShenZhen) Co., Ltd.</b>	Suite 301,#5 Lihpao Plaza 88 Shenbin Road Minhang District 201106 Shanghai	<b>Phone</b> +86 (21) 5169 9255 <b>Fax</b> +86 (21) 6248 5387	info.china@bauergears.com.cn
<b>Hong Kong</b>	<b>A-CALL Company</b>	Flat 8A, 8th Floor Wing Cheong Industrial Building 109 How Ming Street Kwun Tong Kowloon	<b>Phone</b> +852 (27) 930250 <b>Fax</b> +852 (27) 930620	kent@a-call.com.hk www.a-call.com.hk

# Energy Efficient Geared Motors

## Electric overhead conveyors series BM

---

### Notes



# Energy Efficient Geared Motors

## Electric overhead conveyors series BM

---

### Notes

# Mounting Positions

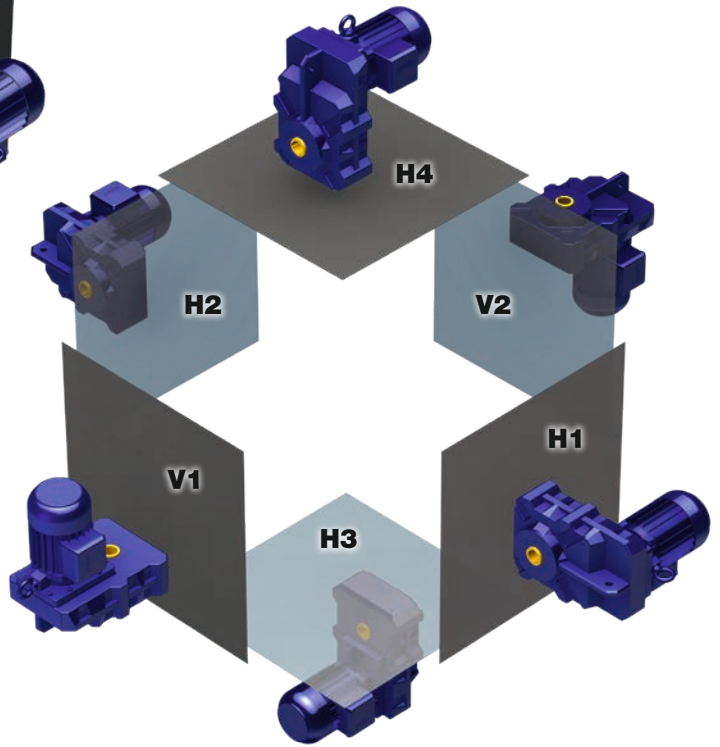
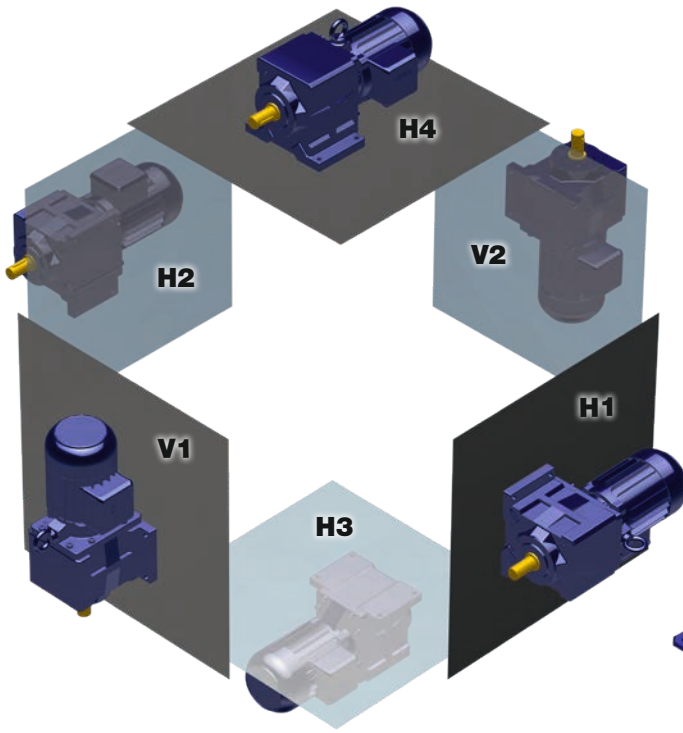

## Helical Geared Motors

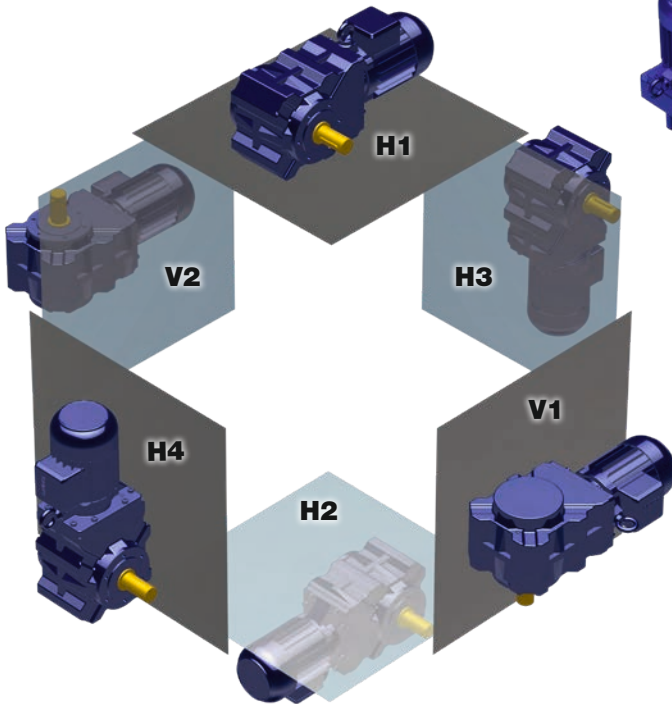

## Parallel Shaft Geared Motors

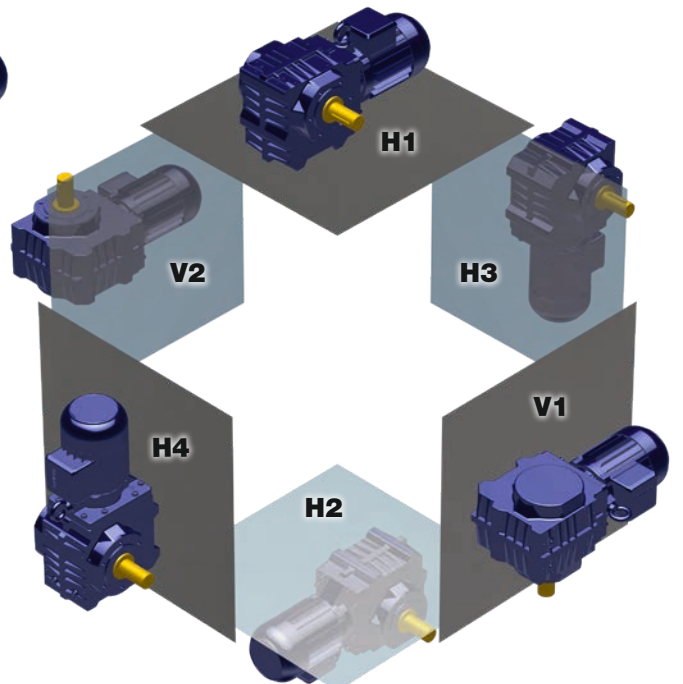

## Bevel Geared Motors

## Worm Geared Motors

## Bauer Gear Motor Facilities

### Europe

#### Germany

Eberhard-Bauer-Str. 37  
73734 Esslingen - Germany  
+49 711 3518 0

#### Slovakia

Továrenská 49  
953 01 Zlaté Moravce - Slovakia  
+421 37 6926100

#### United Kingdom

Unit 1, Nat Lane Business Park  
Winsford, Cheshire  
CW7 3BS - United Kingdom  
+44 1606 868600

### North America

#### Charlotte, NC

701 Carrier Drive  
Charlotte, NC 28216 - USA  
+1 800-387-0130

### Asia Pacific

#### China

No. 18 HuanZhen Road  
Dabo Industrial Zone - BoGoang  
Village ShaJing Town - BaoAn District  
518104 Shenzhen City  
Guangdong Province - China  
+86 755 27246308

### Customer Service

#### Belgium

1702 Groot-Bijgaarden  
+32 2 89372080

#### Finland

01530 Vantaa  
+358 207 189700

#### France

1702 Groot-Bijgaarden  
+32 2 89372080

#### Italy

35020 Padova (PD)  
+39 049 8792327

#### China

Suite 301, #5 Lihpao Plaza,  
88 Shen bin Road, Min hang District,  
201106 Shanghai, China  
Sales Enquiry : +86 (21) 5169 9255  
Service hotline : +86 187 0171 2972



Scan to see all  
the brands of  
Regal Rexnord

Neither the accuracy nor completeness of the information contained in this publication is guaranteed by the company and may be subject to change in its sole discretion. The operating and performance characteristics of these products may vary depending on the application, installation, operating conditions and environmental factors. The company's terms and conditions of sale can be viewed at <https://www.bauergears.com/terms-and-conditions/sales-terms-and-conditions>. These terms and conditions apply to any person who may buy, acquire or use a product referred to herein, including any person who buys from a licensed distributor of these branded products.

©2023 by Bauer Gear Motor GmbH. All rights reserved. All trademarks in this publication are the sole and exclusive property of Bauer Gear Motor GmbH or one of its affiliated companies.

Images: Fotolia, Adobe Stock, Regal Rexnord and Bauer Archives