



*your reliable partner*

## ROBA®-duplostop®

the perfect elevator brake  
for compact drives



## ROBA<sup>®</sup>-duplostop<sup>®</sup> the doubled safety brake for elevator drives

### Performance Characteristics

- Highest safety system of two independent brakes according to EN 81-1/A3
- Also licensed as protection against excessive upward speeds when fitted with release monitoring (prototype-inspected ABV 766/3)
- Exceptionally short construction
- Cost-effective redundant elevator brake
- Brakes can be individually switched and inspected
- Mounting the encoder does not lengthen the construction
- Installation of microswitches for function monitoring possible
- Simple installation
- No air gap adjustment necessary
- Virtually silent due to patented *mayr*<sup>®</sup> noise damping
- Brake release via rotating hand release is a possible option



#### Function

Both brake circuits on the ROBA<sup>®</sup>-duplostop<sup>®</sup> safety brakes brake when the springs are applied, i.e. in energised operating condition, the electromagnetic brake is open. After the power is switched off or after unforeseeable power failures, both brake circuits automatically close, actuated through spring force, and thus reliably ensure static holding or dynamic deceleration of the moving elevator cabin in any operating situation.

#### Simple installation

The compact brake design, which is easy to assemble, permits short brake assembly times. After the brakes have been mounted, no further adjustment work is required, as the working air gap and release monitoring have already been adjusted for reliable function at the factory. In this way, possible malfunctions due to mounting or adjustment errors are excluded through the design.

#### Maintenance-free

The ROBA<sup>®</sup>-duplostop<sup>®</sup> safety brake is mainly maintenance-free. The maintenance work is limited to an inspection of the brake linings. These friction linings, however, are extremely wear-resistant, and have a very long lifetime.

#### Virtually silent

ROBA<sup>®</sup>-duplostop<sup>®</sup> brakes operate extremely quietly due to the patented *mayr*<sup>®</sup> noise damping system.

#### TÜV (German Technical Inspectorate) Certificate:

The brakes are prototype-inspected by the Southern German Technical Inspectorate (TÜV) for their effect as a brake assembly on the drive sheave shaft and as part of the protective assembly against excessive upward-moving cage speeds.

Certificate number: **ABV 766/3 and ESV 766/1**

#### Design

The ROBA<sup>®</sup>-duplostop<sup>®</sup> brake is a redundant safety brake with two cuboid individual brakes arranged next to each other. This permits an extremely short construction length depending on the construction type. Even the addition of a compact encoder does not alter this length, as it is neatly positioned between the two brakes. All ROBA<sup>®</sup>-duplostop<sup>®</sup> safety brakes are designed for a duty cycle of 60 % with operating mode S3 as a standard measure. All metal surfaces are phosphated for protection against corrosion.

### Order Number

Basic Type		0	0	Basic Type	
Manually actuated using rotating hand release		1	1	With release monitoring <sup>3)</sup>	
With rotating hand release for bowden cable <sup>2)</sup>		2	2	With wear monitoring	
			3	With release <sup>3)</sup> and wear monitoring	

—	/	8	0	1	0	.	—	—	—	—	3	/	—	/	—
▲							▲	▲					▲		▲
<b>Size</b>		Nominal braking torque	0	0	without hub / elastomer damping		Braking Torque				Coil voltage <sup>2)</sup>				
<b>200</b>		100 %	1	1	with hub / elastomer damping		(see Technical				24, 104, 180, 207				
<b>up to</b>		Braking torque increased <sup>1)</sup>	2	2	without hub / cup spring damping		Data, page 3				[V DC]				
<b>1500</b>		Braking torque reduced	3	3	with hub / cup spring damping		and 4)								

Example: 200 / 8010.20233 / 2 x 150 Nm / 207 V DC

1) Operation with overexcitation (1,5 to 2 x the nominal voltage) necessary.

2) We recommend connection via smoothed DC voltage or the application of a *mayr*<sup>®</sup>-bridge rectifier / *mayr*<sup>®</sup>-ROBA<sup>®</sup>-switch fast acting rectifier.

3) Release monitoring through mechanically-actuated microswitches or through optional contactless proximity switches (see page 7).

## ROBA®-duplostop® Type 8010. \_ \_ \_ 3

Drilling pattern for encoder available on request

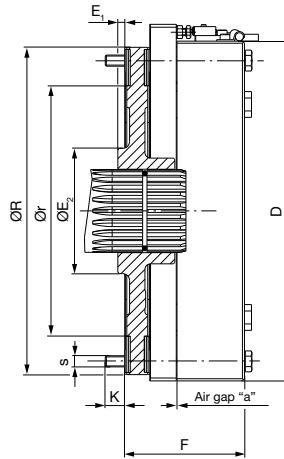
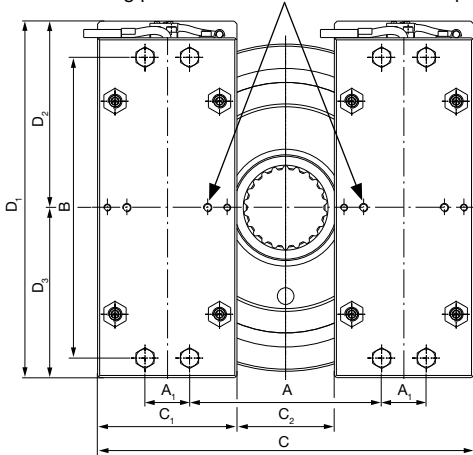

Rotating hand release  
Type 8010. \_ 2\_3

Dimensions		Size					
		200 <sup>4)</sup>		400		600	
		short	long	short	long	short	long
Splined shaft *, ** DIN 5480 Ø d <sub>s</sub> x m x z		60 x 2,5 x 22	65 x 3 x 20	65 x 3 x 20	72 x 3 x 22	72 x 3 x 22	
		65 x 3 x 20	67 x 3 x 21	67 x 3 x 21	82 x 3 x 26	82 x 3 x 26	82 x 3 x 26
		67 x 3 x 21	72 x 3 x 22	72 x 3 x 22	90 x 3 x 28		90 x 3 x 28
A	variable on request	138	117	153	128	165	190
A <sub>1</sub>		32	28	42	42	50	50
B		216	236	238	258	264	300
C	variable on request	270	245	315	290/335	355	380
C <sub>1</sub>		100	100	120	120	140	140
C <sub>2</sub>	variable on request	70	45	75	50/95	75	100
D		244	264	268	290	298	334
D <sub>1</sub>		256	276	280	303	311	347
D <sub>2</sub>		134	144	146	157	162	180
D <sub>3</sub>		122	132	134	146	149	167
E <sub>1</sub>	Type 8010.0_2_ _ 3	5	5	17	17	25	-
	Type 8010.1_ _ 3	5	5	17	21	25	21
E <sub>2</sub>		90	90	90	90	110	132
F	Type 8010.0_2_ _ 3	86,1	91,1	96,1	101,1	101,1	-
	Type 8010.1_ _ 3	91,1	91,1	96,1	101,1	101,1	108,1
K	Type 8010.0_2_0_ _ 3	14	20	14	19	19	-
	Type 8010.1_0_ _ 3	19	19	14	19	19	22
r		180	180	200	200/212	220/210	250
R		235	235	253	253/281	281	315
s		8 x M8	8 x M8	8 x M10	8 x M10	8 x M12	8 x M12

Technical Data			Size						
			200		400		600		
			short	long	short	long	short	long	
Nominal braking torque Type 8010.0_ _ 3	M <sub>nom</sub>	[Nm]	2 x 200	2 x 270	2 x 410	2 x 430/480	2 x 590	2 x 730	
Increased braking torque <sup>1)</sup> Type 8010.1_ _ 3	M	[Nm]	2 x 220	-	-	2 x 490/540	2 x 640	2 x 780	
			2 x 240	2 x 290	-	-	2 x 670	-	
Reduced braking torques up to: Type 8010.2_ _ 3	M	[Nm]	2 x 100	2 x 250	2 x 210/280	2 x 375	2 x 500	2 x 700	
Electrical nominal power Type 8010.0_ _ 3	P <sub>20</sub>	[W]	2 x 74	2 x 77	2 x 93	2 x 92	2 x 86	2 x 96	
Weight		[kg]	27	29	36,6	43,5	51,6	61,9	
Speed	Maximum speed	n <sub>max</sub>	[rpm]	1200	1100	1000	1000	800	800
	inspected max. speed in the elevator area as a type-examination tested brake	n	[rpm]	810	820	710	1000	500	500
Nominal air gap (tolerance +0,15/-0,05)	a	[mm]	0,45						

## ROBA®-duplostop® Type 8010.\_\_\_\_3

Drilling pattern for encoder available on request

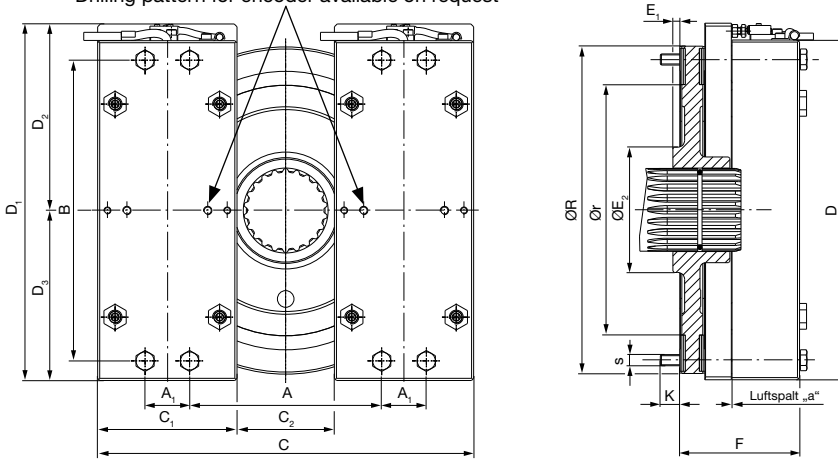

## Sizes 800 up to 1500

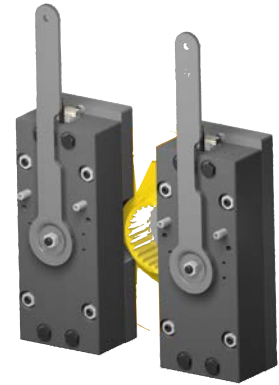

Rotating hand release manually actuated  
Type 8010.\_\_\_\_1\_3

Dimensions		Size		
		800	1000	1500
Splined shaft *, ** DIN 5480	Type 8010.0____3	82 x 3 x 26	90 x 3 x 28	95 x 3 x 30
	Type 8010.1____3	90 x 3 x 28	98 x 4 x 23	98 x 4 x 23
Ø d <sub>B</sub> x m x z	Type 8010.1____3	98 x 4 x 23	-	-
A	variable on request	169	175	210
A <sub>1</sub>		56	60	70
B		300	342	410
C	variable on request	375	395	480
C <sub>1</sub>		150	160	200
C <sub>2</sub>	variable on request	75	75	80
D		336	380	458
D <sub>1</sub>		349	393	458
D <sub>2</sub>		181	203	
D <sub>3</sub>		168	190	
E <sub>1</sub>	Type 8010.0____3	20	22,5	44
	Type 8010.1____3	20	22,5	
E <sub>2</sub>		124	132	150
F	Type 8010.0____3	108,1	108,1	116
	Type 8010.1____3	108,1	108,1	
K	Type 8010.0____0_3	22	22	21
	Type 8010.1____0_3	22	22	
r		250	280	336
R		315	348	418
s		8 x M12	8 x M16	8 x M16

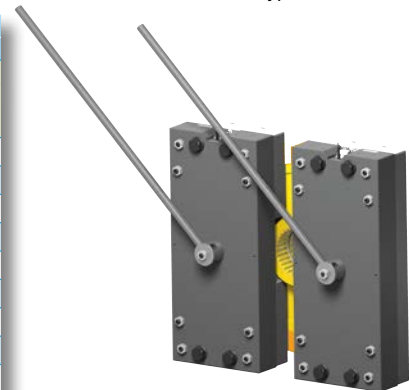

Rotating hand release manually actuated  
(insertable)  
Type 8010.\_\_\_\_1\_3  
Size 1500

\* Design with hub available on request  
(Recommended tolerance hub-shaft H7/k6)  
\*\* Spline length on request  
1) Operation with overexcitation (1,5 to 2  
x the nominal voltage) necessary.

Technical Data			Size			
			800	1000	1500	
Nominal braking torque Type 8010.0____3	M <sub>nom</sub>	[Nm]	2 x 830	2 x 1015	2 x 1700	
Increased braking torque <sup>1)</sup> Type 8010.1____3	M	[Nm]	2 x 930	2 x 1200	-	
			2 x 900	-	-	
Reduced braking torques up to: Type 8010.2____3	M	[Nm]	2 x 650	2 x 920	2 x 1250	
Electrical nominal power Type 8010.0____3	P <sub>20</sub>	[W]	2 x 118	2 x 121	2 x 152	
Weight		[kg]	66,5	83	139	
Speed	Maximum speed	n <sub>max</sub>	[rpm]	600	500	400
	inspected max. speed in the elevator area as a type- examination tested brake	n	[rpm]	400	400	400
Nominal air gap (tolerance +0,15/-0,05)	a	[mm]		0,45		

Braking torque tolerance 0 % / +60 %.

We reserve the right to make dimensional and constructional

## Electrical Accessories – Functions of the DC Voltage Modules

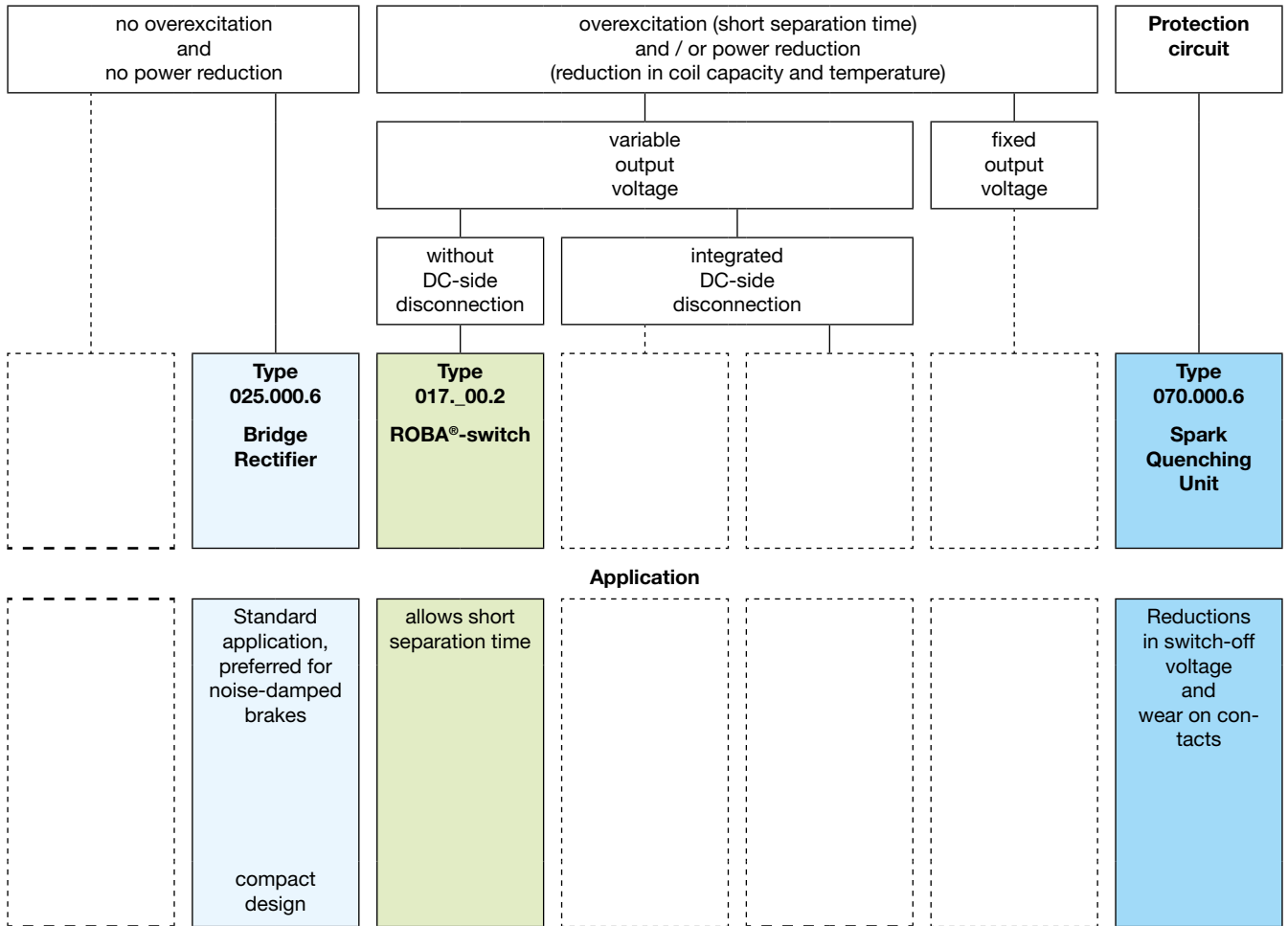

**Example**

Available: mains voltage 230 VAC  
 Wanted: short separation time (overexcitation)  
 Required: supply module / coil nominal voltage

**Solution:**

- Supply module: Type 017.\_00.2
- Coil nominal voltage: 104 VDC

**For detailed information on our DC voltage modules, please go to:**  
[www.mayr.com](http://www.mayr.com)

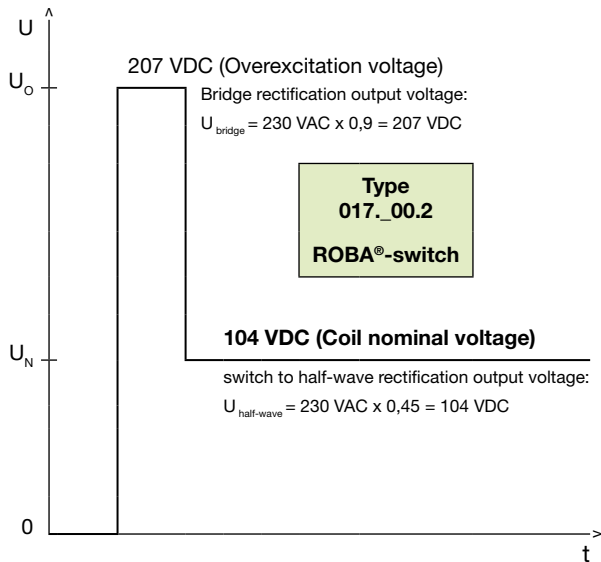

## Spark Quenching Unit Type 070.000.6



### Application

Reduces spark production on the switching contacts occurring during DC-side switch-off of inductive loads.

- Voltage limitation according to VDE 0580 2000-07, Item 4.6.
- Reduction of EMC-disturbance by voltage rise limitation, suppression of switching sparks.
- Reduction of brake engagement times by a factor of 2 – 4 compared to freewheeling diodes.



### Function

The spark quenching unit will absorb voltage peaks resulting from inductive load switching, which can cause damage to insulation and contacts. It limits these to 70 V and reduces the contact load. Switching products with a contact opening distance of > 3 mm are suitable for this purpose.

## ROBA<sup>®</sup>-switch Type 017.\_00.2



### Application

ROBA<sup>®</sup>-switch fast acting rectifiers are used to connect DC consumers to alternating voltage supplies, for example electromagnetic brakes and clutches (ROBA-stop<sup>®</sup>, ROBA<sup>®</sup>-quick, ROBATIC<sup>®</sup>) as well as electromagnets, electrovalves, etc.

#### Fast acting rectifier ROBA<sup>®</sup>-switch 017.\_00.2

- Consumer operation with overexcitation or power reduction
- Input voltage: 100 – 500 VAC
- Maximum output current  $I_{RMS}$  : 3 A at 250 VAC
- UL-approved

### Function

The ROBA<sup>®</sup>-switch units are used for operation at an input voltage of between 100 and 500 VAC, dependent on size. They can switch internally from bridge rectification output voltage to half-wave rectification output voltage. The bridge rectification time can be modified from 0,05 to 2 seconds by exchanging the external resistor ( $R_{ext}$ ).



#### Calculation output voltage

Holding voltage	$VDC = VAC \times 0,45$
Overexcitation voltage	$VDC = VAC \times 0,9$

## Bridge rectifier Type 025.000.6



### Application

Rectifiers are used to connect DC consumers to alternating voltage supplies, for example electromagnetic brakes and clutches (ROBA-stop<sup>®</sup>, ROBA-quick<sup>®</sup>, ROBATIC<sup>®</sup>), electromagnets, electrovalves, contactors, switch-on safe DC motors, etc.

### Function

The AC input voltage (VAC) is rectified (VDC) in order to operate DC voltage units. Also, voltage peaks, which occur when switching off inductive loads and which may cause damage to insulation and contacts, are limited and the contact load reduced.



#### Calculation output voltage

$VDC = VAC \times 0,9$
------------------------

## Contactless release monitoring for ROBA-stop® safety brakes

- **Wear-free**
- **Robust**
- **Magnetic field-resistant**
- **Absolutely reliable**

### Function

Release monitoring prevents unpermitted operating conditions such as for example starting up against a closed brake. *mayr*® power transmission, international leaders in safety brakes for safety-critical applications such as for example passenger elevators or vertical axes, now provides a contactless system with inductive proximity switches for its safety brakes as an alternative to the tried and tested release monitoring system with microswitches.

### Maximum reliability and accuracy

As there are no mechanical parts involved, the lifetime of this new, contactless release monitoring system is not dependent on the switching frequency. The system is **magnetic field** resistant and works **absolutely reliably** and **wear-free**. It is also resistant to impacts and vibrations, as there are no movable parts, and the electronics are completely encapsulated. Other advantages of the inductive proximity switch are the high switching point repetitive accuracy, the low hysteresis and the low temperature drift.

The switching bolt for the inductive proximity switch is installed at the factory and is, in contrast to the release monitoring system with microswitch, not adjustable. Application errors through adjustment of the switching point position can be excluded. This feature, too, plays an important role in maximising functional and operational safety.

### Technical Data

Operating voltage:	10.. 30 VDC
DC rated operating current:	≤ 150 mA
Ambient temperature	-25 to +85 °C
Repetitive accuracy	< 0,015 mm
Hysteresis	< 0,025 mm
Temperature drift (-25 °C to +85 °C)	< +- 0,05 mm

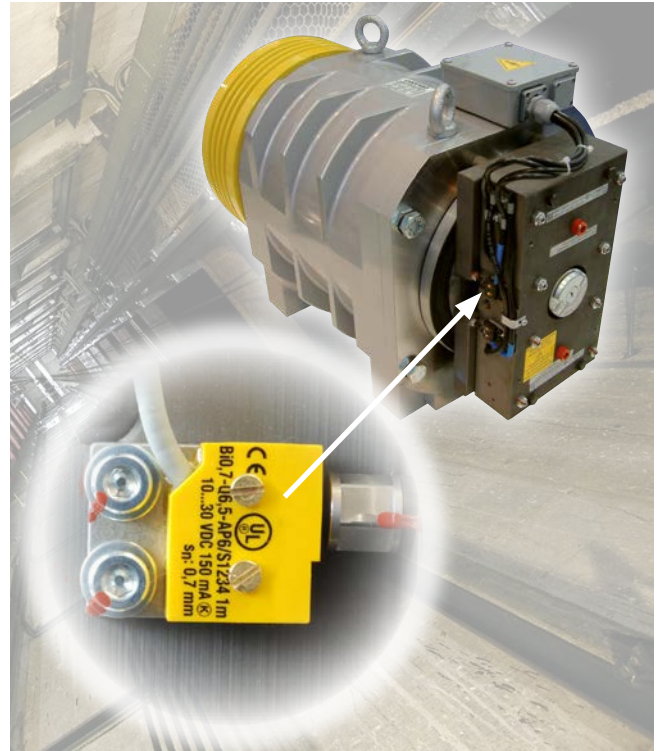

### Optionally NO or NC contacts

The contactless release monitoring system can be designed either as an NO or NC contact. With the NC contact function, the 'High' signal is generated if the brake is switched when de-energised. Here the armature disk drops and the brake closes. Cable breakage is recognised when the brake is closed.

With the NO contact function, the 'High' signal is generated if the brake is energised and the armature disk releases the rotor. The brake is released. Only on generation of the 'High' signal is the motor enabled for start-up. This reliably prevents the motor from starting up against a closed brake. Cable breakage is recognised when the brake is open.

### NO contact function wiring diagram

