

HFE-2

Digital Soft Starters



*Soft Starters and Energy
Optimising Soft Starters*

HFE-2 30 Amp @ 110-230 Volts

APPLICATION

HFE-2 Energy Saving soft starters are designed to control single phase AC motors. Operation is fully automatic, a low starting voltage is applied to the motor as soon as the supply is switched on. The internal automatic ramp control immediately takes over and raises the voltage progressively, causing the motor to accelerate smoothly.

At the end of the ramp period, the motor is operated in Energy Saving mode and the HFE-2 continuously regulates the voltage to match mechanical load.

Energy consumption at light loads is reduced, motor winding and case temperatures are lowered, motor life is extended, noise levels are reduced and power factor is improved.

The LED in the unit indicates when the unit is ENERGY SAVING. As energy consumption is reduced the ENERGY SAVING LED flashes at a slower rate.

The HFE-2 remains in circuit until the supply is disconnected. The HFE-2 automatically resets and is ready for the next start.

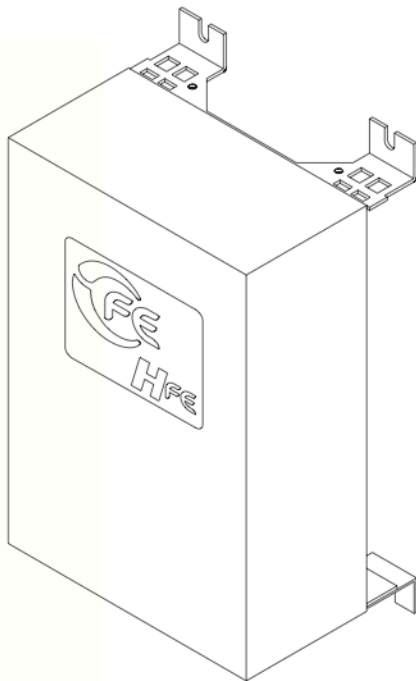

Safety at Work

ISOLATE FROM THE SUPPLY BEFORE WORKING ON THE UNIT OR MOTOR

It is the responsibility of the installer and user to ensure that this equipment is installed, operated and maintained in accordance with the Health and Safety at Work Act in the United Kingdom and all applicable legislation, regulations and codes of practice relevant to your location.

Only qualified personnel should install this equipment, after first reading and understanding this document. The installation instructions must be followed, and any questions or doubt must be referred to the supplier of the equipment.

The system may be configured to allow for auto restart controlled from contacts on the motor side of the unit. Users and operators must always take all necessary precautions to prevent damage to equipment and especially to prevent the risk of injury to personnel working on or near the motor and driven equipment.

The manufacturer does not assume any liability, express or implied, for any consequences resulting from inappropriate, negligent or incorrect installation, application, use or adjustment of the product or circuit design, or from mismatching of a soft starter to a motor.

Mechanical Details HFE-2

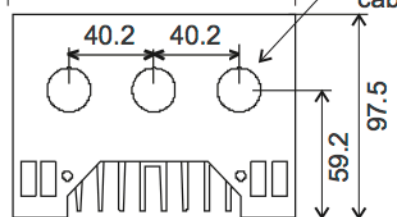
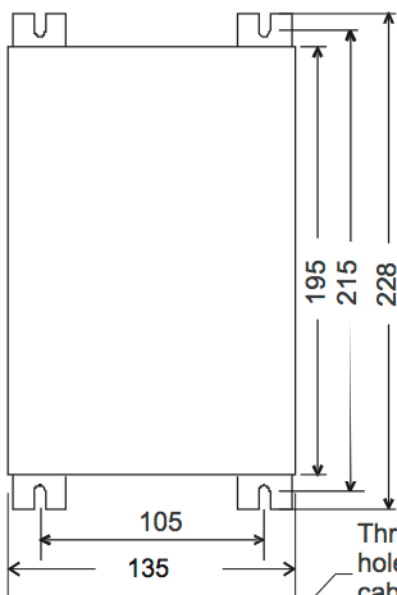

M _L , M _N , N, L1		mm	Nm	lbs-inch	mm
mm ²	AWG				
1.5-25	12 - 4	13	2	18	0.8 x 4

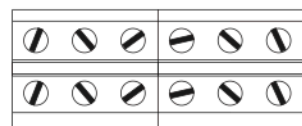

M_L - Supply Live
M_N - Motor Neutral
N - Supply Neutral
L - Motor Live

Earth/Ground
 M5 Screw

MOUNTING

The module must be fixed to a vertical surface. To ensure free air movement a minimum clearance of 40mm must be maintained above and below the unit.

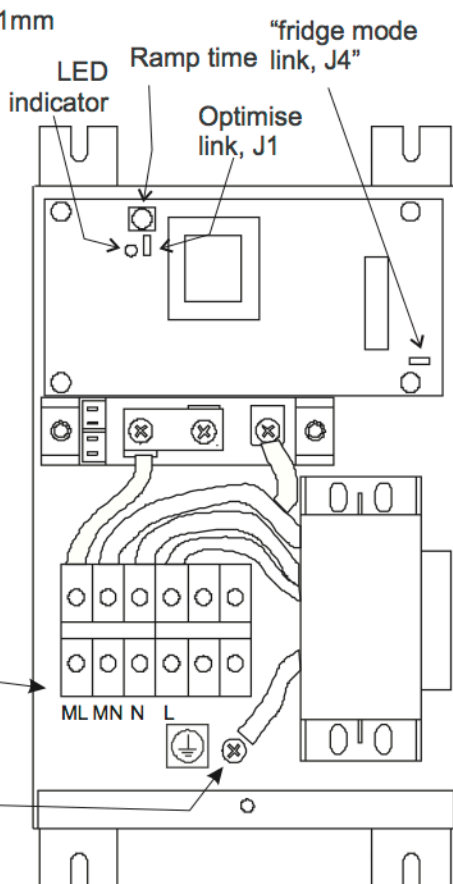

WIRING

The soft starter is normally inserted into the circuit between the motor and whatever switchgear is normally used for isolation or switching. The unit can also be fitted before switchgear so that it can be installed in the supply to equipment which has it's own mechanical control.

This feature allows for easy installation on equipment such as refrigeration where the need to disturb internal wiring is avoided.

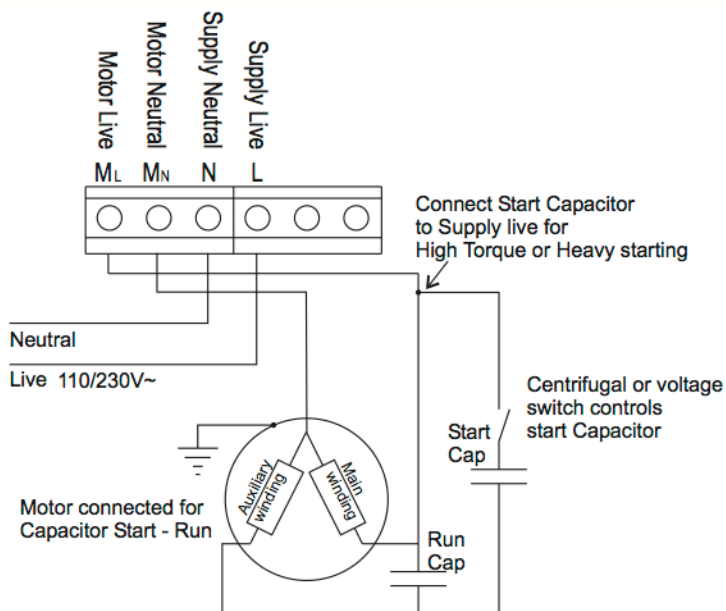

Fig 1.

Typical connection for the HFE-2.

Extra starting torque may be needed for loads which have a particularly 'sticky' starting characteristic. This can be achieved by rearranging the internal connection of the starting capacitor, bringing the connection out and to the supply side of the starter as shown.

The terminations are made with industry standard cage clamp screw terminals mounted on the heatsink.

The incoming power supply is connected to the terminals marked 'L' and 'N'. For EMC compliance it is important that the line circuit is connected to L and the neutral circuit to N. Outgoing connections from the HFE-2 are taken from the terminals marked 'ML' and 'MN' to the motor or load input terminals (see diagram). Ensure that a good connection is made to the earth screw provided.

Fuses or other type of short-circuit protection are required for protection against a cable or motor terminal box fault. These must be fitted externally and on the supply side of the unit. See "Specifications" section for recommended fuse type and cut-out device.

Operation

Set the ramp time potentiometer to midway to approx 2 seconds and start the system. If the motor turns instantly when the soft starter is energised and accelerates satisfactorily then no further adjustment is required. If the rate of acceleration is too great stop the unit and turn the ramp time potentiometer clockwise then restart. Adjust anti-clockwise for a shorter ramp time setting to increase the rate of acceleration. The motor should turn instantly when the soft starter is energised. If not, rearrange the connection of the starting capacitor as shown in fig 1

STARTING

Rating Table

Model	Load Amps (Ie)	Utilisation Category	Start Current (Amps)	Start Time (Secs)	Duty	Up to Starts/Hr
HFE-2	30	AC53a	90	3	99%	60

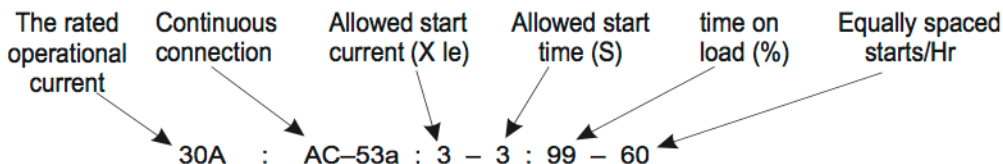

SPECIFICATIONS

Pedestal Voltage	Fixed at ~15%.
Start Time:	Continuously variable from ½S -5S.
Terminations:	Cage clamp terminals suitable for 1.5mm ² (12awg) to 25mm ² (4awg)
Ambient Temperature:	0°C to 40°C without derating.
Enclosure:	IP30 with standard cover:
Rated Operational Voltage:	Ue: 110 to 230V ac (-15% +10%), 50/60Hz
Recommended cut-out device:	32A rated MCB, Trip Characteristic "C", Form 1.
Rated insulation voltage:	Ui: 300V.
Rated impulse withstand voltage:	Uimp: 4kV (1.2/50µs).
Short circuit co-ordination:	Type 1 , Iq: 5kA when protected by recommended Fuse
Fuse Type:	Bussmann 170M3113 or Ferraz 6,6 URD 30 D08A 0125.
Design standards:	IEC 60947-4-2: "AC Semiconductor Motor Controllers and Starters".